



INSULATED CONDUCTOR FITTINGS
CATALOGUE

SCAN QR CODE
TO DOWNLOAD THIS CATALOGUE



INSULATED CONDUCTOR FITTINGS
FOR LOW & HIGH VOLTAGE ABC, CC & CCT
CATALOGUE

SCAN QR CODE
FOR OTHER PLP CATALOGUES



- Communications
- Distribution
- Insulator
- Substation
- Transformer
- Transmission

PREFORMED LINE PRODUCTS

Preformed Line Products Australia Pty Ltd (PLP) has been supplying product to Australian power utilities for over 50 years. Many of the original products are still found in the electricity network today, highlighting the exceptionally high quality standards that are expected and supplied.

The company has three major operating divisions, PLP which manufactures and carries a range of products for the power distribution, power transmission, substation and communications markets. Rack Technologies which has a range of cabinets and enclosures for the data communication, electronics, electrical and security markets and BlueSky Energy which offers solar power products and sustainable energy systems.

PLP's Australian operation boasts in-house manufacturing, engineering, testing, sales and administration. The modern manufacturing facility in the Sydney suburb of Glendenning includes wire forming, forging, casting, plastic moulding and extrusion, sheet metal work, powder coating and assembly. The manufacturing facility is supported by a modern toolroom which includes the latest CNC vertical machining centre, linked directly to the engineering office.

ABC SYSTEMS

PLP manufactures insulated fittings for LVABC, HVABC and CCT to suit aluminium and copper systems for the power distribution sector. Additional to the PLP ABC product range and through a partnership with Michaud Group in France, PLP provides a comprehensive range of insulation piercing connectors (IPC). Michaud's dedication to product quality and technical performance makes them a market leader in the manufacture of IPCs worldwide.

Features of all Michaud IPC are:

- Insulated type suit both aluminium and copper cables – bi-metallic.
- Contacts are compatible with conductor type and application.
- Plastic components are UV stabilised glass reinforced polymer.
- All stainless steel fasteners.
- Torque controlled shear off bolts.
- Connectors are completely air and water tight to prevent corrosion.
- Multiple membrane sealing end caps don't rely on the use of grease.
- Di-electric strength in water over 6kV.
- Fasteners thread is shielded from cable area, to eliminate cable damage whilst tightening.
- Permanently engraved with batch codes and traceability information.
- Conforms to all applicable requirements of AS/NZS4396.

PLP Australia manufactures products that cover the functions of termination, suspension, connection and protection along with a wide range of line hardware fittings and accessories. This Insulated Conductor Fittings Catalogue covers LVABC, HVABC and CCT products and an extensive range of these fittings are stocked at PLP's Glendenning warehouse.

If you have a particular requirement, please do not hesitate to contact PLP on (02) 8805 0000.



CATALOGUE CONTENT

“ *Preformed Line Products, the connection you can count on.* ”

	PAGE
INDEX	
CATALOGUE INDEX	4-6
ALPHABETICAL INDEX	50
PART NUMBER INDEX	51

LOW VOLTAGE FITTINGS

INSULATED PIERCING CONNECTORS	8-9
FLEXIBLE END CAPS	10
HOUSE SERVICE CONNECTOR	11
MAINS CONNECTION BOX (K SERIES)	11
BARE MAINS TO SERVICE CONNECTIONS (R SERIES)	12
PRE-INSULATED COMPRESSION SLEEVES	13
PRE-INSULATED COMPRESSION LUGS	14
MAIN STRAIN CLAMPS	14
SERVICE CLAMPS	15
SUSPENSION CLAMP FOR BUNDLED CONDUCTORS (AS SERIES)	16
SUSPENSION CLAMP	16
SUSPENSION CLAMP FOR BUNDLED CONDUCTORS (ASV SERIES)	17
SUSPENSION CLAMPS AND INTEGRATED STRINGING ROLLER	18
FACADE MOUNTING BRACKETS (CABLE SADDLE)	19
SAFETY SERVICE DISCONNECTOR (SSD)	20
FUSED SWITCH DISCONNECTS (POLE FUSE)	21
ACCESSORIES	21
FUSED SWITCH DISCONNECTS (POLE FUSE)	22
GANG MOUNTED	22
FUSED SWITCH DISCONNECTS	23
IN LINE OVERHEAD OR PILLAR FUSE	23
FUSED SWITCH CONNECTOR (INDEPENDENT TIGHTENING)	24
FUSED SWITCH CONNECTOR	24
PITT FUSED UNDERGROUND (FSD)	25
RING CONNECTOR	25

HIGH VOLTAGE FITTINGS

STRAIN ASSEMBLY AND BUNDLED RESTRAINT	28
HELICAL LINE SPLICE	29
COMPRESSION MIDSPAN JOINT	29
SUSPENSION CLAMP	30
POLE SUPPORT CLAMP	31
YOKE BAR FOR ABC SUSPENSION	31
M16 GALVANISED HOOK BOLTS	32
STRING ROLLER (TYPE LSR23379)	32
POLE BRACKET	33

COVERED CONDUCTOR FITTINGS (CCT)

STRAIN CLAMPS AND COVERS (CCT)	36
UNCOVERED STRAIN CONNECTIONS (CCT)	36
COMPRESSION JOINTS AND COVERS (CCT)	36
NON METALLIC HELICAL TOP AND SIDE TIES (CCT)	37
INSULATOR TOP CLAMPS (CCT)	37
PARALLEL GROOVE CLAMPS FOR LINE TAPS AND NON TENSION JOINTS	38
WORKING EARTH POINT COVERS	38
INSULATION PIERCING CONNECTOR (LIGHTING PROTECTION)	39
MOUNTING BRACKET INSULATORS	39
CABLE STRIPPING TOOLS	40
STRINGING ROLLER ASSEMBLIES	40

HARDWARE

MECHANICAL WEAK LINK	42
EYE NUT	42
HOOK NUT	42
HOOK BRACKET	43
SERVICE SUPPORT BRACKET	43













ASSEMBLY AND STRINGING TOOLS











CABLE STRIPPING TOOLS	46
RUNNING SHEAVES	46
CORE SEPARATING TOOLS	46
RATCHET SPANNERS	47
SWIVELS	47
NYLON (LV CONDUCTORS)	47
COME-ALONGS TENSIONING DEVICES	48
COME-ALONG CLAMP (AS SERIES)	48
CABLE STRIPPING TOOLS	48
HEAVY DUTY STEEL CONSTRUCTION ALUMINIUM AND STEEL BASED CONDUCTORS	49
NYLON (HV CONDUCTORS)	49
J HOOK DRIVER	49

CATALOGUE INDEX



■ LOW VOLTAGE FITTINGS

	Accessories	21
	Bare Mains to Service Connectors (R Series)	12
	Facade Mounting Brackets (Cable saddle)	19
	Flexible End Caps	10
	Fuse Switch Connector	24
	Fuse Switch Connector (Independent Tightening)	24
	Fused Switch Disconnects	23
	Fused Switch Disconnects (Pole Fuse)	21 22
	House Service Connector	11
	In Line Overhead or Pillar Fuse	23
	Insulation Piercing Connectors	8 9
	Main Strain Clamps	14
	Mains Connection Box (K Series)	11







	PITT Fused Underground (FSD)	25
	Pre-Insulated Compression Lugs	14
	Pre-Insulated Compression Sleeves	13
	Ring Connector	25
	Safety Service Disconnect (SSD)	20
	Service Clamps	15
	Suspension Clamp	16
	Suspension Clamp (AS Series) For Aerial-Bundled Conductors	16
	Suspension Clamp (ASV Series) For Aerial-Bundled Conductors	17
	Suspension Clamps and Integrated Stringing Roller	18

■ HIGH VOLTAGE FITTINGS







	Compression Midspan Joint	29
	Helical Line Splice	29





CATALOGUE INDEX







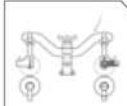

	M16 Galvanised Hook Bolts	32
	Pole Support Clamp	31
	Strain Assembly and Bundle Restraint	28
	String Roller (Type LSR23379)	32
	Suspension Clamp	30
	Yoke Bar for ABC Suspension	31

■ COVERED CONDUCTOR FITTING (CCT)











	Cable Stripping Tools	40
	Compression Joints and Covers (CCT)	36
	Insulator Top Clamps (CCT)	37
	Non Metallic Helical Top and Side Ties (CCT)	37
	Strain Clamps and Covers (CCT)	36
	Uncovered Strain Connections (CCT)	36

	Insulation Piercing Connector (Lightning Protection)	39
	Mounting Bracket Insulators	39
	Parallel Groove Clamps for Line Taps and Non Tension Joints	38
	Stringing Roller Assemblies	40
	Working Earth Point Covers	38

■ HARDWARE

	Eye Nut	42
	Hook Bracket	43
	Hook Nut	42
	Mechanical Weak Link	42
	Pole Bracket	44
	Service Support Bracket	43

■ ASSEMBLY AND STRINGING TOOLS

	Cable Stripping Tools	46 48
	Come-alongs Tensioning Devices	48
	Come-Along Clamp (AS Series)	48
	Core Separating Tools	46
	Heavy Duty Steel Construction Aluminium and Steel Based Conductors	49
	J Hook Driver	49
	Nylon (HV Conductors)	49
	Nylon (LV Conductors)	47
	Ratchet Spanners	47
	Running Sheaves	46
	Swivels	47 49

ABC

LOW VOLTAGE FITTINGS

PAGE

LOW VOLTAGE FITTINGS

INSULATED PIERCING CONNECTORS	8-9
FLEXIBLE END CAPS	10
HOUSE SERVICE CONNECTOR	11
MAINS CONNECTION BOX (K SERIES)	11
BARE MAINS TO SERVICE CONNCETIONS (R SERIES)	12
PRE-INSULATED COMPRESSION SLEEVES	13
PRE-INSULATED COMPRESSION LUGS	14
MAIN STRAIN CLAMPS	14
SERVICE CLAMPS	15
SUSPENSION CLAMP FOR BUNDLED CONDUCTORS (AS SERIES)	16
SUSPENSION CLAMP	16
SUSPENSION CLAMP FOR BUNDLED CONDUCTORS (ASV SERIES)	17
SUSPENSION CLAMPS AND INTEGRATED STRINGING ROLLER	18
FACADE MOUNTING BRACKETS (CABLE SADDLE)	19
SAFETY SERVICE DISCONNECTOR (SSD)	20
FUSED SWITCH DISCONNECTS (POLE FUSE)	21
ACCESSORIES	21
FUSED SWITCH DISCONNECTS (POLE FUSE)	22
GANG MOUNTED	22
FUSED SWITCH DISCONNECTS	23
IN LINE OVERHEAD OR PILLAR FUSE	23
FUSED SWITCH CONNECTOR (INDEPENDENT TIGHTENING)	24
FUSED SWITCH CONNECTOR	24
PITT FUSED UNDERGROUND (FSD)	25
RING CONNECTOR	25

“ Comprehensive Range of Low Voltage ABC Fittings ”



LOW VOLTAGE FITTINGS



INSULATION PIERCING CONNECTORS



Fig. 1

This I.P.C (Insulation Piercing Connector) is used to establish a tap connection from a low voltage ABC (Aerial Bundled Conductors). Aluminium or copper.

Insulated cable to insulated cable (Aluminium or Copper)

Part No.	Fig No.	Cable Range 1 mm ²	Cable Range 2 mm ²	No. of Bolts	Shear Head A/F mm
K440	1	10 - 95	1.5 - 6	1	13
K441	1	25 - 95	6 - 35	1	13
K442	1	35 - 150	1.5 - 25	1	13
K443	1	35 - 150	6 - 35	1	13
K445	1	25 - 95	25 - 95	1	17
K446	2	50 - 150	50 - 150	2	17



Fig. 2

This I.P.C (Insulation Piercing Connector) is used to establish a tap connection from low voltage ABC (Aerial Bundled Conductors) to a low voltage aluminium alloy or copperbare main conductor.

Bare cable to insulated (Aluminium or Copper) cable

Part No.	Fig No.	Bare Cable Material	Bare Cable Size mm ²	Insulated Cable Size mm ²	No. of Bolts	Shear Head A/F mm	Type of Piercing Connection
K470	3	Copper	7 - 95	6 - 35	1	13	Standard
K472	4	Copper	7 - 120	25 - 95	1	17	Standard
K474	5	Copper	50 - 240	35 - 150	2	17	Standard
K471	3	Aluminium	7 - 95	35 - 150	1	13	Standard
K473	4	Aluminium	7 - 120	25 - 95	1	17	Standard
K475	5	Aluminium	35 - 240	50 - 150	2	17	Standard
K235	6	Copper	7 - 95	6 - 35	1	13	Two Stage*
K436	6	Aluminium	7 - 95	6 - 35	1	13	Two Stage*

Installations Notes: 2 bolt IPC connectors must be tightened alternately to apply uniform pressure until shear head is operated. Implementation can be carried out on live-line but without load on the tap conductor.

Important: Two stage IPC's, are able to be installed whilst conductor is under load, up to max of 100A.



Fig. 3

Fig. 4

Fig. 5

Fig. 6

LOW VOLTAGE FITTINGS



INSULATION PIERCING CONNECTORS



K394

Fig. 1

This I.P.C (Insulation Piercing Connector) is used to establish a tap connection of 2 insulated conductors to a low voltage ABC (Aerial Bundled Conductors). When the main conductor connection is preformed by insulation piercing, the connection of the tap is preformed either by insulation piercing.

Insulated cable to multiple insulated cables (Aluminium or Copper)

Part No.	Fig No.	Cable Range 1 mm ²	Cable Range 2 mm ²	No. of Taps	No. of Bolts	Shear Head A/F mm
K394	1	16 - 96	6 - 35	2	1	13
K389	1	35 - 150	6 - 35	2	1	13



K363

Fig. 2

This I.P.C (Insulation Piercing Connector) is used for short-circuiting or earthing of low voltage ABC (Aerial Bundled Conductors) networks. It also enables voltage measurements.

Insulated cables (Aluminium or Copper) - Short circuiting - Test

Part No.	Fig No.	Cable Range 2 mm ²	No. of Bolts	Shear Head A/F mm
K362	1	16 - 25	1	13
K363	2	16 - 70	1	13
K364	2	16 - 150	1	13

LOW VOLTAGE FITTINGS



FLEXIBLE END CAPS

Flexible water and UV resistant end caps to fit the end of ABC conductors.



K01



K02



K03



K247

Flexible End Caps

Part No.	Length mm ²	Cable Entry Diameter mm	Application Range mm ²
K01	32	7	10 - 50
K02	40	10.5	35 - 95
K03	50	13	95 - 150
K247	67.2	31	Round: 50 - 150 Sectoral: 95 - 240

LOW VOLTAGE FITTINGS



HOUSE SERVICE CONNECTOR



The new KBM is a fully overmoulded waterproof connection designed with solid internal chambers. It also includes a new shear cap indicator system. It is used to make electrical connection from an insulated supply cable to an insulated consumer cable.

Features of K96BM are:

- Bi-metal corrosion resistance accepting both copper and aluminium cables.
- Completely overmoulded design.
- Multiple rib sealing system to ensure integrity of seal on all cable sizes - including fully ribbed ABC.
- Central solid barrier dividing each chamber.
- Fully insulated and water proof.
- Overmoulded shearhead bolt.
- Fits the existing main connection box (MCB).
- Consumers cable can be disconnected and reconnected.
- Tested to AS/NZS4396.
- Connectors is marked with cable sizes and strip requirements.
- Consumers and mains sides are clearly differentiated with markings and bolt colour.

Part No.	Supply Cable Range mm ²	Supply Connection Type	Supply Bolt Colour	Customer Cable Range mm ²	Customer Connection Type	Customer Bolt Colour
K96BM	6 - 35	Ins Piercing	Black	4 - 35	Strip Cable	White

MAINS CONNECTION BOX (K SERIES)



These products contain the 'K' Series range of house service connectors and provide an environmentally protective chamber in which to house and mount the connectors. It also provides protection of the consumers mains against UV degradation. The boxes come in single and three phase models with the K96BM.

Features of K Series are:

- IP66D Rated.
- Suits easy entry of consumers mains through the rear of base.

Part No.	Single Phase	Three Phase
K451	Y	N
K455	N	Y
K458*	Y	N
K459*	N	Y

*Note: Empty boxes, no connectors.



LOW VOLTAGE FITTINGS



BARE MAINS TO SERVICE CONNECTORS (R SERIES)



R235

This range of product provides for XPLE or PVC copper or aluminium service cable connection to bare copper and bare aluminium mains in a complete moisture free environment. The service connection is made with insulation piercing technology where there is no need to strip the cable.

Features R Series are:

- Copper connector has forged body for added strength.
- All tested to applicable requirements of AS/NZS4396.
- Both mains and tap bolts incorporate shearhead technology for use with a standard M8 socket.
- Polycarbonate windows employed on all tap facilities to ensure the operator can see the actual connection.
- Connectors can be disconnected and reconnected from the mains with ease.



R235-4

Insulated cable to multiple insulated cables (Aluminium or Copper)

Part No.	Material Type	Bare Mains Range	Area mm ²	O.D. mm	Tap Range mm ²	Pack Qty.
R235	Copper	7/1.00 - 19/3.00	5.5 - 135	3 - 15	6 - 35	10
R235-4	Copper	7/1.00 - 19/3.00	5.5 - 135	3 - 15	6 - 35	10
R236	Aluminium	7/1.75 - 19/3.75	16 - 210	5 - 19	6 - 35	10
R236-4	Aluminium	7/1.75 - 19/3.75	16 - 210	5 - 19	6 - 35	10



R236



R236-4

LOW VOLTAGE FITTINGS



PRE-INSULATED COMPRESSION SLEEVES



K101

Fig. 1



K30

Fig. 2

Pre-Insulated sleeves are used to make an electrical joint, between two aerial bundle insulated conductors. The products are supplied for full tension or non tension applications.

Features of K101 are:

- Totally insulated and water proof.
- Colour coded to applicable cable size.
- Labelled with cable size, die size, strip length, compression locations.
- Permanently engraved with traceability data.

Full Tension Sleeves

Part No.	Fig No.	Cable Size mm ²	Diameter mm ²	Length of Sleeve	Die Part No.	End Cap Colour
K101	1	16	20	104	17.3	Blue
K103	1	25	20	104	17.3	Orange
K106	1	35	20	104	17.3	Red
K110	1	50	20	104	17.3	Yellow
K170	1	95	25	137	21.5	Grey
K185	1	150	25	178	21.5	Violet

Note: Sleeves to connect cables of differing sizes are also available.

Non Tension Sleeves

Part No.	Fig No.	Cable Size 1 mm ²	Cable Size 2 mm ²	Diameter mm	Length of Sleeve	Die Size mm
K30	2	6	6	16	71	14
K31	2	6	10	16	71	14
K32	2	6	16	16	71	14
K33	2	6	25	16	71	14
K35	2	10	10	16	71	14
K36	2	10	16	16	71	14
K37	2	10	25	16	71	14
K39	2	16	16	16	71	14
K40	2	16	25	16	71	14
K53	2	16	35	16	71	14
K42	2	25	25	16	71	14
K54	2	25	35	16	71	14
K55	2	35	35	16	71	14

LOW VOLTAGE FITTINGS



PRE-INSULATED COMPRESSION LUGS



K159

Fig. 1

Pre-Insulated lugs are used to terminate aerial bundle insulated conductors, onto switchgear, busbars or isolators. The products are available in bi-metallic form.

Features of K159 are:

- Totally Insulated and water proof.
- Colour coded to applicable cable size.
- Labelled with cable size, die size, strip length, compression locations.
- Permanently engraved with traceability data.

Bi-Metallic - Aluminium Body - Copper Palm

Part No.	Fig No.	Cable Size mm ²	Diameter mm ²	Length of Sleeve	Palm Size mm	Hole Diameter mm	Die Part No.	Die Size mm	End Cap Colour
K159	1	16	16	73	∅20	10.3	111-140173AL	14.0	Blue
K160	1	25	16	73	∅20	10.3	111-140173AL	14.0	Orange
K163	1	35	20	93	∅25	12.8	111-140173AL	17.3	Red
K164	1	50	20	93	∅25	12.8	111-140173AL	17.3	Yellow
K167	1	95	20	93	∅25	12.8	111-140173AL	17.3	Grey
K158	1	150	25	112	∅30	12.8	111-215AL	21.5	Violet

MAIN STRAIN CLAMPS



IBT25095

Strain clamps are available for both mains and service aerial bundled cables, capable of clamping from 1 to 4 cores. If uneven number of cores are clamped, use filler cables in other locations.

Features of Mains Strain Clamps are:

- Glass reinforced uv stabilised clamping blocks.
- High strength aluminium alloy tensions straps.
- Conforms to requirements of AS3766.
- All hardware is stainless steel - lubricated to eliminate binding.
- Jaws sprung loaded to facilitate easy insertion of cores.

Part No.	Number of Cores	Cable Range mm ²
IBT25095	2	50 - 95
IBT5095	4	50 - 95
IBT95150	4	50 - 150



IBT5095

LOW VOLTAGE FITTINGS



SERVICE CLAMPS



BCST



BCST

BCST Series are a bolted type service strain and suspension clamp.

Features of BCST are:

- Glass reinforced nylon clamping block.
- Blocks are spring loaded for ease of cable insertion.
- Available in galvanised steel or glass reinforced nylon straps.
- Available in open hook or closed eye.
- M10 stainless steel fasteners.
- UV stabilised.

Part No.	Conductor Construction mm ²	Length mm	Standard Pack Quantity
BCST-2025-3G	2 x (10 - 35)	170	50
BCST-2025-3GA	2 x (10 - 35)	170	50
BCST-2025-3P	2 x (10 - 35)	170	50
BCST-2025-3PA	2 x (10 - 35)	170	50
BCST-2025-3GLS	2 x (10 - 35)	250	35
BCST-2025-3GAL	2 x (10 - 35)	250	50
BCST-2025-3GL	2 x (10 - 35)	250	30
BCST-4035-3G	4 x (10 - 35)	170	30
BCST-4035-3GA	4 x (10 - 35)	170	30
BCST-4035-3P	4 x (10 - 35)	170	30
BCST-4035-3PA	4 x (10 - 35)	170	30
BCST-4035-3GLS	4 x (10 - 35)	250	25
BCST-4035-3GAL	4 x (10 - 35)	250	30
BCST-4035-3GL	4 x (10 - 35)	250	20

Note:

- G** = Galvanised Strap
- GA** = Galvanised Strap (closed eye)
- GLS** = Galvanised Latching Strap (long)
- GL** = Galvanised Strap (long)
- GAL** = Galvanised Strap (closed eye) long
- P** = Glass-Filled Nylon Strap
- PA** = Glass-Filled Nylon Strap (closed eye)

SERVICE CLAMPS



IBST435-2

Wedge type strain clamp with sliding jaws. Manufactured from UV stabilised glass reinforced nylon and a stainless steel strap. Designed for 2,3 and 4 core ABC twisted cables.

Features of IBS are:

- Stainless steel ball arm - detachable.
- Conforms to requirements of AS3766.
- Wedge action created by sliding jaws.
- No loose components, jaws attached body.

Part No.	Number of Cores	Range of Cable mm ²	Hook or Eye	Min. Failing Load
IBST435-2	2 up to 4	4 - 35	detachable	2.5kN

LOW VOLTAGE FITTINGS



SUSPENSION CLAMP (ASSERIES) FOR AERIAL- BUNDLED CONDUCTORS



BCSC

The AS series of LV ABC Suspension Clamps are intended for use on straight runs and for line deviation angles up to 25°. These suspension clamps are suitable for coastal environments and are manufactured from high strength corrosion-resistant aluminium alloy, incorporating neoprene bushes and stainless steel hardware. An optional failure link is built into the fitting.

The clamps are designed as a one-piece format, eliminating the problems of dropping components whilst installing the clamp. The AS suspension clamp greatly assists linesmen by supporting the cable in the open position, and allowing fast installation by simply closing the clamp and tightening the fastener.

Features of BCSC are:

- Corrosion resistant cast aluminium body.
- Suitable for coastal and highly polluted environment.
- Neoprene bushes.
- Stainless steel hardware.
- Fast and simple installation.
- Optional failure link feature.
- Tested to Australian Standard 3766.

Part No.	Conductor Construction mm ²	Standard Pack Quantity
BCSC-2050-2S	2 x 50	63
BCSC-2050-2SWL	2 x 50	63
BCSC-2050-2SHD	2 x 50	64
BCSC-2095-2S	2 x 95	63
BCSC-2095-2SWL	2 x 95	63
BCSC-2095-2SHD	2 x 95	64
BCSC-4050-2S	4 x 50	64
BCSC-4050-2SWL	4 x 50	64
BCSC-4050-2SHD	4 x 50	64
BCSC-4095-2S	4 x 95	64
BCSC-4095-2SWL	4 x 95	64
BCSC-4095-2SHD	4 x 95	64

Note:

WL = Weak Link (5kN)

HD = Heavy Duty (stainless wear ring)

SUSPENSION CLAMP



IBSC425

Features of IBSC are:

- EPDM UV stabilised rubber insert.
- Galvanised body - with captive bolt slot.
- Galvanised steel hardware - oversize wing nut.
- Suitable for line deviation up to 30 degrees.
- Conforms to requirements of AS3766.

Part No.	2 Core mm ²	3 Core mm ²	4 Core mm ²
IBSC425			25
IBSC435	50	50	35
IBSC450			50
IBSC470	95		70
IBSC495			95

LOW VOLTAGE FITTINGS



SUSPENSION CLAMP (ASV SERIES) FOR AERIAL- BUNDLED CONDUCTORS



The ASV series of LV ABC Suspension clamps have been developed to protect the integrity of the cable insulation by controlling the cable slip during impact loads. The built-in failure link allows the undamaged cable to drop to the ground, thus providing a coordinated failure mechanism. The clamps are intended for use on straight runs and line deviation angles up to 25°.

The installation features of the clamps have been designed following extensive field trials carried out in conjunction with the major electricity distribution authorities.

The ASV series suspension clamps are suited for coastal environments and are manufactured from high strength corrosion-resistant aluminium alloy and incorporate neoprene bushes and stainless steel hardware. A failure link is built into the clamp.

The clamps are designed as a one-piece format, eliminating the common problem of dropping components whilst installing the clamp. The ASV series Suspension Clamp greatly assist linesmen by supporting the cable in the open position and allowing fast installation by simply closing the clamp and tightening the fastener.

Features of BCSC are:

- Corrosion - resistant cast aluminium alloy body.
- Neoprene bushes.
- Stainless steel hardware.
- Fast and simple installation.
- Built-in failure link for greater system protection.
- Eliminate cable damage during major impacts on the line.
- The PLP AS series suspension clamp complies with Australian Standard 3766.

Part No.	Conductor Construction mm ²	Weak Link Faling Load kN	Standard Pack Quantity
BCSC-4095-3S	4 x 95	6	64
BCSC-4095-3SHD	4 x 95	N/A	30
BCSC-4150-3S	4 x 150	8	30
BCSC-4150-3SHD	4 x 150	N/A	30
BCSC-4150-3H	4 x 150	N/A	30

Note:

HD = Heavy Duty (stainless wear ring)

H = Heavy Duty (no wear ring)

LOW VOLTAGE FITTINGS

SUSPENSION CLAMPS AND INTEGRATED STRINGING ROLLER



IBSRC495

Features of IBSRC are:

- Type IBSRC.
- Cast aluminium body.
- Conforms to requirements of AS3766.
- Integrated stringing roller design.
- UV Stabilised split elastomer bush.
- Controlled release of conductor.

Part No.	2 Core mm ²	3 Core mm ²	4 Core mm ²
IBSRC250	50		
IBSRC450	95		50
IBSRC495			95

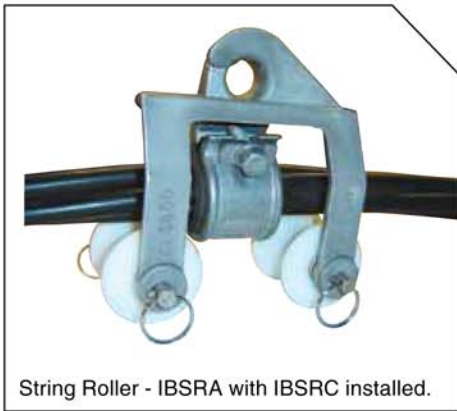

String Roller - IBSRA with IBSRC installed.

Part No.	Description
IBSRA	Auxiliary stringing roller 50 - 95mm ²
BSRA-4150	Auxiliary stringing roller 150mm ²

LOW VOLTAGE FITTINGS



FACADE MOUNTING BRACKETS (CABLE SADDLE)



Features of BRPF are:

- Made from UV stabilised glass reinforced polymer.
- Brackets include 6mm drive nail.
- Cables can be supported on bracket during installation.

Part No.	Drill Size mm	Offset from Structure	Installs Into	Cable Capacity mm
BRPF1	12	10	Masonry	2 x ϕ 25 - 56
BRPF1T	None	10	Timber	2 x ϕ 25 - 56
BRPF6	12	60	Masonry	2 x ϕ 25 - 56



LOW VOLTAGE FITTINGS



SAFETY SERVICE DISCONNECTOR (SSD)



Designed with safety in mind, Preformed Line Products Safety service disconnect ensures controlled disconnection of service under dynamic impact loading. The product severs the conductor after a high impact load, ensuring the span falling to ground is in an un-energised state.

The energised cable remains at the pole attachment point, insulated and well away from the general public. The PLP safety service disconnect can be installed on existing services with no interruption to the consumers power supply.

Part No.	Conductor Size mm ²
SSD-2X25AL19	2 x 25mm AL XLPE



FULLY INSULATED BODY

The PLP SSD™ is manufactured from UV stabilised and fibre reinforced nylon which provides the fitting with complete insulating and mechanically strong features.

ALL COMPONENTS

All components are held captive within the body so there are no loose parts to fall to ground when installing or upon activation.

ONLY ACTIVATES ON IMPACT ABOVE A SPECIFIED LOAD

The PLP SSD™ will only activate if a load is applied of approximately 1.9 kN. The SSD™ will not activate simply due to an increase of tension to the cable such as possum walking along the service. Accurate and reliable failure is guaranteed by the shear pin being specifically sized to the failure load.

CAN BE INSTALLED WITHIN 5 MINUTES

Due to the simple nature of the design of the product, it is easily installed within 5 minutes. Simply place the cable into the clamp and push it into the slots along the body, tighten the nuts on the bolted clamp till secure and bring the bridle around, clip it onto the bollard and snap the cover in place. Installation is now complete! No special equipment is required.

NO NEED TO DISCONNECT CUSTOMER'S SUPPLY

To install the PLP SSD™, there is no need to disconnect the customer's supply because the conductor is not severed to install plugs or sockets. Therefore, the installation of the SSD™ can be done at any time, night or day, without having to advise customers - there is no disruption at all!

NO POSSIBILITY OF SERVICE FAILURE DUE TO POOR CONTACT

There are no active electrical components within the SSD™ (such as contacts) which eliminates the possibility of an electrical breakdown or hot joints.

For application procedures, visit the PLP website.
www.preformed.com.au

LOW VOLTAGE FITTINGS



FUSED SWITCH DISCONNECTS (POLE FUSE)



K490 (K491)

Fused Switch Disconnects is a single-phase device that is installed on a pole or on a wall. It provides electrical protection to an individual customer. It is designed to receive maximum 100A 22 x 58 size fuse cartridge or neutral tube. It is bi-metallic suiting aluminium or copper insulated cables 6-35mm².

Features of K490 (K491) and K291 are:

- Accepts 100A barrel type fuse: 58 x 22mm.
- Pig tail type extraction - type FEHBX.
- UV stabilised body - fully waterproof seals.
- Torque controlled shear head screws.
- Insulation piercing on all cable sizes and types.
- K291 application range: 6 - 95mm² - copper or aluminum.
- K491 application range: 6 - 35mm² - copper or aluminum.
- Facility to be gang mounted.
- Self supported whilst being mounted.
- Cable entry ports designed to eliminate moisture ingress.



K291

Part No.	Description	Standard Pack Quantity
K490	1 Phase FSD 100A G2 + House Number	20
K491	1 Phase FSD 100A G2 (Without House Number)	20
K492	Number Plate for FSD K 491 / Cable	50
K291	Single Phase FSD 100A (Size 22 x 58)	1

ACCESSORIES

K295 - This adaptor is designed to fix the FSD on bracket type "swan neck". It can also be fixed using a stainless steel strap or 2 screw.

FSDSNAB - Mounting Bracket, Glass reinforced UV stabilised mounting bracket for K490 / K491 screw mounting option or swan neck adaptor.

LOW VOLTAGE FITTINGS



FUSED SWITCH DISCONNECTS (POLE FUSE)



K292

Features of K292 are:

- 160A Size 00 din fuse links or 250a solid link.
- Hinged fuse carrier, extraction via hot stick - type LOS3.
- UV stabilised body - fully water proof seals.
- Torque controlled shear head screws.
- Insulation piercing on all cable sizes and types.
- Large application range: 6 - 95mm² - Copper or Aluminum.
- Facility to be gang mounted.
- Self supported whilst being mounted.
- Angled cable entry ports to eliminate moisture ingress.

Part No.	Number of Fittings in Assy	Fuse Rating	Fuse Type	Shear Head A/F mm
K292	N/A	160 / 250	DIN00	13

GANG MOUNTED K292



K292GANG

Triple pole FSD

Gang FSD to suit 160A

Part No.	Number of Fittings in Assy	Fuse Rating	Fuse Type	Shear Head A/F mm
K292GANG	3	160 / 250	DIN00	13
K292GANG4	4	160 / 250	DIN00	13

LOW VOLTAGE FITTINGS



FUSED SWITCH DISCONNECTS



Type - NHP Features

- UV stabilised glass reinforced body.
- Double circlip retention of fuse.
- Comes with integral attachment bracket - pattern B.
- Extraction pigtail tool - type - FEH BX.

Part No.	Cable Range mm ²	Fuse Rating	Fuse Type
NHP100AD	6 - 35	100	HRC 58 x 12
IPSNG		Swan Neck Bracket Pattern B	
COMBHOOK		Combination Bracket Pattern B	
PIGTAIL		Combination Loop Bracket Pattern B	



IN LINE OVERHEAD OR PILLAR FUSE



This sleeve is designed to use a 22 x 58mm AD fuse cartridge or neutral tube. It is used without mechanical load. Mechanical tightening terminals allow implementation in the ABC (Aerial Bundled Conductors) using a simple spanner. Opening and closing of the sleeve can be performed under a load of 63A maximum.

Features of K221 are:

- Connection is established by insulation piercing technology. Tightening is ensured by shear head screw.
- Terminals suit 6 - 35mm² Al/Cu or 16M-50M Al cables.
- Dielectric strength in water is over 6kV.
- Spring holding the fuse cartridge is designed to leave it on the customer side when opening the sleeve (without voltage).
- Seal cap allows to temporary protect access in the network side.
- When the cartridge is implemented, the sleeve the sleeve can be locked by using the sealing ring.

Part No.	Designation	Standard Pack Quantity
K221	Aerial Cutout Sleeve 22 x 58 / 100A	10

LOW VOLTAGE FITTINGS



FUSE SWITCH CONNECTOR (INDEPENDENT TIGHTENING)



K210

Features of K210 are:

- Insulated piercing of the main line and the tap line is independently carried out.
- Tightening efficiency is ensured by shear head screws.
- Dielectric strength in water is over 6kV.
- Spring holding the fuse cartridge is designed to leave it on the customer side when opening the cutout (without voltage).
- When the cartridge is implemented, the cutout can be locked by using the closing ring.
- 100 Amp fuse capacity with 22 x 58mm barrel type fuse.

Type Fuse Switch Connector 100A / 6-35mm²

Part No.	Designation	Main Line mm ²	Tap Line Insulated Al-Cu mm ²	Pack Qty.
K210	Fuse connector piercing	Insulated Al/Cu 35 - 150	6 - 35	10

FUSE SWITCH CONNECTOR



K223

This fuse is designed to use a 10.3 x 38mm size fuse cartridge or neutral tube. It provides electric protection to insulated service or street light conductors connected to a low voltage ABC (Aerial Bundled Conductors). Maximum rating is 20A.

Type Fuse Switch Connector 20A / 1.5 - 16mm²

Part No.	Designation	Main Line mm ²	Tap Line Insulated Al-Cu mm ²	Pack Qty.
K223	Fuse connector piercing 20A / 95 - 10	Insulated Al/Cu 16 - 95	1.5 - 10	10
K224	Fuse connector piercing 20A / 95 - 16	Insulated Al/Cu 16 - 95	6 - 16	10
K228	Fuse connector bare 20A/Cu 95 - 10	Bare Cu 16 - 95	1.5 - 10	10
K229	Fuse connector bare 20A/Al 95-10	Bare Al 16-95	1.5 - 10	10



K224

K228

K229

LOW VOLTAGE FITTINGS



PITT FUSED UNDERGROUND (FSD)



K199

These fully waterproof, insulated connectors are suitable for installation in a pit and enable underground services to be connected quickly and safely by one person using a ratchet spanner. The connectors have been rigorously tested and avoid the need for stripping, compression tooling or heat shrinking.

Features of K199 are:

- Terminals incorporate insulation piercing technology.
- Simple, quick, fail safe three step installation.
- Terminals accept a wide range of cables from 6 - 50mm²
- The K199 terminal has 2 cable entry points to suit phase connections and 100AMP fuse capacity with a 22 x 58 barrel type.
- The tapered flexible cable seal enables the connector to remain waterproof, even when cables are not in straight alignment with the connector.
- Terminals suit XLPE and PVC insulated single core and multi-core cables.
- Reusable - up to three times with copper cable.
- Connector is able to be separated with the fuse remaining in the dead side.
- Plug provided to cap live side after connector is separated.

Part No.	Designation	Range mm ²	Standard Pack Quantity
K199	Fuse Insulation Piercing Pit Connector	6 - 50	10

RING CONNECTOR

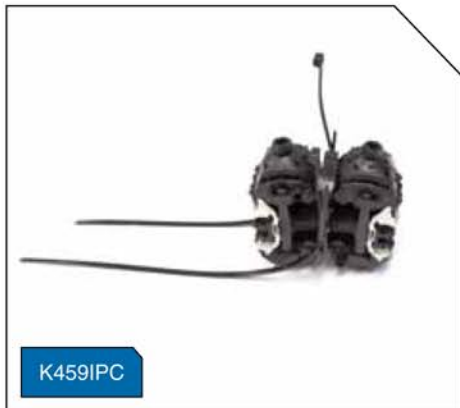

K459IPC

The 4 poles ring connector is used to establish 1 or 2 service tap connections from a low voltage underground network.

Features of K459IPC are:

- Contact is preformed simultaneously with the insulation piercing technology on main and tap sides.
- Earthing device is available as an option
- Connectors is composed of:
 - 2 identical IP2X bipolar tightening parts enabling a non-oriented setting and a symmetric tightening from top.
 - 1 wedge to lock both parts of the connector on the cable.
- Body is made of synthetic materials to ensure safety work under voltage.
- Ergonomics design to meet the particular constraints of the underground work.
- Tightening efficiency is achieved by shear heads screws.
- Underground box and resin kit available on request.

Part No.	Designation	Main Line mm ²	Tap Line Insulated Al-Cu mm ²	Pack Qty.
K459	4 Poles Service Connector (ring connector)	50 - 240	2 x 10 - 50	8

ABC

HIGH VOLTAGE FITTINGS

PAGE

HIGH VOLTAGE FITTINGS

STRAIN ASSEMBLY AND BUNDLED RESTRAINT . . .	28
HELICAL LINE SPLICE	29
COMPRESSION MIDSPAN JOINT	29
SUSPENSION CLAMP	30
POLE SUPPORT CLAMP	31
YOKE BAR FOR ABC SUSPENSION	31
M16 GALVANISED HOOK BOLTS	32
STRING ROLLER (TYPE LSR23379)	32
POLE BRACKET	33

“ Comprehensive Range of High Voltage ABC Fittings ”



HIGH VOLTAGE FITTINGS



STRAIN ASSEMBLY AND BUNDLE RESTRAINT

To secure HVABC conductors at strain or tension points, you must utilise two types of fittings to secure both the catenary, as well as the ABC bundle itself. The Catenary is secured at a strain point using a standard PLP Helical catenary dead-end of applicable size and type - refer table below.

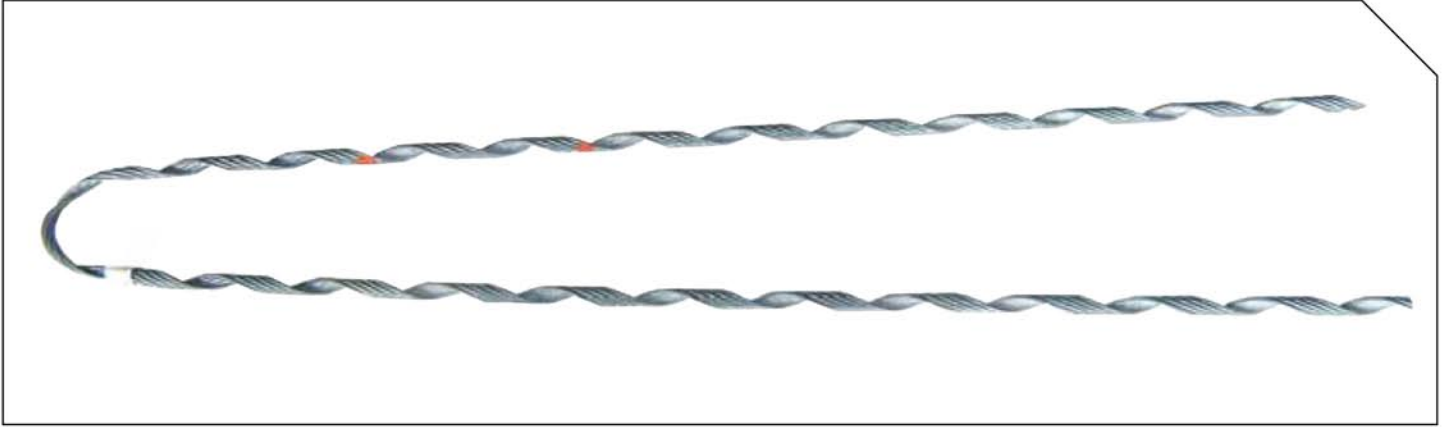

Part No.	HVABC Cable Type AS3599.1 or .2	HVABC Cable Size mm ²	Catenary Stranding	Catenary Material	Colour Code
GFG-060	Metallic Screened	35	7/2.00	Gal Steel	Yellow
GFG-100	Metallic Screened	35 - 185	19/2.00	Gal Steel	Yellow
AFG-136CL	Non Metallic Screened	35 - 95	7/5.00	Alum Alloy	Blue
AFG-175CL	Non Metallic Screened	120 - 185	19/3.65	Alum Alloy	Black

The HVABC bundle assembly, must be secured to the catenary so it does not drift into the middle of the span. This eliminates bird caging, or spreading of the cores. PLP have developed a Helical bundle restraint for this purpose, which is simple to apply and is designed to avoid damage to the phase cores. The assembly is comprised of two Helical dead-ends, which interlock, to tie the catenary to the bundle. The dead-end used to retain the catenary, is designed to be applied over the catenary dead end as above.

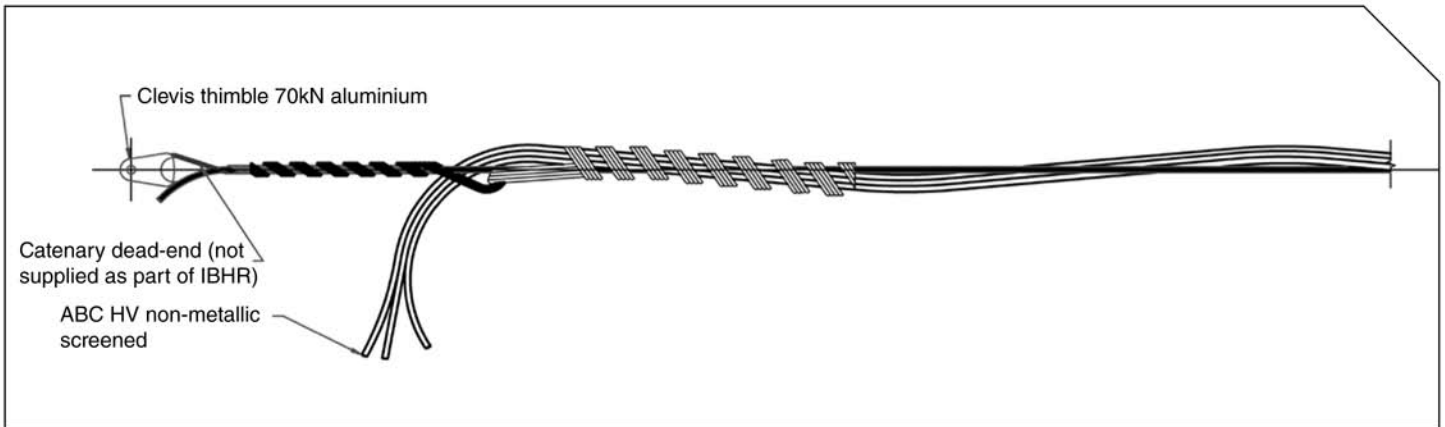

Part No.	HVABC Cable Type AS3599.2	11kV Cable mm ²	22kV Cable mm ²
IBHR1450	Non Metallic Screened	35 - 50	
IBHR1455	Non Metallic Screened	70	35
IBHR1460	Non Metallic Screened	95	50
IBHR1465	Non Metallic Screened	120 - 185	70 - 95
IBHR1765	Non Metallic Screened	120 - 150	
IBHR1770	Non Metallic Screened	185	
IBHR1775	Non Metallic Screened		120 - 150
IBHR1780	Non Metallic Screened		185

HIGH VOLTAGE FITTINGS



HELICAL LINE SPLICE

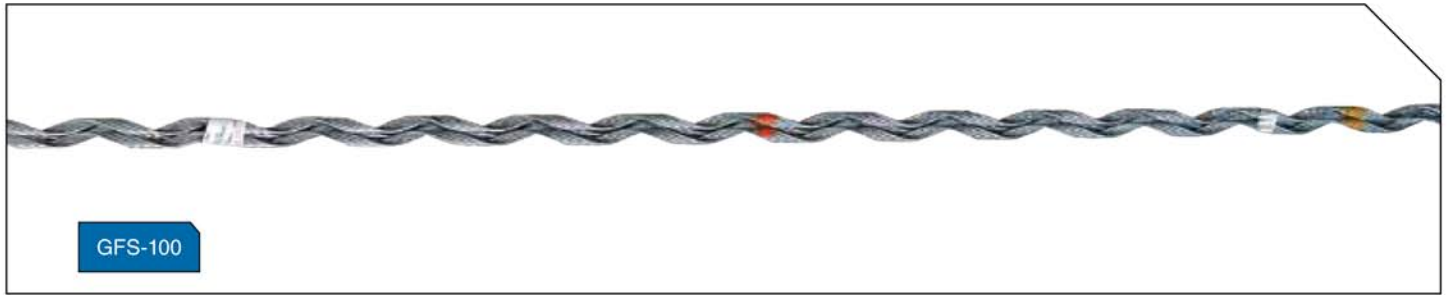

At locations where joints of the catenary on HVABC cables are required, a Helical line splice or a compression midspan joint can be used. For details of Joints for connecting conductor cores, please refer to the cable accessories CD, and the available range of Raychem medium voltage joints and heat shrink sleeving, together with the Utilux catalogue for details of applicable compression connectors.

Part No.	HVABC Cable Type AS3599.1 or .2	Catenary Stranding	Catenary Diameter mm	Catenary Material	11kV mm ² or 22kV
GFS-060	Metallic Screened	7/2.00	6.0	Gal Steel	35
GFS-100	Metallic Screened	19/2.00	10.0	Gal Steel	35 - 185
AFS-143	Non Metallic Screened	7/5.00 Compacted	14.3	Alum Alloy	35 - 95
AFS-175	Non Metallic Screened	19/3.65 Compacted	17.5	Alum Alloy	120 - 185

COMPRESSION MIDSPAN JOINT

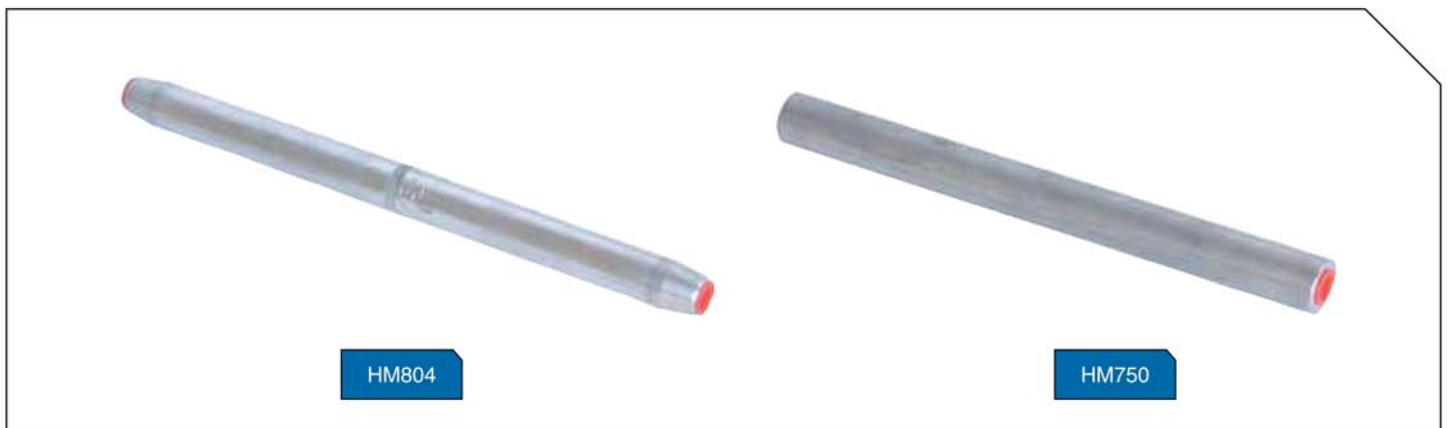

Part No.	HVABC Cable Type AS3599.1 or .2	Catenary Stranding	Catenary Diameter mm	Catenary Material	11kV mm ² or 22kV
HM804	Metallic Screened	7/2.00	6.0	Gal Steel	35
HM808	Metallic Screened	19/2.00	10.0	Gal Steel	35 - 185
HM750	Non Metallic Screened	7/5.00 Compacted	14.3	Alum Alloy	35 - 95
HM751	Non Metallic Screened	19/3.65 Compacted	17.5	Alum Alloy	120 - 185

HIGH VOLTAGE FITTINGS



SUSPENSION CLAMP

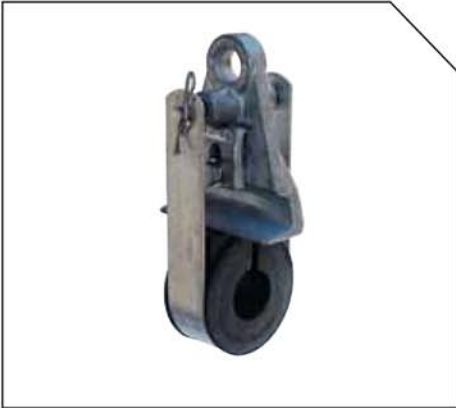

The **HVABC** suspension clamp is suitable for use on metallic and non-metallic screened **HVABC** cables, for voltages up to 22kV. It is designed to accommodate line deviations up to 45 degrees. It can be used at both intermediate suspension locations, as well as a secondary means of securing a bundle to the catenary at strain locations. If used in this manner, an **IBHR** bundle restraint, as per the preceding page, is not required.

Incorporates UV stabilised semi-conductive elastomeric insert, aluminium alloy strap, high strength cast aluminium clamp, and stainless steel hardware. Design of clamps, allows for a minimum of lifting of conductor during installation. Minimum failing load of clamp - 40kN.



Part No.	HVABC Cable Type AS3599.2	Catenary Diameter mm	11kV Cable mm ²	22kV Cable mm ²
IBSH1050	Metallic Screened	6 - 10	35	
IBSH1055	Metallic Screened	6 - 10	50	
IBSH1060	Metallic Screened	6 - 10	70	35
IBSH1065	Metallic Screened	6 - 10	95 - 120	50
IBSH1070	Metallic Screened	6 - 10	150	70 - 95
IBSH1075	Metallic Screened	6 - 10	185	120
IBSH1080	Metallic Screened	6 - 10		150
IBSH1085	Metallic Screened	6 - 10		185
IBSH1840	Non Metallic Screened	14 - 18	35 - 50	
IBSH1845	Non Metallic Screened	14 - 18	70	
IBSH1850	Non Metallic Screened	14 - 18	95 - 120	35 - 50
IBSH1855	Non Metallic Screened	14 - 18	150	70
IBSH1860	Non Metallic Screened	14 - 18	185	95 - 120
IBSH1865	Non Metallic Screened	14 - 18		150
IBSH1870	Non Metallic Screened	14 - 18		185

HIGH VOLTAGE FITTINGS



POLE SUPPORT CLAMP



BCHVPC

Used for supporting HVABC conductor bundle down the pole.

Features of BCHVPC are:

- Stainless M12 fasteners.
- Slot to allow banding to pole or structure.

Part No.	Bundle Diameter mm	Mounting Hole Diameter mm	Standard Pack Quantity
BCHVPC-035-3	35	5.5	35
BCHVPC-040-3	40	5.5	35
BCHVPC-050-3	45 - 50	5.5	35
BCHVPC-050-3A	45 - 50	12	35
BCHVPC-060-3	55 - 60	5.5	35
BCHVPC-060-3A	55 - 60	12	35
BCHVPC-070-3	65 - 70	5.5	35
BCHVPC-070-3A	65 - 70	12	35

YOKE BAR FOR ABC SUSPENSION



YABCOF

This double suspension yoke bar provides up to 60° line deviation by using two suspension clamps of 30° each.

Part No.	Diameter mm	Length - Hook to hook mm	Standard Pack Quantity
YABCOF-150	16	150	25
YABCOF-300	16	300	25
YABCOF-410	20	410	1

HIGH VOLTAGE FITTINGS



M16 GALVANISED HOOK BOLTS



Made of galvanised steel for use with either wood or concrete poles. Straight hook.

Part No.	Length mm	Threaded Length mm	Bolt Size mm
GEB-16150-T	150	150	16
GEB-16250-T	250	250	16
GEB-16350-T	350	350	16
GEB-16450-T	450	450	16

Note: Other lengths available on request.

STRING ROLLER (TYPE LSR23379)

The **LSR23379** stringing roller is a versatile, lightweight and safe product. It is suitable for use on line deviations up to 45 degrees, and accommodates **HVABC** cables up to 185mm² - 22kV.

The deep profile design of the rollers, ensure conductors do not stick or jam during stringing, and the frame design ensures that the conductor is guided and retained at all times. Its wide entry design allows for easy application of suspension clamps, and plenty of working space. Its mounting on support hooks allows for vertical height adjustment, which eliminates the dangerous practice of lifting conductors to secure in suspension clamps. With a weight of just 9kg, it is safe for one person to handle.

The standard assembly is used in conjunction with support hooks and associated brackets at suspension clamp locations, but with the addition of the **Yoke Assembly - LSR23857**, it can also be attached to a hook bolt or bracket at the start of a stringing run, where a suspension point is not required. This allows for the cable to be temporarily supported at termination or strain points, until tensile loads are applied and strain clamps fitted.

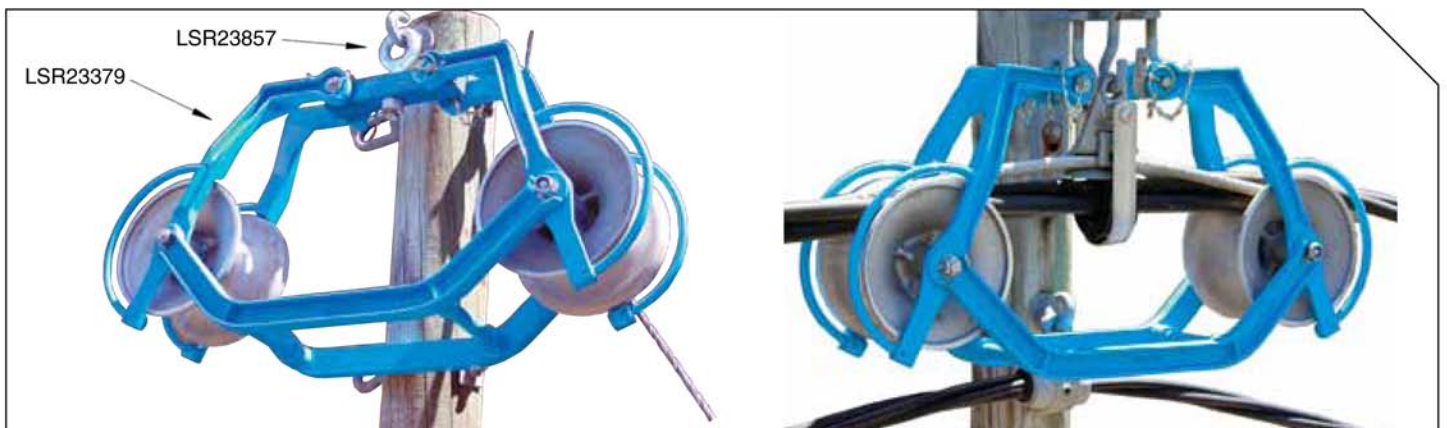

HIGH VOLTAGE FITTINGS



POLE BRACKET



The two most widely used Pole Brackets are - **SB10312** and **IBHPBV**. These items are manufactured from galvanised steel and can be either bolted or strapped to either concrete or timber poles.

Both brackets incorporate a cylindrical mounting tube, complete with 3 hook mounting holes, which are used for two purposes.

- The middle hole is used to locate and mount a suspension clamp.
- The outer two holes (each side) are used to locate and mount a stringer roller assembly - Product No **LSR23379**, and to adjust its height whilst stringing.

Both the suspension clamp and stringer roller are attached to the tube, using support hooks - product No **HB16200**. These hooks are manufactured from galvanised steel, have a minimum failing load of 12kN and are supplied with washers and nuts. The two outer hooks that locate the stringer roller, are used to adjust its mounted height for stringing. This adjustment allows the rollers to be located at a height that eliminates any necessity to lift either the conductor bundle or catenary for attachment into the suspension clamp.

The **SB10312** bracket is generally utilised at a point below the top of the pole, whereas the **IBHPBV** is generally installed at the pole top. The **IBHPBV** bracket has the facility to mount an insulator on its top surface to support a bare conductor during retrofit work, so as customer outages are minimised.

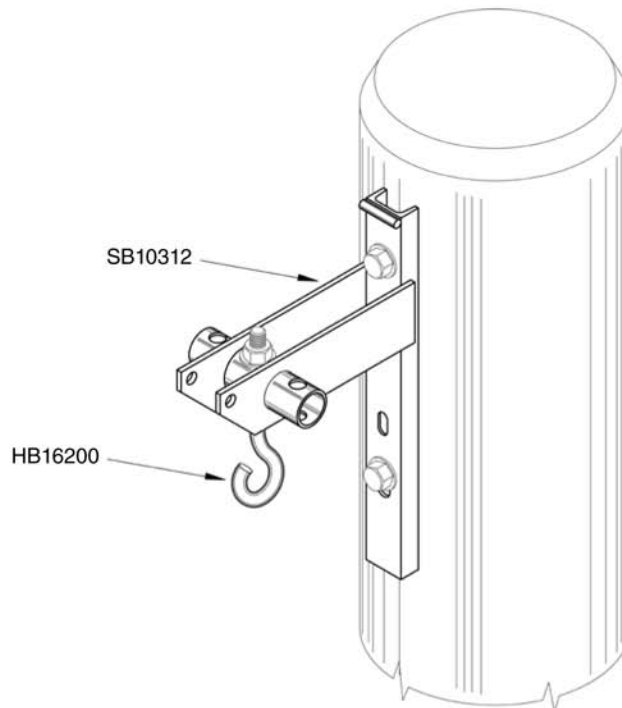

ABC

COVERED CONDUCTOR FITTINGS

PAGE

COVERED CONDUCTOR FITTINGS (CCT)	
STRAIN CLAMPS AND COVERS (CCT)	36
UNCOVERED STRAIN CONNECTIONS (CCT)	36
COMPRESSION JOINTS AND COVERS (CCT)	36
NON METALLIC HELICAL TOP AND SIDE TIES (CCT)	37
INSULATOR TOP CLAMPS (CCT)	37
PARALLEL GROOVE CLAMPS FOR LINE TAPS AND NON TENSION JOINTS	38
WORKING EARTH POINT COVERS	38
INSULATION PIERCING CONNECTOR (LIGHTING PROTECTION)	39
MOUNTING BRACKET INSULATORS	39
CABLE STRIPPING TOOLS	40
STRINGING ROLLER ASSEMBLIES	40

“ Comprehensive Range of CCT
Covered Fittings ”

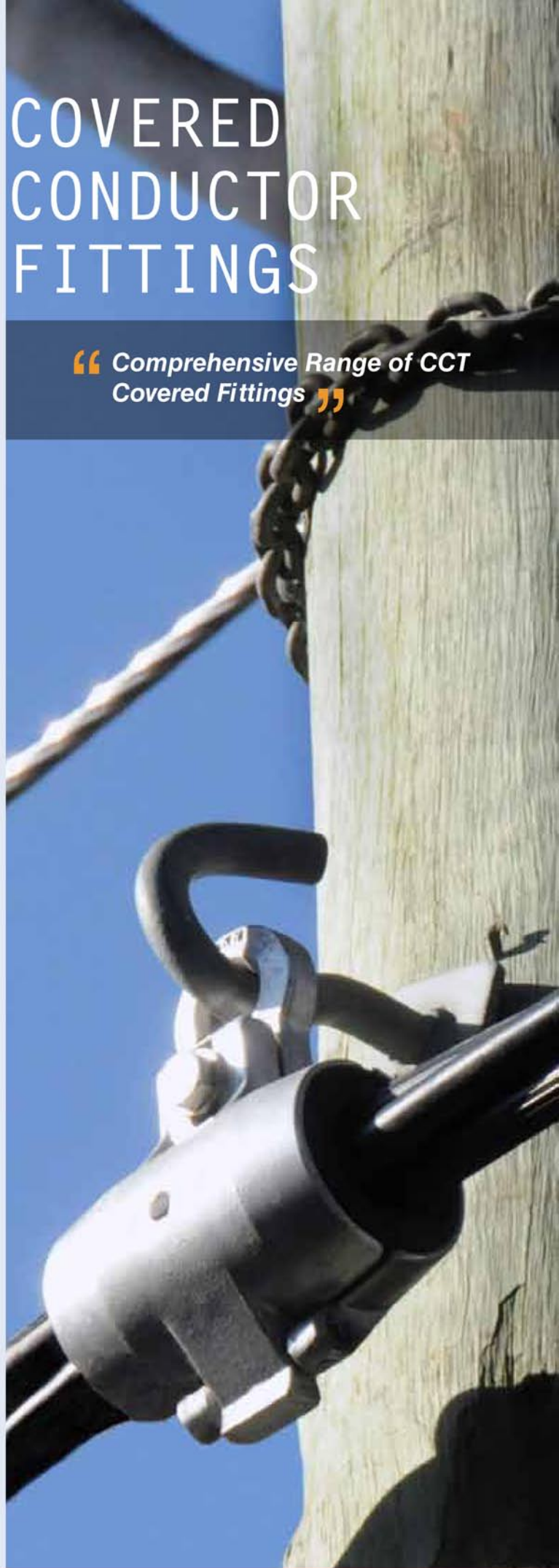

COVERED CONDUCTOR FITTING (CCT)



STRAIN CLAMPS AND COVERS (CCT)



To secure CCT conductors at strain or tension points, the most common method is utilising a rack driven wedge assembly. The clamp incorporates a clevis attachment point, and stringing eye, as well as a clamping bar, to lock the conductor in position once tensioned. The contoured design, eliminates stresses on the conductor as it exits the clamp. The UV Stablised cover, completes the assembly, and the makes the strain assembly fully covered. The cover assembly has been designed for assembly over standard insulators. The assembly is suitable for use on conductors voltages from 11kV up to 33kV.

Part No.	Cover Part No.	Cable Size mm ²	Cable Stranding
CCS80	CCC80120	80	7/3.75
CCS120	CCC80120	120	7/4.75
CCS180M	CCC80120	180	19/3.50

UNCOVERED STRAIN CONNECTIONS (CCT)

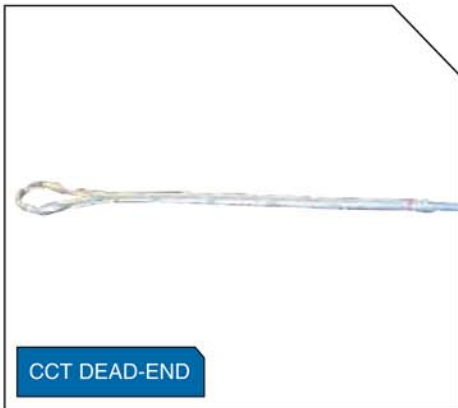

In areas where a fully covered system is not required (for example at termination points where tree proximity is not an issue), an aluminium Helical Dead-end may be used, over the conductor insulation, to eliminate the need for stripping the conductor. This system is utilised on 11kV networks only.

Part No.	Cable Size mm ²	Cable Outer Diameter mm
AFG-188-CL	80	17.9 - 19.4
AFG-210-CL	120	20.9 - 22.4
AFG-238-CL	180	24.1 - 25.7

COMPRESSION JOINTS AND COVERS (CCT)



At locations where CCT conductors must be joined midspan, a series of compression joint kits are available. All kits are supplied complete with Raychem heatshrink mastic lined sleeves, to ensure the joint area is both insulated and sealed. This added sealing slows the onset of corrosion, and decreases resistance in the joint, resulting for otherwise unprotected rapid oxidation of the connection. Compression joints are suitable for all voltages of CCT - 11kV up to 33kV, and are compatible with the material of the conductor.

Part No.	Cable Size mm ²	Cable Stranding
HM704CCT	80	7/3.75
HM704CCT	120	7/4.75
HM718CCT	180	19/3.50

COVERED CONDUCTOR FITTING (CCT)



NON METALLIC HELICAL TOP AND SIDE TIES (CCT)

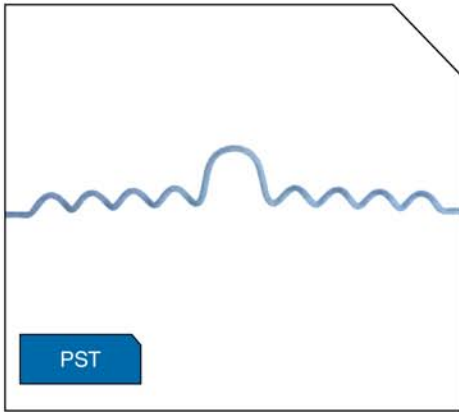

At suspension locations, whether they be at pin or post type insulators, a series of non-metallic Top and Side ties are available. The ties are installed over the insulation of the conductor, and therefore stripping is not required.

Ties are manufactured from UV Stabilised PVC, and are available for 76mm Insulator neck size. Ties may be supplied in a colour to suit the conductor insulation. Standard colour is Grey. Ties are easily applied by hand, as with other Helical ties. Ties are suitable for angular deviations up to 30 degrees.

Part No. (Side Ties Dead-end)	Cable Size mm ²	Cable Outer Diameter mm
PST14307G	80	11
PST18307G	120	11
PST23407G	180	11

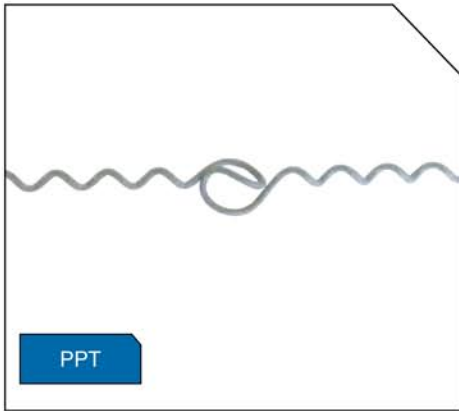

Part No. (Top Tie)	Cable Size mm ²	Cable Outer Diameter mm
PTT14307G	80	17.9 - 19.4
PTT18307G	120	20.9 - 22.4
PTT23407G	180	24.1 - 25.7

INSULATOR TOP CLAMPS (CCT)



At suspension locations where stresses at the connection point, or line angle deviations do not allow for installation of plastic ties, a rigid clamp top can be installed to secure the conductor. The clamps are manufactured from aluminium alloy, and have an application range of 7mm up to 32mm. The clamp can be applied over the conductor insulation. Covers can be provided to protect the clamp from accidental contact.

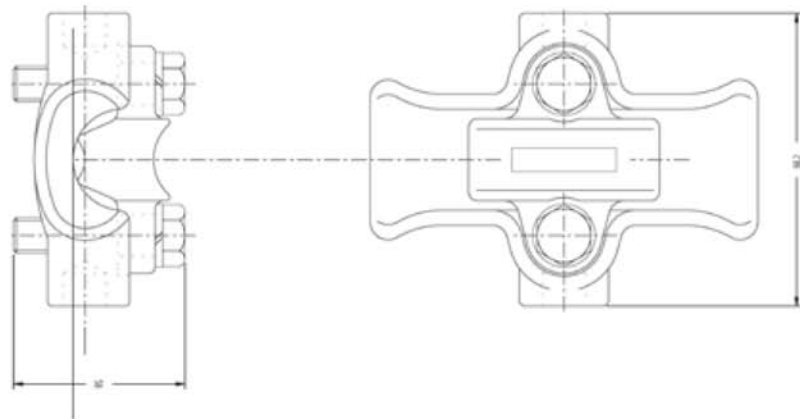

Part No.	Material Type	Minimum Conductor Diameter mm	Maximum Conductor Diameter mm
Y11195	Aluminium	7	32

COVERED CONDUCTOR FITTING (CCT)



PARALLEL GROOVE CLAMPS FOR LINE TAPS AND NON TENSION JOINTS

Parallel Groove clamps can be utilised in non tension applications as conductor joints, as well as line taps to either insulated or bare conductors. Both aluminium and bi-metallic are available, and both items can be covered using an applicable cover. All clamps are supplied complete with oxide inhibitor and belleville spring washers, to control forces generated during electrical heat cycling.



Part No.	Material Type	CCT Cable Size mm ²	Line Tap Cable Size mm ²	Line Tap Cable Size mm	Suitable Cover Part No.
3594-FS	Aluminium	80 up to 180	35 - 240	7.5 - 20.2	CCPGC154
3913-FS	Bi-Metallic	80 up to 180	35 - 185	7.5 - 17.5	CCPGC154
HDGW15	Non Metallic Screened	17.5	Alum/Alloy	810	58

WORKING EARTH POINT COVERS

Working earth point covers are designed to cover a stripped area of conductor which would be used as a local earthing location. The cover is manufactured from UV stabilised material, and is designed such that it can be opened, moved and reapplied using hot sticks. The cover can be easily trimmed to produce a next fit on all sizes of CCT at all voltages.



COVERED CONDUCTOR FITTINGS (CCT)



INSULATION PIERCING CONNECTOR (LIGHTNING PROTECTION)

For applications where Surge Arrestors are used for lightning protection, a connection from the arrester to the conductor can be made using an IPC. This connector **CCIPC11120 (11kV 80 / 120mm²)** utilises shear head bolts, which remain proud of the connector after shearing. An earth lead, with lug, can be attached to this additional length of bolt on the top of the connector. At the bottom of the connector a stirrup - type 25705F01 can also be attached as a means to attach a temporary earth.



MOUNTING BRACKET INSULATORS

Brackets are available to mount insulators in either a trident (3 phases per bracket), or single phase format. All brackets are manufactured from galvanised steel. Brackets are not supplied with pole attachment hardware, due to the variety and type of mounting possibilities.

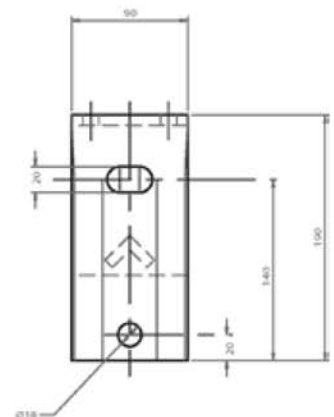
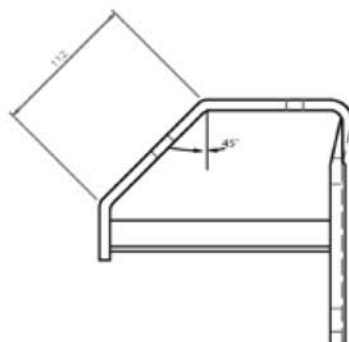
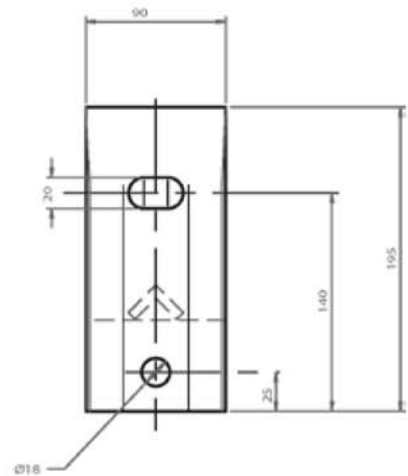
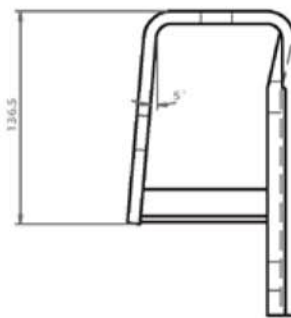

COVERED CONDUCTOR FITTINGS (CCT)



CABLE STRIPPING TOOLS

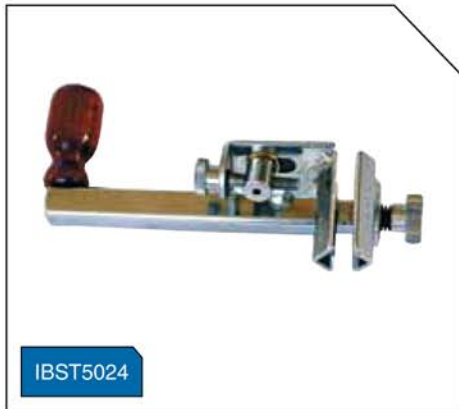

Features of IBST are:

- Used for removal of core insulation.
- Removes insulation up to 5.5mm thick.
- Cable range from 12mm - 32mm.
- Long life blade.

STRINGING ROLLER ASSEMBLIES

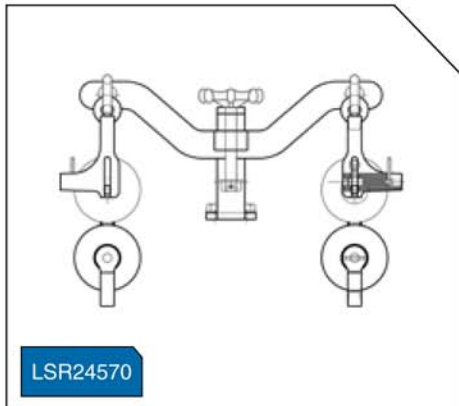

A unique stringing roller assembly has been designed to allow quick, safe and trouble free installation of all sizes of CCT conductors. The assembly has been designed for attachment to the CCB brackets.

Features of LSR24570 are:

- Vertical height adjustment and lowering of cables - no lifting required.
- Movable top roller for easy insertion of conductors.
- Top roller locks in position, so as conductor cannot disengage whilst being strung.
- Lightweight design, able to be installed and removed by one person.
- Durable aluminium rollers with bearings.
- Suitable for stringing angles up to 30 degrees.
- Rollers can also be used to string LVABC up to 150mm².
- LSRUNI is a stringing roller only. It does not include attaching bracket.

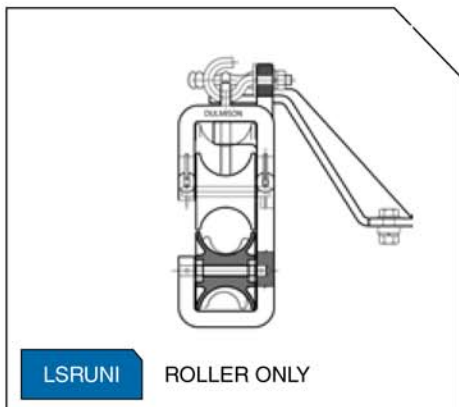

ABC HARDWARE

“ Comprehensive Range of
ABC Hardware ”

	PAGE
HARDWARE	
MECHANICAL WEAK LINK	42
EYE NUT	42
HOOK NUT.....	42
HOOK BRACKET	43
SERVICE SUPPORT BRACKET	43



POLE HARDWARE



MECHANICAL WEAK LINK



Features of IBW are:

- Installed between suspension fitting on pole support fitting.
- Will withstand normal loading, but will fail under impact loads.
- Eliminates damage to suspension fitting and cables.

Part No.	Diameter of Material	Total length	Material Type	Min Failing Load kN
IBWL02	6	81	S/Steel	2
IBWL04	10	100	Gal/Steel	4
IBWL08	12	100	Gal/Steel	8

EYE NUT



Features of ENG are:

- Screwed onto threaded device to produce eye attachment.

Part No.	Thread size	Thread Length	Material Type	Diameter of Eye material
ENG-16	M16	30	Gal/Steel	12
ENG-20	M20	40	Gal/Steel	20
EN2020	M20	40	Gal/Steel	20
ENG-24	M24	45	Gal/Steel	20

HOOK NUT



Features of ENGO are:

- Screwed onto threaded device to produce hook attachment.

Part No.	Thread size	Diameter of Eye material	Material Type	Failing Load kN
ENGO-16	M16	16	Gal/Steel	12
IBHN24	M20	20	Gal/Steel	24

POLE HARDWARE



HOOK BRACKET

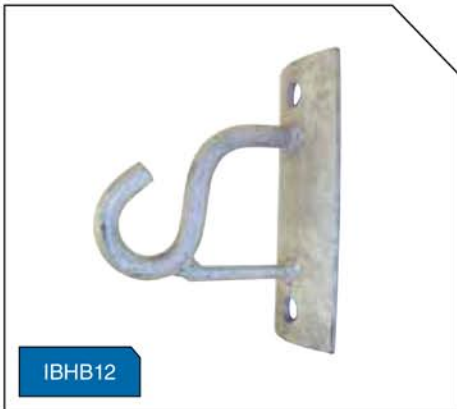

Features of IBHB are:

- Designed for façade mounted strain clamps.
- Can be strapped to concrete poles with stainless steel strap.
- Used as temporary hook, for attachment of stringing rollers.

Part No.	Mounting Centres	Diameter of Eye Material	Material Type	Failing Load kN
IBHB12	150	16	Gal/Steel	12
IBHB24	150	20	Gal/Steel	24

SERVICE SUPPORT BRACKET



Features of IBSSB are:

- Used as a service strain clamp attachment point.
- Used in conjunction with hook bolts hook bolt or hook brackets.
- Galvanised Steel.

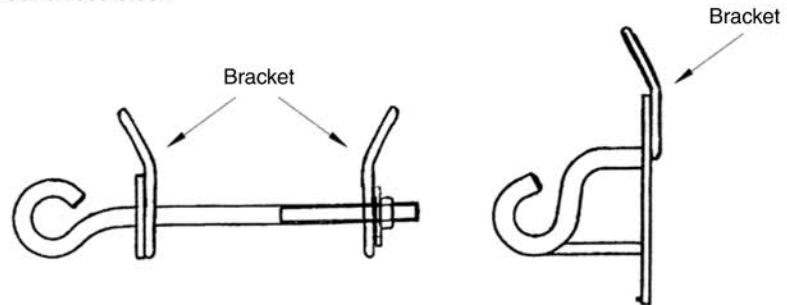

ABC

ASSEMBLY AND STRINGING TOOLS

	PAGE
ASSEMBLY AND STRINGING TOOLS	
CABLE STRIPPING TOOLS	46
RUNNING SHEAVES	46
CORE SEPARATING TOOLS	46
RATCHET SPANNERS	47
SWIVELS	47
NYLON (LV CONDUCTORS)	47
COME-ALONGS TENSIONING DEVICES	48
COME-ALONG CLAMP (AS SERIES)	48
CABLE STRIPPING TOOLS	48
HEAVY DUTY STEEL CONSTRUCTION ALUMINIUM AND STEEL BASED CONDUCTORS	49
NYLON (HV CONDUCTORS)	49
J HOOK DRIVER	49

“ Comprehensive ABC Assembly and Stringing Tools ”



ASSEMBLY AND STRINGING TOOLS



CABLE STRIPPING TOOLS



The IBLST stripping tool, is designed to remove the tough cross linked polyethylene insulation from low voltage aerial cables. The length of insulation removed is able to be controlled to suit stripping for lugs and sleeves.

Part No.	Cable Size mm ²
IBLST50	50
IBLST95	95
IBLST150	150
IBLSTB	Spare blade

RUNNING SHEAVES



Features of 5930 are:

- Attaches to standard hardware, using socket tongue supplied.
- Accommodates cables up to 4 x 150mm².
- Provides clear working space for linesmen.
- Suitable for stringing angles up to 60 degrees - SWL - 10.8kN.
- No lifting of cables required.

CORE SEPARATING TOOLS

Features of IBSW95 are:

- Suitable for LVABC.
- Supplied in pair - on metre of rope.
- Impact resistant material.

Part No.	Cable Size mm ²
IBSW95	up to 150mm ²
K005	up to 150mm ²
K007	80 - 240mm ² (round and sector)



IBSW95

K005

K007

ASSEMBLY AND STRINGING TOOLS



RATCHET SPANNERS



IBLS6

Features of IBLS are:

- Used on all overhead shear bolt connectors.
- 13mm and 17mm across flats in one spanner.
- Reversible ratchet.
- Fits stainless steel nuts used in strain and suspension clamps.
- Fixed socket that cannot be lost or dropped during installation.

Part No.	Size mm ²
IBLS-6	over all length 190mm ²
IBLS-6LONG	over all length 260mm ²

SWIVELS



SWIVEL2

Features of SWIVELS are:

- For use with pulling socks, to eliminate twist.

Part No.	Length mm	Diameter mm	Maximum Cable Diameter mm	Safe Working Load kN
SWIVEL1	122	28.5	10.0	1000
SWIVEL2	178	50.0	18.5	2000

NYLON (LV CONDUCTORS)



CSN

Cable Stockings have many uses in the areas of construction, hauling and pulling. As the type of stocking design varies with each type of cable used, PLP can supply a range of stockings to meet your requirements.

Part No.	Conductor Construction (mm ²)	Tension Rating (kN)	Length Total (mm)
CSN-0225	2 x 25	15	600
CSN-0235	2 x 35	15	600
CSN-0250	2 x 50	15	600
CSN-0295	2 x 95	15	600
CSN-0335	3 x 35	15	600
CSN-0395	3 x 95	25	600
CSN-0425	4 x 25	15	600
CSN-0435	4 x 35	15	600
CSN-0450	4 x 50	15	600
CSN-0470	4 x 70	17	800
CSN-0495	4 x 95	25	800
CSN-4150	4 x 150	25	800

ASSEMBLY AND STRINGING TOOLS



COME-ALONGS TENSIONING DEVICES



EM5095

Features of EM and BCCA are:

- Rugged steel plated construction.
- Cast aluminium clamping jaws.

Part No.	Cable Application Range mm ²	Holding Strength kN	Weight kg
EM35	2 x 25 - 35 & 4 x 16 - 50	5.9	3.2
EM5095	4 x 50 - 95	7.8	5.8
BCCA-495150-3	4 x 95 - 150	9.0	6.5

COME-ALONG CLAMP (AS SERIES)



BCCA

The AS series come-along clamps are manufactured in Australia and are intended for use on LV ABC cables of 4 x 95 and 4 x 150mm² bundles.

Manufactured with aluminium clamping blocks, the AS series come-along clamps are designed to suit the maximum stringing tensions consistent with these cables.

Features of BCCA are:

- Aluminium alloy, clamping block.
- Painted steel frame.
- Galvanised steel shackle.

Part No.	Conductor Size mm ²
BCCA-225495	2 x 25 - 4 x 95
BCCA-495150-3	4 x (95 - 150)

CABLE STRIPPING TOOLS



IBST1342

Features OF IBST1342 are:

Two types of stripping tools are available for use on HVABC cables

- Used for removal of semi conductive screen.
- Cut depth adjustable in 0.1mm increments.
- Spiral scoring function.
- Durable design.

ASSEMBLY AND STRINGING TOOLS



HEAVY DUTY STEEL CONSTRUCTION
ALUMINIUM AND STEEL BASED CONDUCTORS



CSS

Part No.	Conductor Diameter Range mm	Tension Rating kN	Length Total mm
CSS-0407HD	4 - 7mm	5	300
CSS-0611HD	6 - 11mm	8	350
CSS-1014HD	10 - 14mm	15	350
CSS-1419HD	14 - 19mm	20	400
CSS-1928HD	19 - 28mm	37	500
CSS-2840HD	28 - 40mm	54	600
CSS-4055HD	40 - 55mm	62	800

NYLON (HV CONDUCTORS)



CSN

Features of CSN are:

- Mono-filament nylon.
- Double eye.
- Aluminium alloy ferrule.

Part No.	Conductor Construction mm ²	Tension Rating kN	Length Total mm
CSN-0335-HV	3 x 35	25	800
CSN-0350-HV	3 x 50	25	800
CSN-0370-HV	3 x 70	25	800
CSN-0395-HV	3 x 95	31	900
CSN-3120-HV	3 x 120	31	900
CSN-3150-HV	3 x 150	31	900
CSN-3185-HV	3 x 185	31	900

J HOOK DRIVER



TOOL HD-01

Designed with safety in mind, the new PLP J hook driver will make the installation of J hooks into timber poles quicker and easier than ever.

Features of Tool-HD-01 are:

- Spring loaded ball so the hook snaps into place with ease.
- Indication mark, showing the alignment of the hook.
- The conical shape allows the user to safely guide the hook.
- Suits 12mm J & Round eye screw hooks.



Part No.	Description	Range
Tool-HD-01	J Hook Driver	12mm J & Round eye screw hooks

ALPHABETICAL INDEX

Product Description	Pg
Accessories	21
Bare Mains to Service Connectors (R Series)	12
Cable Stripping Tools (CCT)	40
Cable Stripping Tools (IBLST150)	46
Cable Stripping Tools (IBST1342)	48
Come-alongs Tensioning Devices	48
Come-along Clamp (AS Series)	48
Compression Joints and Covers (CCT)	36
Compression Midspan Joint	29
Core Separating Tools	46
Eye Nut	42
Facade Mounting Brackets (Cable Saddle)	19
Flexible End Caps	10
Fuse Switch Connector	24
Fuse Switch Connector (Independent Tightening)	24
Fused Switch Disconnects	23
Fused Switch Disconnects (Pole Fuse)	21
	22
Gang Mounted	22
Heavy Duty Steel Construction Aluminium and Steel Based Conductors	49
Helical Line Splice	29
Hook Bracket	43
Hook Nut	42
House Service Connector	11
In Line Overhead or Pillar Fuse	23
Insulation Piercing Connector (Lightning Protection)	39
Insulation Piercing Connectors	8
	9
Insulator Top Clamps (CCT)	37
J Hook Driver	49
M16 Galvanised Hook Bolts	31
Main Strain Clamps	14
Mains Connection Box (K Series)	11
Mechanical Weak Link	42
Mounting Bracket Insulators	39
Non Metallic Helical Top and Side Ties (CCT)	37
Nylon (HV Conductors)	49
Nylon (LV Conductors)	47
Parallel Groove Clamps for Line Taps and Non Tension Joints	38
Pitt Fused Underground (FSD)	25
Pole Bracket	32
Pole Support Clamp	30
Pre-Insulated Compression Lugs	14
Pre-Insulated Compression Sleeves	13
Ratchet Spanners	47
Ring Connector	25
Running Sheaves	46
Safety Service Disconnecter (SSD)	20
Service Clamps	15
Service Support Bracket	43

Product Description	Pg
Strain Assembly and Bundle Restraint	28
Strain Clamps and Covers (CCT)	36
String Roller (Type LSR23379)	32
Stringing Roller Assemblies	40
Suspension Clamp (AS Series) For Aerial-Bundled Conductors	16
Suspension Clamp (ASV Series) For Aerial-Bundled Conductors	17
Suspension Clamp (HV)	30
Suspension Clamp (LV)	16
Suspension Clamps and Integrated Stringing Roller	18
Swivels	47
Uncovered Strain Connections (CCT)	34
Working Earth Point Covers	38
Yoke Bar for ABC Suspension	31

PART NO. INDEX

Part No.	Pg	Part No.	Pg	Part No.	Pg	Part No.	Pg	Part No.	Pg
3594-FS	38	BCST-4035-3PA	15	GFS-100	29	IBST435-2	15	K39	13
3913-FS	38	BRPF1	19	HB16200	33	IBST5024	40	K42	13
25705F01	39	BRPF1T	19	HDGW15	38	IBSW95	46	K436	8
AFG-136CL	26	BRPF6	19	HM704CCT	36	IBT25095	14	K440	8
AFG-175CL	26	CCB05	39	HM704CCT	36	IBT5095	14	K441	8
AFG-188-CL	36	CCB45	39	HM718CCT	36	IBT95150	14	K442	8
AFG-210-CL	36	CCIPC11120	39	HM750	29	IBWL02	42	K443	8
AFG-238-CL	36	CCS120	36	HM751	29	IBWL04	42	K445	8
AFS-143	29	CCS180M	36	HM804	29	IBWL08	42	K446	8
AFS-175	29	CCS80	36	HM808	29	IPSNG	23	K451	11
BCCA-225495	48	CCWEPC	38	IBHB12	43	K005	46	K455	11
BCCA-495150-3	48	COMBHOOK	23	IBHB24	43	K007	46	K458	11
BCCA-495150-3	48	CSN-0225	47	IBHN24	42	K01	10	K459	11
BCHVPC-035-3	31	CSN-0235	47	IBHR1450	26	K02	10	K459	25
BCHVPC-040-3	31	CSN-0250	47	IBHR1455	26	K03	10	K470	8
BCHVPC-050-3	31	CSN-0295	47	IBHR1460	26	K101	13	K471	8
BCHVPC-050-3A	31	CSN-0335	47	IBHR1465	26	K103	13	K472	8
BCHVPC-060-3	31	CSN-0335-HV	49	IBHR1765	26	K106	13	K473	8
BCHVPC-060-3A	31	CSN-0350-HV	49	IBHR1770	26	K110	13	K474	8
BCHVPC-070-3	31	CSN-0370-HV	49	IBHR1775	26	K158	14	K475	8
BCHVPC-070-3A	31	CSN-0395	47	IBHR1780	26	K159	14	K490	21
BCSC-2050-2S	16	CSN-0395-HV	49	IBLS-6LONG	47	K160	14	K491	21
BCSC-2050-2SHD	16	CSN-0425	47	IBLS-6	47	K163	14	K492	21
BCSC-2050-2SWL	16	CSN-0435	47	IBLST150	46	K164	14	K53	13
BCSC-2095-2S	16	CSN-0450	47	IBLST50	46	K167	14	K54	13
BCSC-2095-2SHD	16	CSN-0470	47	IBLST95	46	K170	13	K55	13
BCSC-2095-2SWL	16	CSN-0495	47	IBLSTB	46	K185	13	K96BM	11
BCSC-4050-2S	16	CSN-3120-HV	49	IBSC425	16	K199	25	LSR23379	32
BCSC-4050-2SHD	16	CSN-3150-HV	49	IBSC435	16	K210	24	LSR24570	40
BCSC-4050-2SWL	16	CSN-3185-HV	49	IBSC450	16	K221	23	LSRUNI	40
BCSC-4095-2S	16	CSN-4150	47	IBSC470	16	K223	24	NHP100AD	23
BCSC-4095-2SHD	16	CSS-0407HD	48	IBSC495	16	K224	24	PIGTAIL	23
BCSC-4095-2SWL	16	CSS-0611HD	48	IBSH1050	29	K228	24	PST14307G	37
BCSC-4095-3S	17	CSS-0611HD	48	IBSH1055	29	K229	24	PST18307G	37
BCSC-4095-3SHD	17	CSS-1014HD	48	IBSH1060	29	K235	8	PST23407G	37
BCSC-4150-3H	17	CSS-1419HD	48	IBSH1065	29	K247	10	PTT14307G	37
BCSC-4150-3S	17	CSS-1928HD	48	IBSH1070	29	K291	21	PTT18307G	37
BCSC-4150-3SHD	17	CSS-2840HD	48	IBSH1075	29	K292	22	PTT23407G	37
BCSRA-4150	18	CSS-4055HD	48	IBSH1080	29	K292GANG	22	R235	12
BCST-2025-3G	15	EM35	48	IBSH1085	29	K292GANG4	22	R235-4	12
BCST-2025-3GA	15	EM5095	48	IBSH1840	29	K30	13	R236	12
BCST-2025-3GAL	15	EN2020	42	IBSH1845	29	K31	13	R236-4	12
BCST-2025-3GL	15	ENG-16	42	IBSH1850	29	K32	13	SB10312	33
BCST-2025-3GLS	15	ENG-20	42	IBSH1855	29	K33	13	SSD-2X25AL19	20
BCST-2025-3P	15	ENG-24	42	IBSH1860	29	K35	13	SWIVELS	47
BCST-2025-3PA	15	ENGO-16	42	IBSH1865	29	K36	13	TOOL-HD-01	49
BCST-4035-3G	15	FSDSNAB	21	IBSH1870	29	K362	9	Y11195	37
BCST-4035-3GA	15	GEB-16150-T	32	IBSRA	18	K363	9	YABCOF-150	31
BCST-4035-3GAL	15	GEB-16250-T	32	IBSRC250	18	K364	9	YABCOF-300	31
BCST-4035-3GL	15	GEB-16350-T	32	IBSRC450	18	K37	13	YABCOF-410	31
BCST-4035-3GLS	15	GEB-16450-T	32	IBSRC495	18	K389	9		
BCST-4035-3P	15	GFS-060	29						

TERMS & CONDITIONS OF SALE

1. APPLICATION

- 1.1. These Terms apply to all goods sold by the Company.
- 1.2. No amendment, alteration, waiver or cancellation of any of these Terms is binding on the Company unless confirmed by the Company in writing.
- 1.3. The Customer acknowledges that no employee or agent of the Company has any right to make any representation, warranty or promise in relation of the Goods or the sale of the Goods other than as contained in these Terms.

2. TERMS OF PAYMENT

- 2.1. Prices are subject to change on thirty (30) days notice.
- 2.2. Payments are to be made direct to the Company, strictly net, without any deduction or discount other than as stated in these Terms or in the relevant invoice or statement.
- 2.3. Payments are to be made within thirty (30) days of the date of the Company's statement or invoice, whichever is the earlier.
- 2.4. Interest is payable on all overdue accounts calculated on a daily basis at the rate of 2% per month as from the due date for payment until payment is received by the Company.
- 2.5. The Company will charge a handling fee of \$100 or such other greater amount for orders of an invoice value under \$1,000 or such higher amount as the Company determines.

3. PROPERTY IN GOODS

Legal and beneficial ownership of Goods supplied by the Company will not pass to the Customer until such time as the Goods so supplied have been paid in full in cash or cleared funds.

4. RE-SALE OF GOODS

- 4.1. If the Customer is a re-seller then, subject to sub-clause 4.2.4, the Customer has the right to sell the Goods in its own name at full market value and in the ordinary course of business.
- 4.2. Until the amount payable to the Company in respect of the Goods has been paid in full in cash or cleared fund:
 - 4.2.1. the Customer will hold the Goods only as bailee for the Company;
 - 4.2.2. the Goods must be stored in such manner that they are readily distinguishable from other goods owned by the Customer or other persons and so as to clearly show that they are the property of the Company;
 - 4.2.3. the Customer must indemnify the Company from and against any Claim incurred or suffered by the Company arising out of the possession, use or disposal of the Goods by the Customer or repossession or attempted repossession of them by the Company; and
 - 4.2.4. any sale of the Goods under clause 4.1 will only be effected by the Customer as trustee for the Company and the proceeds of such sale and the rights of the Company's Customer against its customer arising from such sale will be held on trust for the Company. The said proceeds must be held in a separate account or otherwise clearly identified in the books and records of the Customer.
- 4.3. The Customer must ensure that the Goods are stored in accordance with any reasonable direction or instructions from the Company and, without the prior written consent of the Company, must not treat, alter, or incorporate the Goods into or with another product of the Company or any third party, or otherwise vary the Goods as supplied by the Company.

- 4.4. If the Customer resells any Goods then, unless the Goods are clearly identifiable by serial numbers or other distinguishing marks, the Customer is deemed to have disposed of the Goods in the chronological order of supply by the Company to the Customer (oldest to most recent).
- 4.5. On the resale of the Goods by the Customer, the Customer must ensure that any contract between the Customer and its customer limits or excludes any liability of the Company to such customer on no less favourable terms than the Company's liability to the Customer under clause 19 or on more limiting terms.
- 4.6. Despite clause 4.5, the Customer must indemnify the Company from and against any Claim incurred or suffered by the Company arising out of the resale of the Goods by the Customer.

5. INCORPORATION OF GOODS

- 5.1. If the Customer uses the Goods in some manufacturing or construction process of its own or on behalf of some third party and receives monies from time to time in respect of such use then the Customer must hold a portion of such monies received, calculated in accordance with clause 5.2, in trust for the Company.
- 5.2. The portion referred to in clause 5.1 will be so much of the monies received as equals the amount owing by the Customer to the Company at the time of the receipt of such monies by the Customer.
- 5.3. Money received by the Customer excludes any debts due to other parties by the customer but not yet paid by the Customer.
- 5.4. In the circumstances outlined in clause 5.1, the Customer must not assign or deal with its debts in any way prior to payment of the moneys receivable by the Customer in respect of the Goods as their use as described in clause 5.1 prior to their payment to the Company.

6. INSTALLATION OF GOODS

- 6.1. All Goods must be handled, mounted and installed:
 - 6.1.1. by an appropriately licensed technician/tradesman; and
 - 6.1.2. in accordance with:
 - 6.1.2.1. the manufacturer's directions, if any;
 - 6.1.2.2. the relevant Application Procedure found at http://www.phhttp://www.preformed.com/index.php?option=com_phocadownload&view=category&id=29&Itemid=194refor med.com/index.php?option=com_phocadownload&view=category&id=29&Itemid=194;
and/or
 - 6.1.2.3. the applicable industry standard, as the case may be.
- 6.2. If any Goods are not handled, mounted or installed in accordance with clause 6.1 then, subject to any statutory provision or other general law obligation to the contrary, the Company will not be liable for any defect or fault in the Goods or for any loss or damage to the Customer caused by the Goods.

7. DEFAULT

- If:**
- 7.1. the Goods are not paid for in accordance with these Terms or any other written agreement between the Company and the Customer;
 - 7.2. the Company receives notice of, or reasonably believes that a third party may attempt to levy execution against or attach the Goods; or
 - 7.3. any other event occurs which in the Company's opinion is likely to adversely affect the Customer's ability to pay for the Goods (including but not limited to the appointment of Insolvency Representative to the Customer's undertaking),

then the Company may at any time thereafter, without notice to the Customer and without prejudice to any other rights which it may have against the Customer, terminate any Contract relating to the Goods and the bailment referred to in clause 4.2.1.

8. RIGHT TO ENTER PREMISES

In any of the circumstances referred to in clause 7, the Customer:

- 8.1. authorises the Company by itself, its agents or representatives at all reasonable times, without notice, to enter onto (with force if reasonably necessary) and at all necessary time(s), to remain in and on any premises where the Goods are located in order to collect the Goods, without being guilty of any manner of trespass; and
- 8.2. assigns to the Company all the Customer's rights to enter onto and remain in and on such premises until all the Goods have been collected.

9. ADMINISTRATION & RECEIVERSHIP

In any of the circumstances referred to in clause 7.3:

- 9.1. neither the Customer nor its Insolvency Representative or any other person acting for the Customer and/or its creditors is entitled to sell, charge, remove, dispose of, use or otherwise deal with the Goods in any way inconsistent with the Company's ownership of the Goods, without the Company's prior written approval;
- 9.2. the Customer, its Insolvency Representative and every other person acting for or on behalf of the Customer and/or its creditors is obliged to re-deliver the Goods to the Company immediately or immediately on his appointment, as the case may be, at its or his expense; and
- 9.3. if the Goods are returned to or collected by the Company, the Company will within twenty-eight (28) days, account to the Customer or its Insolvency Representative for all monies received for the Goods from the Customer less the Company's reasonable administration charges, expenses incurred and loss of profits involved.

10. CUSTOMER AS TRUSTEE

If the Customer carries on business as trustee of a trust then the Customer warrants that:

- 10.1. the Customer enters into a Contract or Contracts to purchase the Goods as trustee of a trust;
- 10.2. the Customer has all requisite powers to enter into a Contract under these Terms;
- 10.3. the beneficiary of the trust approves the purchase of the Goods on the terms of the Contract; and
- 10.4. the assets of the trust are available to the Company in satisfaction of any debt incurred by the Customer for the purchase of the Goods.

11. GOODS AND SERVICES TAX

- 11.1. GST is not included in the quoted price.
- 11.2. If GST is imposed on the Company in respect of the Goods then the Customer must pay the amount of such GST to the Company in addition to the quoted price.
- 11.3. The Company must give the Customer written notice of the amount of any GST payable under this clause and provide a tax invoice showing the amount of GST payable.

12. CUSTOMS DUTIES, TARIFFS AND LEVIES

All applicable customs duties, tariffs and levies are payable by the Customer unless the order, order confirmation, invoice or other writing indicates otherwise.

13. DELIVERY

- 13.1. Availability dates are estimates only, but the Company will use its best endeavours to maintain these estimates.
- 13.2. If the place of delivery to or collection of the Goods by the Customer is within Australia then the Company will, at the Customer's request, arrange for the delivery of the Goods at the Company's expense.

14. DELIVERY BY INSTALMENTS

- 14.1. The Company reserves the right to deliver the Goods in whole or by instalments as well as to deliver prior to the date for delivery and in any such event the Customer must not refuse to take delivery of the Goods.
- 14.2. Where the Goods are delivered by instalments, each instalment is sold under a separate Contract.
- 14.3. Any failure on the part of the Company to deliver instalments within any specified time does not entitle the Customer to repudiate the Contract with regard to the balance of the Goods remaining undelivered.

15. RISK

- 15.1. The Goods are entirely at the risk of the Customer from the moment the Goods leave the Company's premises or physical custody.
- 15.2. The Customer must at its own expense, maintain the Goods and insure them for the benefit of the Company for their full replacement value against theft, destructions, fire, water and other risks, as from the moment of delivery to or collection by the Customer until property of and title to the Goods have passed to the Customer.
- 15.3. The Customer must take all reasonable measures to ensure that the Company's title to the Goods is in no way prejudiced. If any of the Goods are lost, destroyed or damaged, any insurance proceeds relating to the Goods in respect of such event that are received by the Customer are held on trust for the Company and must be paid to the Company immediately on receipt but only up to the amount that the Customer owes the Company in respect of those Goods.

16. INSPECTION

Unless the Customer has inspected the Goods and given written notice to the Company within seven (7) days after collection or delivery that the Goods do not comply with the relevant specifications or descriptions, the Goods are deemed to have been accepted in good order and condition.

17. RETURN OF GOODS

- 17.1. No returns will be accepted unless the Company has previously agreed in writing. If the Company agrees to the return of Goods, they must be unsoiled, undamaged and in a resaleable condition (or Customer pays for all costs of replacement or repair) and delivered at the Customer's expense to the Company's premises unless otherwise agreed by the Company in writing.
- 17.2. Goods imported especially for the Customer or non-standard equipment made to special order cannot under any circumstances be returned and/or credited.

18. CANCELLATION OF ORDER

No order may be cancelled, modified or deferred without the prior written consent of the Company (which is at the Company's sole discretion) and if consent is given, then such consent will, at the Company's election, be subject to the Company being reimbursed all losses, including loss of profits, and paid a cancellation and restocking fee (being not less than 10% of the invoice value of the Goods).

19. COMPANY'S LIABILITY LIMITED

- 19.1. The Customer acknowledges and agrees that:
 - 19.1.1. the Customer has determined that the Goods are fit for the purpose for which the Customer requires them;
 - 19.1.2. the Customer has the right to inspect the Goods in accordance with clause 19 to satisfy itself that the Goods are fit for purpose and/or are of merchantable and acceptable quality;
 - 19.1.3. the Customer has not relied on the Company's skill and judgment in selecting the Goods; and
 - 19.1.4. the Company is not responsible if the Goods do not comply with any applicable safety standard(s) or similar regulation(s), and that the Company is not liable for any Claim resulting from such non-compliance.
- 19.2. The Company is not subject to, and the Customer releases the Company from any liability (including but not limited to Consequential Loss or Damage, removal costs or re-installation costs or liability for loss of use or profit) arising from any delay in delivery or defect or fault in the Goods or any negligence by the Company in relation to the Goods (including but not limited to their manufacture), to the full extent permitted by law.
- 19.3. If, despite clause 19.2, the statutory provisions under the *Competition and Consumer Act 2010* (Cth), the *Sale of Goods Act 1923* (NSW) or any other act or the general law impose on the Company a liability for a defect or fault in the Goods then, to the extent to which the Company is entitled to do so, the Company's liability under the statutory provisions is limited, at the Company's option, to:
 - 19.3.1. replacement or repair of the Goods;
 - 19.3.2. supply of equivalent Goods; or
 - 19.3.3. payment of the cost of replacing or repairing the Goods or of acquiring equivalent Goods,and in any case:
 - 19.3.4. the Company will not be liable for any Consequential Loss or Damage or any other loss or damage; and
 - 19.3.5. the Company's total liability to the Customer is limited to the invoice value of the Goods.

20. WARRANTIES AND WARRANTY CLAIMS

- 20.1. The Company warrants that the Goods are free of substantive defects.
- 20.2. The Company also warrants to the Customer that the Goods will be supplied in an undamaged condition.
- 20.3. Except for any guarantees imposed by the *Competition and Consumer Act 2010* (Cth) and the warranties stated in clauses 20.1 and 20.2, the provision of any other act or law implying terms, conditions, guarantees and/or warranties which might otherwise apply to or arise out of the Contract are hereby expressly negated and excluded to the full extent permitted by law.
- 20.4. On discovery of any defect in the Goods, the Customer must notify the Company in writing of such defect.
- 20.5. All warranty claims must be received by the Company within thirty (30) days of the day of delivery. This warranty extends only to the Customer and to no other person.
- 20.6. The Customer's failure to provide written notice to the Company within the required time of any alleged breach of the above warranty will release and discharge the Company from any obligation or liability for that breach of warranty.
- 20.7. The Customer must not carry out any remedial work to allegedly defective Goods without first obtaining the written consent of the Company to do so

otherwise all of the Company's warranties will be voided to the full extent permitted by law.

- 20.8. The warranties stated in clauses 20.1 and 20.2 do not apply in circumstances where the Customer treats, alters, incorporates the Goods into or with another product of the Company or any third party, or otherwise varies the Goods as supplied by the Company.

21. CATALOGUES

Particulars in leaflets, catalogues, drawings, brochures and other printed material are illustrations only, form no part of the Contract between the Company and the Customer, and are not binding on the Company.

22. CUSTOMER'S PROPERTY

- 22.1. All Customer's property in or under the Company's custody or control will be entirely at the Customer's risk in regard to loss or damage from any cause whatsoever.
- 22.2. The Company will have a first and paramount lien upon all Customer's property (including but not limited to dies provided by or manufactured for the Customer) which is in the Company's possession or control until all accounts due to the Company by the Customer are paid in full.
- 22.3. The Company may sell any of the Customer's property on which the Company has a lien if:
- 22.3.1. a sum in respect of which the lien exists is presently payable;
- 22.3.2. the Company has, not less than fourteen (14) days before the date of the sale, given the Customer a written notice setting out, and demanding payment of such part of the sum in respect of which the lien exists as is presently payable; and
- the Customer has failed to pay the sum referred to in the notice.
- 22.4. The proceeds of the sale will be applied by the Company:
- 22.4.1. firstly to cover the costs of the sale;
- 22.4.2. secondly in payment of such part of the sum in respect of which the lien exists as is presently payable; and
- 22.4.3. by way of accounting to the Customer.

23. TOOLING

- 23.1. If the Company agrees to supply Tooling to the Customer then the Tooling remains the property of the Company and despite the fact that the Customer may have borne or contributed to the cost of the development and manufacture of the Tooling.
- 23.2. The Company reserves the right to recall the Tooling from the Customer at any time.

24. PERSONAL PROPERTY SECURITY

- 24.1. The Customer acknowledges that if the Company has a security interest in:
- 24.1.1. the Goods;
- 24.1.2. the proceeds of the Goods;
- 24.1.3. the Customer's property referred to in clause 22.1; and/or
- 24.1.4. the Tooling,
- for the purposes of the PPSA then the Company may register its security interest in the Goods, proceeds, Customer's property and/or Tooling, as the case may be, on the PPSR.
- 24.2. The Customer undertakes, at its own expense, to promptly do anything (such as supplying information) which the Company requests and reasonably requires the Customer to do for the purposes of ensuring that the security interest is enforceable, perfected or otherwise effective.

- 24.3. The Customer acknowledges that if the Company has a security interest in the Goods, proceeds, Customer's property and/or Tooling, as the case may be, then the Company may register its security interest on the PPSR and the Customer, in accordance with section 157(3)(b) of the PPSA, waives the right to receive notification of the registration.

25. COPYRIGHT

- 25.1. The Customer warrants that:
- 25.1.1. the drawing of any extruded shape submitted by the Customer; and
 - 25.1.2. any Tooling made in accordance with such drawing; and
 - 25.1.3. any article of extruded design made from such Tooling, does not infringe the rights of any third party (whether copyright, registered design pattern, trademark, confidential information or otherwise) or breach any applicable law.
- 25.2. In the event of any Claim or order for costs (including legal expenses on a solicitor and client basis) referable to the rights and/or laws referred to in clause 25.1 being made or brought against the Company, the Customer must fully indemnify the Company and keep the Company indemnified from and against same.

26. SAMPLES

Any sample inspected by the Customer is solely for the Customer's convenience and does not constitute a sale by sample. All samples remain the property of the Company.

27. SPECIFICATIONS

- 27.1. Unless otherwise agreed in writing, the Goods are supplied subject to any specification as to weight, quantity, size, dimensions, finishes, chemical composition and physical properties as may be published generally by the Company or as may be set out in any specification issued by the Company in relation to the Goods or, if no such specification has been published or set out, subject to such specification as is normally regarded as being commercially acceptable.
- 27.2. Where any specification for the Goods are to be supplied by the Customer, they must be supplied in a reasonable time to enable the Company to complete delivery by the date for delivery.

28. CONTRACT

- 28.1. The terms of the Contract between the parties are wholly contained in these Terms and any other writing signed by both parties.
- 28.2. The Contract under these Terms is deemed to have been made at the Company's place of business in Sydney, New South Wales and any cause of action is deemed to have arisen there.
- 28.3. The Contract is governed by the law of New South Wales.
- 28.4. The Customer irrevocably and unconditionally submits to the non-exclusive jurisdiction of the courts of New South Wales and any courts which have jurisdiction to hear appeals from those courts about any proceedings in connection with these Terms and waives any right to object to proceedings being brought in those courts for any reason.
- 28.5. The provisions of the United Nations Convention on Contracts for the International Sale of Goods adopted at Vienna, Austria on 10 April 1980 does not apply to any Goods supplied by the Company to the Customer.

29. FORCE MAJEURE

The Company will not be liable for any breach of contract due to any matter or thing beyond the Company's control (including but not limited to transport stoppages,

transport breakdown, fire, flood, earthquake, acts of God, strikes, lock-outs, work stoppages, wars, riots or civil commotion, intervention of public authority, explosion or accident).

30. DISPUTE RESOLUTION

- 30.1. The Company and/or the Customer must not commence any court proceedings in respect of a dispute arising out of these Terms unless it has complied with this clause 30.
- 30.2. Should at any time a party assert that a dispute exists between the parties arising out of or in connection with these Terms, then that party must submit a written notice ("**Notice of Dispute**") to the other party specifying:
 - 30.2.1. the nature of the dispute that has arisen;
 - 30.2.2. the major issues for determination; and
 - 30.2.3. the relief or outcome being sought.
- 30.3. Within seven (7) days from receipt of the Notice of Dispute, the other party must provide a written response ("**Notice of Response**") stating its position in relation to the dispute, including:
 - 30.3.1. any additional issues that should be referred for determination; and
 - 30.3.2. any comment on the relief or outcome referred to in the Notice of Dispute.
- 30.4. During the fourteen (14) day period after the Notice of Response is issued, the parties must take reasonable steps to seek to resolve the dispute.
- 30.5. If the dispute is not resolved within the period referred to in clause 30.4 then the parties must, within an additional fourteen (14) days agree to refer the dispute to a single expert for determination.
- 30.6. If the parties are unable to agree on a expert within the time stipulated in clause 30.5, then either party may refer the dispute to an expert as nominated by Unisearch Expert Opinion Services, for determination.
- 30.7. The determination of the expert:
 - 30.7.1. must be in writing, accompanied by reasons; and
 - 30.7.2. will be final and binding on the parties as to any findings of fact relating to any matter arising from these Terms.
- 30.8. The parties are to bear their own costs of the dispute and the costs of the expert are to be borne by the party found to be at fault by the expert and, in the event that no such finding is made, the costs are to be borne by the parties equally.

31. WAIVER OF BREACH

No failure by the Company to insist on strict performances of any of these Terms is a waiver of any right or remedy which the Company may have, and is not a waiver of any subsequent breach or default by the Customer.

32. NO ASSIGNMENT

Neither the Contract nor any rights arising under the Contract may be assigned by the Customer without the prior written consent of the Company which is at the Company's absolute discretion.

33. SEVERABILITY

If any provision contained in these Terms is held by a court to be unlawful, invalid or unenforceable, the validity and enforceability of the remaining provisions are not affected.

34. INTERPRETATION

In these Terms:

- 34.1. "**Claim**" means a claim, action, suit, demand, proceeding, damage, loss, cost, expense or liability incurred or suffered by the Company.

- 34.2. **“Company”** means Preformed Line Products (Australia) Pty Limited ABN 27 004 533 877 and its successors and assigns.
- 34.3. **“Consequential Loss or Damages”** means all or any of the following:
- 34.3.1. loss of profit;
 - 34.3.2. loss or denial of opportunity;
 - 34.3.3. loss of use;
 - 34.3.4. loss of revenue;
 - 34.3.5. loss of production;
 - 34.3.6. loss of labour;
 - 34.3.7. loss of access to markets;
 - 34.3.8. loss of goodwill;
 - 34.3.9. loss of anticipated savings;
 - 34.3.10. loss of business reputation including future reputation;
 - 34.3.11. loss arising from adverse publicity;
 - 34.3.12. damage to credit rating;
 - 34.3.13. removal costs;
 - 34.3.14. re-installation costs;
 - 34.3.15. commissioning costs;
 - 34.3.16. increase in operating costs;
 - 34.3.17. increase in maintenance costs;
 - 34.3.18. financial costs;
 - 34.3.19. any indirect, remote, abnormal or unforeseeable loss;
 - 34.3.20. any consequential loss or damage not included in the above; and
 - 34.3.21. any similar loss whether or not in the reasonable contemplation of the parties at the time entry into the Contract,
- and in any case whether arising out of contract or tort (including negligence) or by statute or otherwise, at law or in equity.
- 34.4. **“Contract”** means the contract for the sale of the Goods by the Company to the Customer.
- 34.5. **“Customer”** means the party to whom the Company has agreed to sell the Goods.
- 34.6. **“Goods”** means the goods agreed to be sold by the Company to the Customer.
- 34.7. **“GST”** means the Goods and Services Tax imposed by a *New Tax System (Goods and Services Tax) Act 1999* (Cth) and any related act and/or regulations.
- 34.8. **“Insolvency Representative”** includes but is not limited to a receiver, receiver and manager, administrator, controller, liquidator, provisional liquidator, trustee or similar person.
- 34.9. **“PPSA”** means the *Personal Property Securities Act 2009* (Cth).
- 34.10. **“PPSR”** means the personal property security register created under the PPSA.
- 34.11. **“Terms”** means these terms and conditions of sale as amended from time to time.
- 34.12. **“Tooling”** means any tooling supplied by the Company to the Customer from time to time.

The Connection You Can Count On



SCAN QR CODE
TO DOWNLOAD THIS CATALOGUE



INSULATED CONDUCTOR FITTINGS

FOR LOW & HIGH VOLTAGE ABC, CC & CCT

CATALOGUE

SCAN QR CODE
FOR OTHER PLP CATALOGUES



- ❑ Communications
- ❑ Distribution
- ❑ Insulator
- ❑ Substation
- ❑ Transformer
- ❑ Transmission