

**Your #1 resource for personal  
electrical-safety protection**



# ***SALISBURY***

**W H S A L I S B U R Y . C O M**

**Setting industry standards for over 150 years.**

**ISO 9001:2000 Registered**

## HOW TO USE THIS CD CATALOG

**Adobe Reader - [Salisbury\_Product\_Catalog.pdf]**

File Edit View Document Tools Window Help

48%

**Options**

- SALISBURY
  - HOW TO USE THIS CD CATALOG
  - ABOUT SALISBURY
  - ASTM & USER GUIDE
  - EASY PRINT- ASTM CHART
  - SALISBURY SAFETY PRODUCTS
    - LINE HOSE & COVERS
    - BLANKETS
    - INSULATING PLASTIC GUARDS & COVERS
    - OUTAGE PROTECTION
    - GLOVES & SLEEVES
    - DIELECTRIC BOOTS
    - INSULATED JUMPERS
    - GROUNDING EQUIPMENT
    - HOT STICKS & TOOLS
    - INSULATORS
    - ACCESSORIES
  - SISTER COMPANIES
  - OUR WARRANTY

**Bookmark Tips:**  
Click on to go to page described.  
Clicking on shows more files and page links.

**Hand Tool**  
**Text Select Tool**  
**Zoom In / Out**

**View Tools**  
48%

**Rotate View**

**Navigation Tools**  
1 of 185

**Find / Search**  
Enter product name, number, or description to go to that reference in the catalog.  
Select FIND NEXT to continue your search.  
Narrow your search by entering a more precise description or by going to the proper section and then entering the product name or number.

185

**SALISBURY**

Setting industry standards since 1855. 7520 N Long Ave Skokie IL 60077 Toll Free 877.406.4501 Fax 847.679.2401

## SALISBURY LINE EQUIPMENT

Salisbury has been setting industry standards since 1855. For over 150 years, Salisbury has been the name an entire industry trusts to provide the finest safety products available. Salisbury pioneered the manufacture of linemen's Rubber Protective Equipment in the early 1920's.

Today, Salisbury is the leader in Personal Electrical-Safety Protection. We know that lives depend on the quality of our products, Salisbury's production facilities are all ISO 9001:2000 registered and are equipped and staffed to manufacture products which conform to the highest possible standards. This allowed Salisbury to become the world-wide leader in electrical safety equipment. Salisbury has four plants which manufacture Personal Protective Equipment, Hot Line Equipment, and SALVAR® Polymer Insulators. Only Salisbury produces its own rubber products in its own plants using four methods of rubber manufacture: Injection Molding, Compression/Transfer Molding, Extruding and Dipping. Salisbury's dedication to quality has also been carried over to the manufacture of Hot Line Tools and SALVAR Insulators. As a result, the name *Salisbury* on safety products is your assurance that you are using the finest equipment available for the job.

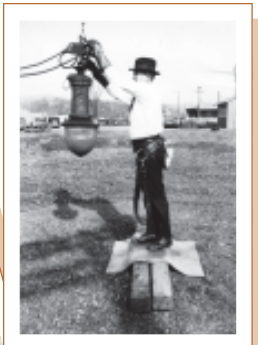
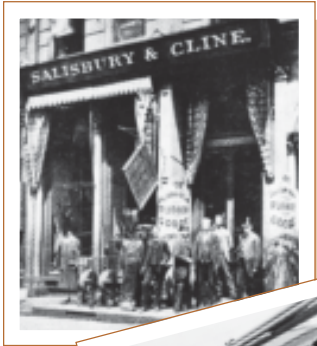
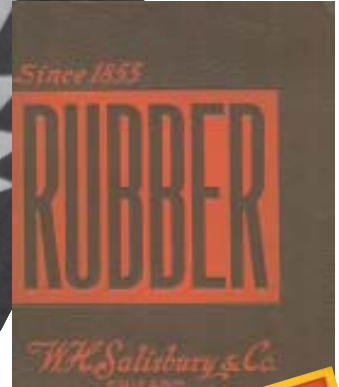
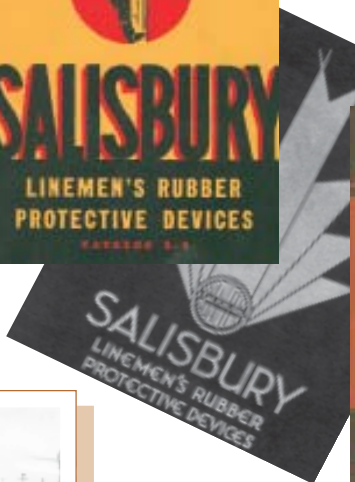
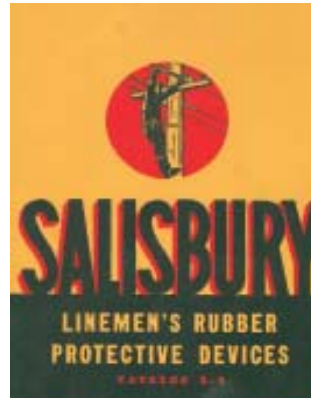
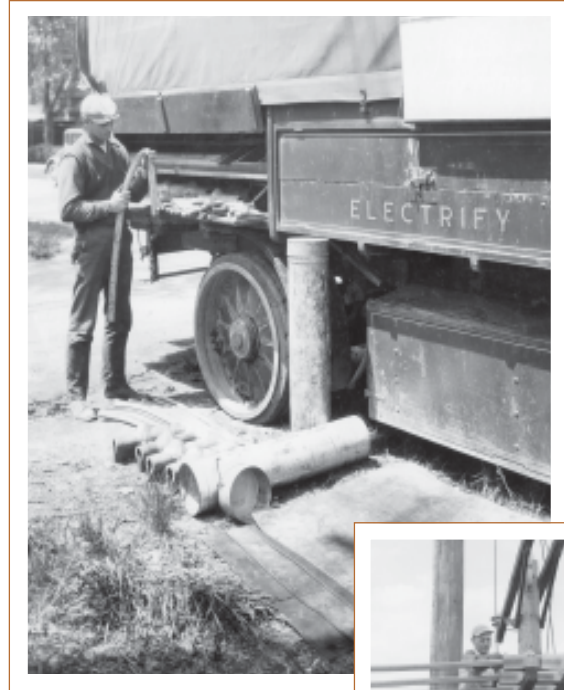



## Caution

Line Equipment should only be used by electrical workers who have been thoroughly trained in its correct and safe use. Training should be conducted in accordance with the employer's work procedures and standards.

## Our Warranty

Salisbury Line Equipment is warranted to be free from defects in materials and workmanship, and to meet the requirements of current ASTM standards at time of shipment. Our only obligation will be, at our option, to replace any portion proving defective or to refund the purchase price thereof. The buyer assumes all other risk, if any, such as the risk of any direct, indirect or consequential loss or damage arising out of the use of, or inability to use, these products.

**THIS WARRANTY IS EXCLUSIVE AND IN LIEU OF THE WARRANTIES OF MERCHANTABILITY, FITNESS FOR PARTICULAR PURPOSE AND ALL OTHER WARRANTIES, EXPRESSED OR IMPLIED, AND MAY NOT BE VARIED OR EXTENDED EXCEPT IN WRITING BY AN AUTHORIZED OFFICIAL OF SALISBURY.**

## ASTM Specifications for Salisbury Equipment

### Gloves, Sleeves and Footwear

ASTM D120	Standard Specification for Rubber Insulating Gloves
ASTM D1051	Standard Specification for Rubber Insulating Sleeves
ASTM F696	Standard Specification for Leather Protectors for Rubber Insulating Gloves and Mittens
ASTM F496	Standard Specification for In-Service Care of Insulating Gloves and Sleeves
ASTM F1116	Standard Test Method for Determining Dielectric Strength of Dielectric Footwear
ASTM F1117	Standard Specification for Dielectric Footwear
ASTM F2413-05	Standard Requirements for Protective Footwear

### Insulating Blanket, Matting and Sheeting

ASTM D 178	Standard Specification for Rubber Insulating Matting
ASTM D1048	Standard Specification for Rubber Insulating Blankets
ASTM F479	Standard Specification for In-Service Care of Insulating Blankets
ASTM F2320	Standard Specification for Rubber Insulating Sheeting
ASTM F1742	Standard Specification for PVC Insulating Sheeting

### Line Hose and Covers

ASTM D1049	Standard Specification for Rubber Insulating Covers
ASTM D1050	Standard Specification for Rubber Insulating Line Hose
ASTM F478	Standard Specification for In-Service care of Insulating Line Hose and Covers

### Hotstick Grounds and Bypass Jumpers

ASTM F711	Standard Specification for Fiberglass Reinforced Plastic (FRP) Rod and Tube used in Live Line Tools
ASTM F1825	Standard Specification for Clampstick Type Live Line Tools
ASTM F855	Standard Specification for Temporary Protective Grounds to be used on De-energized Electric Power Lines & Equipment
ASTM F2321	Standard Specification for Flexible Insulated Temporary By-Pass Jumpers
ASTM F2249	Standard Specification for In-Service Test Methods for Temporary Grounding Jumper Assemblies
	Used on De-Energized Electric Power Lines & Equipment

### Plastic Equipment

ASTM F968	Standard Specification for Electrically Insulating Plastic Guard Equipment for Protection of Workers
ASTM F712	Standard Specification for Test Methods for Electrically Insulating Plastic Guards Equipment for Protection of Workers

### Inspection

ASTM F1236	Guide for Visual Inspection of Electrical Protective Rubber Products
------------	--



OSHA



# ASTM Labeling Chart

*SALISBURY'S* Natural Rubber and SALCOR® Rubber Electrical Protective Equipment

Class Color	Proof Test Voltage AC / DC	Max. Use Voltage AC / DC	Rubber Molded Products Label	Insulating Rubber Glove Label	Insulating Rubber Dipped Sleeve Label	ASTM Specification Reference
00 Beige	2,500 / 10,000	500 / 750				D120 Rubber Insulating Gloves D178 Rubber Insulating Matting D1048 Rubber Insulating Blankets D1049 Rubber Insulating Covers D1050 Rubber Insulating Line Hose D1051 Rubber Insulating Sleeves
0 Red	5,000 / 20,000	1,000 / 1,500				F478 In-Service Care of Line Hose & Covers
1 White	10,000 / 40,000	7,500 / 11,250				F479 In-Service Care of Insulating Blankets F496 In-Service Care of Gloves & Sleeves
2 Yellow	20,000 / 50,000	17,000 / 25,500				F696 Leather Protectors for Insulating Gloves F1236 Inspection Guide for Rubber Products
3 Green	30,000 / 60,000	26,500 / 39,750				F1742 PVC Insulating Sheeting F2320 Rubber Insulating Sheeting
4 Orange	40,000 / 70,000	36,000 / 54,000				Type I- Designates natural rubber. Type II- Designates SALCOR® UV and ozone resistant rubber.

Insulating Gloves and Sleeves must have a color coded label to meet appropriate ASTM Specifications.

REQUEST THE BEST WITH SALISBURY

Part #ASTMCHART  
5M1205

**SALISBURY**  
Setting industry standards since 1855.

7520 N. Long Ave. Skokie IL 60077  
toll free ph. 877.406.4501  
toll free fax 866.824.4922  
whsalisbury.com

## GENERAL CARE & INSPECTION OF SALISBURY RUBBER GOODS

**Type I** natural (non-ozone resistant) and **Type II SALCOR®** synthetic rubber (resistant to ozone) both provide electrical workers with the highest level of electrical insulating protection. However, in order to maintain this level of protection and ensure long life, it is essential that rubber goods are properly cared for. Before each use, rubber goods should be visually inspected for holes, embedded wires, rips or tears, ozone cutting, UV checking and signs of chemical deterioration. For additional information, refer to ASTM F1236, standard guide for visual inspection of electrical protective rubber products.

### Common Problems to Look for



**Cracking & Cutting:** This type of damage is caused by prolonged folding or compressing.



**Chemical Attack:** This photo shows swelling caused by oils and petroleum compounds.



**Contamination:** Discard protectors contaminated with oil or petroleum compounds.



**Snags:** Damage shown is due to wood or metal splinters or other sharp objects.



**UV Checking:** Storing in areas exposed to prolonged sunlight causes UV checking.



**Physical Damage:** Rope burns, deep cuts and punctures are cause for rejection.

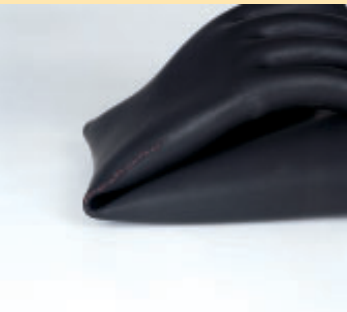

**Avoid Folding Electrical Gloves.** The strain on rubber at a folded point is equal to stretching the glove to twice its length.

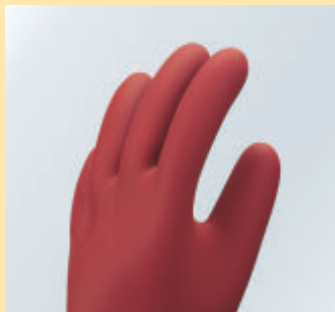

**Avoid Storing Inside Out.** Storing reversed gloves strains the rubber severely and promotes ozone cutting.



**Embedded Wires:** Inspect for embedded wires or metal shavings that could puncture rubber gloves.

#### Manufacturing DATE CODES

G ..... Jan	Z ..... 1976	L ..... 1988	X ..... 2000
O ..... Feb	A ..... 1977	M ..... 1989	Z ..... 2001
D ..... March	B ..... 1978	N ..... 1990	A ..... 2002
H ..... April	C ..... 1979	O ..... 1991	B ..... 2003
E ..... May	D ..... 1980	P ..... 1992	C ..... 2004
L ..... June	E ..... 1981	Q ..... 1993	D ..... 2005
P ..... July	F ..... 1982	R ..... 1994	E ..... 2006
U ..... Aug	G ..... 1983	S ..... 1995	F ..... 2007
S ..... Sept	H ..... 1984	T ..... 1996	G ..... 2008
T ..... Oct	I ..... 1985	U ..... 1997	H ..... 2009
X ..... Nov	J ..... 1986	V ..... 1998	I ..... 2010
Z ..... Dec	K ..... 1987	W ..... 1999	J ..... 2011

#### IMPORTANT:

Rubber Insulating Equipment is for your personal protection against electrical shock.

If it is damaged and in use, a serious injury may result.

Remove damaged equipment immediately from the job.

## GENERAL CARE & INSPECTION OF SALISBURY RUBBER GOODS

### INSULATING RUBBER GLOVE & SLEEVE CARE

#### Before Each Use:

Inspect gloves and sleeves for holes, rips or tears, ozone cutting, UV checking and signs of chemical deterioration. Defective or suspected defective equipment shall not be used.

#### Proper Glove Inflation:

**Inflating gloves makes cuts, tears or ozone damage easier to detect.** Expand *no more than 1.5 times their normal size for Type I, and 1.25 times normal for Type II SALCOR*. Expansion stretches the rubber making cuts, ozone damage and abrasions easy to detect. Listen for escaping air to detect holes. If a portable inflator is unavailable, roll the cuff tightly to trap air inside, then apply pressure to areas of the glove to listen for escaping air. Repeat procedure with glove turned inside out.

#### Sleeve Inspection:

Roll sleeves lengthwise and inspect sleeves along the edge as they are rolled. Rolling will stretch the sleeve along the edge, making cuts, tears and ozone cutting more visible. Repeat with sleeve turned inside out.

#### *Proper storage extends the service life of linemen's gloves and sleeves.*

Folds and creases strain rubber and cause it to crack from ozone prematurely. By storing rubber gloves and sleeves in the right size bag or roll-up, and never forcing more than one pair into each bag, equipment will lie flat and last longer.

Refer to ASTM F1286, standard guide for visual inspection of electrical protective rubber products for additional information.

### RUBBER INSULATING BLANKET CARE

Both Type I and Type II Salcor® elastomeric compound **blankets are subject to chemical damage especially by petroleum base products**. Prompt removal of the contaminant is important to eliminate or reduce swelling and damage to the blanket. If swelling does occur and eventually goes down, the mechanical strength, that is, the resistance to snag, puncture and tear, may be greatly reduced. Depending on the type of contamination involved, the area affected can become spongy and discolored.

#### Blanket Inspection:

Roll blankets in order to locate scratches, tears, abrasions, snags, corona cutting or age-cracking. The blankets should be rolled two times on each side with the second roll at a right angle to the first. Blankets that show any signs of the damage described above should be removed from service.

The ASTM In-Service Specifications call for an electrical retest at an interval not to exceed one year. In addition to the electrical test, a visual inspection of blankets shall be made in the field by a designated person to determine that the blankets are being maintained in satisfactory condition by the users. The frequency of this inspection shall be at intervals of not more than 6 months.

#### Blanket Care & Storage:

Blankets should always be **stored flat or rolled in blanket roll-ups or canisters**. They should **never be folded, creased or compressed** in any manner. When more than one blanket is stored, the preferred method of loading is to roll and insert each blanket into the canister independently. A single blanket can then be removed without removing the others. **Do not use tape** of any type to hold the blankets in the rolled position. The adhesive plasticizer can damage the blanket surfaces. Also, **never stand on or work with blankets on the ground**. Blankets are rated for momentary or accidental contact only.

### RUBBER INSULATING LINE HOSE, HOODS & COVERS CARE

#### Before Each Use:

Rubber insulating line hose, hoods and covers should be **thoroughly inspected inside and out** for cuts, scratches, corona cutting, holes, tears and punctures, rope or wire burns and texture changes such as swelling, softening, hardening, becoming sticky or inelastic.

If mechanical damage extends one quarter the wall thickness of the hose or hood or if there are signs of chemical deterioration, they should be removed from service. Line hose, hoods and covers should be **wiped clean of any chemical contaminant** as soon as practical. They should be **stored in a relaxed position**, without distortion and mechanical stress. **Tape shall not be used** to secure these items when shipped or stored.

Frequently inspect line hose, hoods and covers in the field. Remove from service if damaged. Defective or suspected defective equipment shall not be used.

## SALISBURY

Setting industry standards since 1855. 7520 N Long Ave Skokie IL 60077 Toll Free 877.406.4501 Fax 847.679.2401

# CONTENTS



## A. Line Hose & Covers

---



## B. Blankets

---



## C. Plastic Guards & Covers

---



## D. Outage Protection

---



## E. Gloves & Sleeves

---



## F. Dielectric Boots

---



## G. Insulated Jumpers

---



## H. Grounding Equipment

---



## I. Hot Sticks & Tools

---

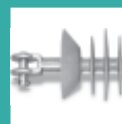

## J. Insulators

---



## K. Voltage Detectors

---



## X. Accessories

---



# Line Hose & Covers



# INSULATING LINE HOSE AND COVERS

## LINE HOSE SELECTION CHART

The connector, formed at one end, receives and overlaps the end of an adjoining hose for a distance of 6.5" (165mm).

Use the chart below to determine the maximum conductor diameter recommended for use with each size line hose. For ease of installation and to minimize the potential of flashover through the overlapping lips, line hose is always sized larger than the maximum conductor diameter.



Salisbury Line Hose is available in four ASTM D1050 styles, as shown below:



**Style A**  
Class 2 & 3  
*Straight Conventional*

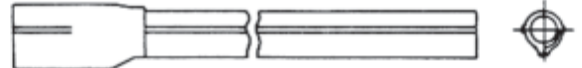

**Style B**  
Class 2 & 3  
*Connector End Conventional*



**Style C**  
Class 4  
*Extended Lip Straight*



**Style D**  
Class 4  
*Extended Lip Connector End*

Line Hose Size Selector Chart								
I.D. of Line Hose in. (mm)	Conductors and Diameters in. (mm)							
	4/0 .46 (12)	266,800 .609 (15.5)	336,400 .677 (17)	477,000 .793 (20)	556,500 .858 (22)	795,000 1.028 (26)	954,000 1.126 (29)	1,351,500 1.34 (35)
1 (25)	20kV Conventional							
1 1/4 (31)	20kV Conventional							
1 1/2 (38)	30kV Conventional							
1 1/2 (38)	40kV SU System							
2 (51)	30kV Conventional							
2 (51)	40kV SU System							
2 1/2 (64)	30kV Conventional							
2 1/2 (64)	40kV SU System							

## LINE HOSE & CONNECTORS

### CONVENTIONAL SYSTEM

**Conventional Style Line Hose** is available in orange Type II SALCOR®. SALCOR remains flexible even in cold weather and it is not damaged by ozone or ultraviolet rays. Each line hose has Salisbury's RIB-GRIP Locking System. The straight or connector end style is available in three sizes: 1" and 1.25" I.D. rated at 17kV, Class 2 and 1.5" I.D. rated at 26.5kV, Class 3.

**Straight style SALCOR hose** is also available in 2" or 2.5" I.D. rated at Class 3.





**Conventional Line Hose Connectors** are made from Type II orange SALCOR and can be used on 1", 1.25", or 1.5" I.D. conventional line hose. To connect 2" and 2.5" I.D. conventional line hose, use the SU System Connector.

#### *The tightest grip in the industry.*

The self-locking lip, Salisbury patented, prevents line hose from coming off the conductor *after* an installation is complete. Often, as a lineman is working on an installation and making adjustments, the angle of connection shifts, causing line hose and covers to separate. To prevent this, Salisbury developed an ingenious solution for ensuring that any two protective devices would hold together yet still be easy for a lineman to assemble and take apart.



**RIB GRIP®** construction takes advantage of rubber's natural tendency to grip and tighten its grip through compression. By creating curving rib configurations slit at a specific angle, two pieces easily slip together but resist coming apart. To quickly disengage the lineman needs only to compress the rubber on either side.

RIB GRIP Locking System	
	
<p><i>Sectional view of typical insulator cover showing arrangement of ribs. Ribs are engineered to grip the serrations on its corresponding line hose, regardless of angle.</i></p>	<p><i>A row of serrations on both sides of connector line hose grips snugly inside the large arm of insulator covers.</i></p>
	
<p><i>Saw-tooth serrations on the ends of line hose are angled to make it easy to insert, but resist coming apart.</i></p>	<p><i>Connector end line hose with rubber ribs that grasp tightly and hold an adjoining length of hose.</i></p>

## LINE HOSE & CONNECTORS

### CONVENTIONAL SYSTEM

Cat. No.	ASTM Class	Type	Dimensions I.D. x Length in. (mm)	Weight ea. lbs. (kgs)
<b>SALCOR® Straight Line Hose</b>				
OR100-3	2	II	1" x 3' (25 x 915)	3 (1.4)
OR100-45	2	II	1" x 4.5' (25 x 1372)	4 (1.8)
OR100-6	2	II	1" x 6' (25 x 1820)	5.5 (2.5)
OR125-3	2	II	1.25" x 3' (31.5 x 915)	4 (1.8)
OR125-45	2	II	1.25" x 4.5' (31.5 x 1372)	6 (2.7)
OR125-6	2	II	1.25" x 6' (31.5 x 1820)	7.5 (3.4)
OR150-3	3	II	1.5" x 3' (40 x 915)	5 (2.3)
OR150-45	3	II	1.5" x 4.5' (40 x 1372)	7 (3.2)
OR150-6	3	II	1.5" x 6' (40 x 1820)	9.5 (4.3)
OR200-3	3	II	2" x 3' (50 x 915)	5.5 (2.5)
OR200-45	3	II	2" x 4.5' (50 x 1372)	8 (3.6)
OR200-6	3	II	2" x 6' (50 x 1820)	11 (5.0)
OR250-3	3	II	2.5" x 3' (63 x 915)	7 (3.2)
OR250-45	3	II	2.5" x 4.5' (63 x 1372)	10.5 (4.8)
OR250-6	3	II	2.5" x 6' (63 x 1820)	14 (6.4)
<b>SALCOR Connector End Line Hose</b>				
OR100-3C	2	II	1" x 3' (25 x 915)	3.5 (1.6)
OR100-45C	2	II	1" x 4.5' (25 x 1372)	5 (2.3)
OR100-6C	2	II	1" x 6' (25 x 1820)	6.5 (2.9)
OR125-3C	2	II	1.25" x 3' (31.5 x 915)	4.5 (2.0)
OR125-45C	2	II	1.25" x 4.5' (31.5 x 1372)	6.5 (2.9)
OR125-6C	2	II	1.25" x 6' (31.5 x 1820)	9 (4.1)
OR150-3C	3	II	1.5" x 3' (40 x 915)	6 (2.7)
OR150-45C	3	II	1.5" x 4.5' (40 x 1372)	8 (3.6)
OR150-6C	3	II	1.5" x 6' (40 x 1820)	9 (4.1)
<b>Line Hose Connectors</b>				
ORC100	2	II	1" x 12" (25.4 x 305)	2.5 (1.1)
ORC125	2	II	1.25" x 12" (32 x 305)	3.5 (1.6)
ORC150	3	II	1.5" x 12" (38 x 305)	3 (1.4)

All Line Hose complies with current ASTM D1050 specifications.



# SALISBURY

Setting industry standards since 1855. 7520 N Long Ave Skokie IL 60077 Toll Free 877.406.4501 Fax 847.679.2401

# PROTECTORS & COVERS

## CONVENTIONAL SYSTEM

**Insulator Covers**, in orange, weather resistant Type II SALCOR®, are used with conventional line hose to cover pin-type insulators. All covers feature RIB-GRIP construction to lock to the underside of the insulators. The large diameter arm overlaps the small arm of the adjoining cover on double arm constructions which provides complete insulation at the joint regardless of the varying distance between pins.

**Dead End Protectors** cover 4.25" and 6" bells or polymer insulators with a skirt diameter of less than 6". The protectors are made from orange Type II SALCOR with RIB-GRIP construction. **OR101** has outer ribs that allow it to be used with 2" and 2.5" I.D. Conventional Line Hose when using the UC2 connector. The smaller **OR114** may also be used to cover transformer bushings up to 4.75" in diameter. **OR124** can cover polymer insulators up to 4.75" in diameter and 25" overall length including hardware. Replacement Straps are available.

To work on live lines safely, conductors encased in a line hose should never be placed directly on a cross arm. **Cross Arm Covers** reduce electrical stresses on line hose or jumpers. Cross Arm Covers fit standard cross arm pin spacing and each unit has interior ribs to minimize shifting on the arm.

Flexible **Cutout Covers** can be used for overhead cutouts as well as for underground pad-mount applications. Cutout Covers comply with the current ASTM D1049 (ASTM Specifications for Rubber Insulating Covers) specifications.

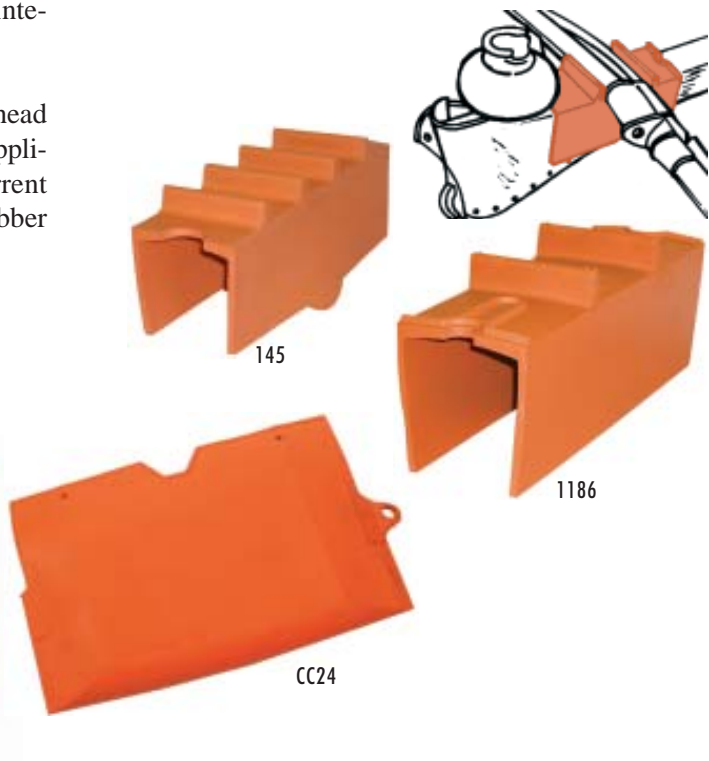

# PROTECTORS & COVERS

## CONVENTIONAL SYSTEM

Cat. No.	Class	Description in (mm)		Overall Dimensions in (mm)	Weight ea. lbs. (kgs)
for use with					
<b>INSULATOR COVERS</b>		Insulator Class	Line Hose Size		
OFRG	2	55-1/2/3	1" (25.4)	14.5" x 5" (368 x 127)	5 (2.3)
OJRG	2	55-4	1" (25.4)	16" x 6.5" (406 x 165)	6 (2.7)
OKRG	3	55-5	1.25", 1.5" (32, 38)	16" x 8" (406 x 203)	7 (3.2)
for use with					
<b>DEAD END PROTECTORS</b>		Bell Size	Line Hose Size		
OR101	2	2-6" (152.4)	1" (25.4)	6.5" x 23" (165 x 584)	10 (4.6)
OR114	3	1-4.25" (108)	1.5" (38)	4.75" x 14" (121 x 356)	4 (1.8)
OR124	3	2-4.25" (108)	1.5" (38)	4.75" x 29" (121 x 737)	7.5 (3.4)
<b>CROSS ARM COVERS</b>		Use on Cross Arms up to			
145	2	4" x 4.5" (102 x 114)		14.5" x 4.63" x 4.15" (368 x 117 x 105)	3 (1.4)
1186	4	5.5" x 6" (140 x 152)		17.0" x 6.0" x 5.5" (432 x 152 x 140)	5 (2.3)
<b>CUTOUT COVERS</b>					
CC24	2			24" x 15" x 3.5" (600 x 376 x 88)	5 (2.3)
CC30	4			30" x 20" x 7" (750 x 500 x 175)	10 (4.5)
<b>REPLACEMENT STRAPS</b>					
N24		For 114 & 124 Series		.75 x 30 (18 x 588)	2 oz. (56.7 g)
N36		For 101 Series		.75 x 36 (18 x 882)	2 oz. (56.7 g)

All covers comply with current ASTM D1049 specifications.

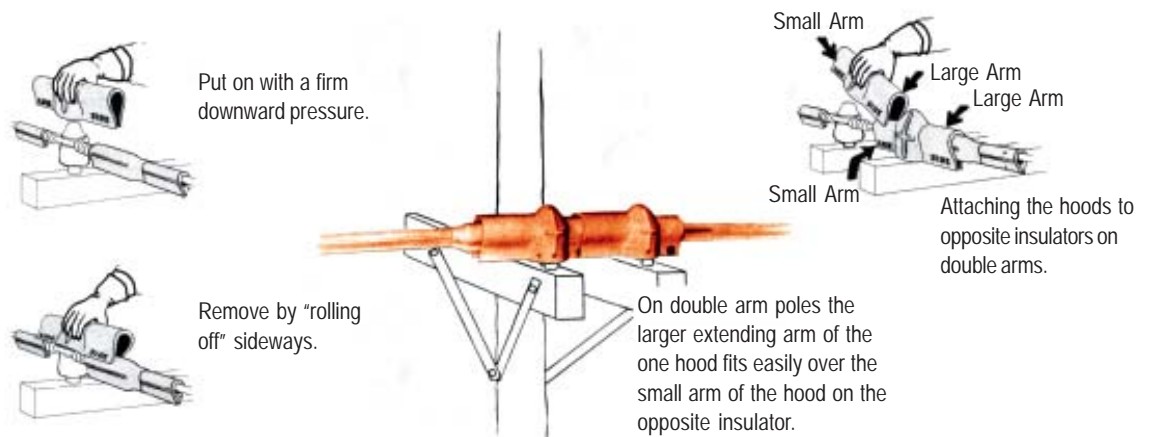

## LINE HOSE

### EXTENDED LIP SU SYSTEM

The **Extended Lip SU System** is the only complete flexible cover-up available for use on voltages through 34.5kV. Extremely versatile, it may be installed by hand, wearing rubber insulating gloves, from an insulated aerial device or platform, or with hot sticks using the SU applicators.

Manufactured from superior SALCOR® Type II elastomer, it is resistant to the effects of ozone and ultraviolet deterioration. It remains flexible even at sub-zero temperatures.

Salisbury's RIB GRIP® construction securely interlocks with its corresponding covers and connectors. Tapered lips facilitate easy starting on the conductors. The contour cut ends accommodate the skirts of pin type insulators and permit the hose to cover the line snug to a saddle or clamp.

Available as **Straight Line Hose** or with a **Connector End** for easier connection of line hose and covers. A lifting eye is molded on the connector end for removal with hot sticks. Line hose is also available with the #2323 Shot Gun Eye Assembly. Just add a suffix of "E" to the catalog number to order the #2323 Shot Gun Assembly installed on the hose or order the #2323 separately.

**SU System Connectors** are made from orange SALCOR Type II. RIB-GRIP construction is used to ensure a strong lock to the straight lengths of SU System Line Hose and covers. The UC2 is used to connect Extended Lip Hose to PTHL and LRG Insulator Covers, OR134 Dead End Protectors, and 2" (51mm) and 2.5" (64mm) SU System and Conventional Line Hose.



SU150-3C



SU150-45



UC

Cat. No.	Dimensions -- I.D.	in. (mm) Length	Weight ea. lbs. (kgs)
<b>STRAIGHT LINE HOSE Class 4, Type II</b>			
<b>SU150-3</b>	1.5" (38)	3' (915)	6 (2.7)
<b>SU150-45</b>	1.5" (38)	4.5' (1372)	8.5 (3.8)
<b>SU150-6</b>	1.5" (38)	6' (1829)	12 (5.4)
<b>SU200-3</b>	2" (51)	3' (915)	6 (2.7)
<b>SU200-45</b>	2" (51)	4.5' (1372)	10 (4.5)
<b>SU200-6</b>	2" (51)	6' (1829)	14 (6.4)
<b>SU250-3</b>	2.5" (63.5)	3' (915)	7 (3.2)
<b>SU250-45</b>	2.5" (63.5)	4.5' (1372)	11 (5.0)
<b>SU250-6</b>	2.5" (63.5)	6' (1829)	15 (6.8)
<b>CONNECTOR END LINE HOSE Class 4, Type II</b>			
<b>SU150-3C</b>	1.5" (38)	3' (915)	7 (3.2)
<b>SU150-45C</b>	1.5" (38)	4.5' (1372)	9 (4.1)
<b>SU150-6C</b>	1.5" (38)	6' (1829)	12 (5.4)
<b>SU SYSTEM CONNECTORS Class 4, Type II ASTM D1049</b>			
	Length x Height	Use w/ Line Hose I.D.	
UC	10.5" x 6" (263 x 150)	1.5" (40)	2 (.9)
UC2	10.5" x 7.75" (263 x 194)	2" & 2.5" (51 & 64)	3 (1.4)

Add Suffix "E" to Catalog Number to order with #2323 Shot Gun Eye Assembly (see page A-13).

Complies with current ASTM D1050 specifications.

## DEAD END PROTECTORS

### EXTENDED LIP SU SYSTEM

**Dead End Protectors** quickly cover dead end bells or polymer insulators providing complete electrical protection for Class 3 and Class 4 applications.

Easily installed and removed from an insulated platform or aerial device with rubber gloves or SU System Applicators.

All styles have RIB-GRIP® construction to interlock with 1.5" (38mm) I.D. line hose. The Class 3 U106 and U110 must be used with Connector End style line hose or separate Line Hose Connectors. OR134, cLASS 4, accepts Straight Line Hose. The outer ribs interlock with 2" and 2.5" I.D. line hose when the UC2 SU System Connector is used.



OR134



U110



RIB-GRIP® Construction

Cat. No.	ASTM Class / Type	Fits Bell Size in. (mm)	Dimensions in. (mm)		Color	Weight ea. lbs. (kgs)
			I.D. body	Overall Length		
<b>DEAD END PROTECTORS</b>						
OR134	4 / II	3-4.25 (108)	5 (127)	37 (940)	Orange	13 (6)
Add Suffix "E" to Catalog Number to order with #2323 Shot Gun Eye Assembly (see page A-13).						
U106	3 / II	2-6 (152)	7 (178)	28.5 (724)	Black	6 (2.7)
U110	3 / II	2-10 (254)	10.5 (267)	28.5 (724)	Black	10 (4.5)
Add Suffix "E" to Catalog Number to order with #2340 Shot Gun Eye Assembly (see page A-13).						

All Protectors comply with current ASTM D1049 specifications.



## INSULATOR COVERS

### EXTENDED LIP SU SYSTEM

The **UH Pin-Type Cover** covers insulators up to ANSI standard C29.5 Class 5. The sides are cut to be used on small insulators without resting on the crossarm. When covering a 7" diameter insulator on a double arm construction, the ends of the cover will meet flush on 10.5" pin centers.

The **LRG SU System Pin-Type Cover** fits insulators 10.5" (267mm) in diameter and is used with 2.5" (64mm) Class 4 Extended Lip SU System Line Hose. Always use clamp pins to secure the device into position. Pinning rings have been placed on the cover's arms to prevent separation.

**Post-Type Insulator Covers** interlock with 1.5" (38mm) Class 4 Extended Lip SU System or Conventional Line Hose. The **PTHS** for insulators up to 12" (305mm) and the **PTHL** for insulators up to 16" (406mm) in height. The **PTHL** cover also has external ribs on the ears which secures 2.5" (64mm) I.D. line hose. Always use clamp pins to secure the device into position.

The Class 4 **MRG Universal Cover** covers pin-type insulators through 8.5" (216mm) diameter and 13.8kV post-type insulators. A trim bead permits use on both 35kV and 15kV crossarm construction.

The **USC Stirrup Cover** is a lightweight cover that can be installed using rubber gloves or a hot stick. The USC also feature RIB-GRIP construction and is meant to be used with Extended Lip SU Systems or Conventional Line Hose.

All covers are made from orange SALCOR® and feature RIB-GRIP® Construction. They can be installed with a hot stick or rubber gloves. All covers comply with ASTM D1049 specifications.



UH

LRG



PTHS

PTHL



MRG



USC



USC (side view)



Application of USC.

# INSULATOR COVERS

## EXTENDED LIP SU SYSTEM



Cat. No.	ASTM Class / Type	Fits Line Hose in (mm)	Fits Insul. Max Dia in (mm)	For Use w/ Insul. Class	Overall Dimensions-in.(mm) I.D. body	Height	Weight ea. lbs. (kgs)
<b>PIN TYPE Insulator Covers</b>							
LRG	4 / II	2.5 (63)	10.5 (263)	55-6	12 (305)	16 (400)	8 (3.6)
MRG	4 / II	1.5-2.5 (40-63)	8.5 (213)	Pin Type 55-5	9 (221)	12.25 (306)	7 (3.2)
				Post Type 13.2kV F Neck			
				Post Type 13.2kV C Neck			
Add Suffix "E" to Catalog Number to order with #2359 Shot Gun Eye Assembly (see page A-13).							
UH	3 / II	1.5 (40)	7 (175)	55-1, 2, 3, 4, 5	7.5 (184)	12 (300)	6 (4.4)
<b>POST TYPE Insulator Covers</b>							
PTHL	4 / II	1.5-2.5 (40-63)	6.5 (163)	57-2	7 (172)	16 (400)	8 (3.6)
PTHS	4 / II	1.5 (40)	7 (175)	57-2	7.5 (184)	12 (300)	4 (1.8)
<b>Stirrup Cover</b>							
USC	4 / II	1.5 (40)			14 (263)	15.5 (388)	5 (2.3)

All Covers comply with current ASTM D1049 specifications.

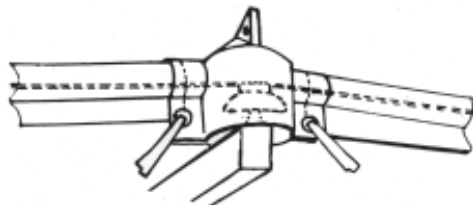

Pin Type Insulator Cover - LRG or MRG  
Line Hose is inserted  
in the ears of the cover.

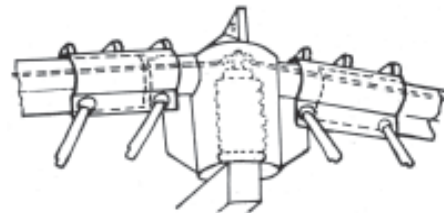

Post Type Insulator Cover  
PTHL 2.5" (64mm) Line Hose held  
in place with UC2 Connector.

## CABLE END CAPS & ARRESTER COVERS

Cable End Caps are applied with rubber gloves. They are used on high voltage distribution cable ends found in vaults, cubicles and substations when cable remains energized during work. Cable End Caps are made from Type II orange SALCOR®.

**Self-securing Cable End Caps** for Underground Distribution are rated at 20kV, and have a minimum wall thickness of .25". They keep moisture and contamination off trimmed cable ends. The self-securing slot keeps the cable locked safely inside the end cap. These Cable End Caps are applied with rubber gloves.

**Lightning Arrester Covers** are made from Type II orange SALCOR. The slot allows the cap to fit directly over the energized lightning arrester and the line connection. Lightning Arrester Covers can be applied with rubber gloves or a hot stick.



Cat. No.	ASTM Class	Type	Dimensions in. ( mm ) I.D. x Length	For use w/ Cable Size	Weight ea. lbs. ( kgs )
<b>SELF-SECURING CABLE END CAPS</b>					
173	2	II	.81" x 6" ( 21 x 152 )	#4 to #4/0 AWG	.25 ( .1 )
117	2	II	1.38" x 10" ( 35 x 254 )	#4/0 to 500 MCM	.50 ( .23 )
177	2	II	2.25" x 12" ( 57 x 305 )	350 to 750 MCM	.75 ( .35 )
178	2	II	3.19" x 16" ( 81 x 406 )	800 to 1000 MCM	1.5 ( .7 )
<b>LIGHTNING ARRESTER COVERS</b>					
536A	4	II	4.5 x 15 ( 113 x 375 )	-	3 ( 1.4 )
636A	4	II	5.5 x 22 ( 138 x 550 )	-	5 ( 2.3 )

All Covers comply with current ASTM D1049 specifications.

## SU SYSTEM APPLICATORS

The Extended Lip SU System may be installed by using rubber gloves or hot sticks on distribution voltages up to 34.5kV.

The Shot Gun Eye Assembly for the SU System equipment may be purchased separately for installation on the appropriate cover-up device.

The addition of these eye assemblies enable all SU System equipment to be easily handled with a standard shotgun stick.

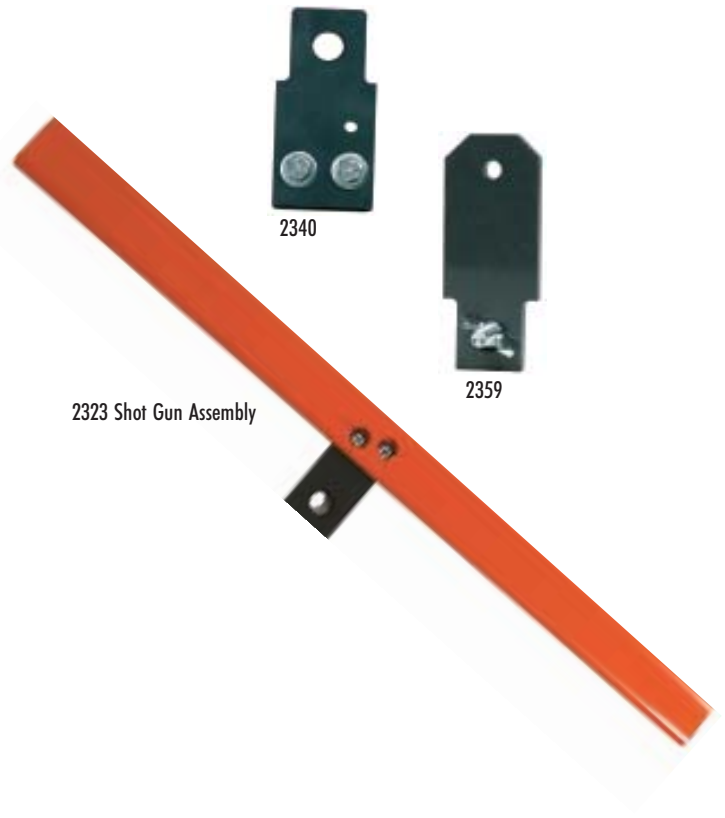

2323 Shotgun Assembly allows easy installation



2323 Shotgun Assembly attaches easily to SU Systems

Cat. No.	Description	For Use w/ Hot Stick Style	Weight ea. lbs. ( kgs )
2323	Shot Gun Eye Assembly for SU Hose / OR134	Shot Gun	1 ( .4 )
2359	Eye Assembly for SU System Insulator Covers	Shot Gun	.5 ( .2 )
2340	Eye Assembly for SU System D.E. Protectors	Shot Gun	.5 ( .2 )



TH111



TD



Tagging Device fits over the head of switch sticks for application.

The **TD Tagging Device**, made from molded orange SALCOR®, is used to tag opened disconnect switches. It allows “Hold” cards to be placed on the circuit and fits over the heads of 1-1/4” (32 mm) and 1-1/2” (38 mm) switch sticks.

The **TH111 Meter Terminal Cover** is used to avoid accidental contact with energized parts on 100 and 200 Amp single phase meter sockets. Made of orange SALCOR.



SC5



Spade Cover Application

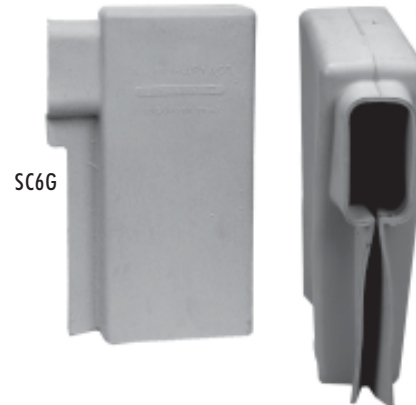

SC6G

**Spade Covers** are easily installed to provide temporary insulation when working in padmount transformers and other electrical apparatus. If spade covers are securely held in place, they may be left on spades or connectors indefinitely for front end protection. The larger SC-5 is also used to cover primary elbows as well as the larger and longer multiple lead primary and secondary fittings and lugs used in underground enclosures and vaults. Molded from flexible SALCOR, they have excellent aging and weathering characteristics. The opening at the top end of the slot holds the cover on to the terminal. Wide lips extending along the slot provide additional protection over the connection.

Cat. No.	Description / Dimensions in. ( mm )	Weight ea. lbs. ( kgs )
<b>TAGGING DEVICE</b>		
<b>TD</b>	7.25 (184) longslot: 2.13 x .63 (5 4 x 16) cup: 2.5 x 1.75 ( 64 x 44 )	.25 ( .1 )
<b>METER TERMINAL COVER</b>		
<b>TH111</b>	3 x 3.5 x 1.5 ( 76 x 89 x 38 )	1.6oz. ( .05 )
<b>SPADE COVER - CLASS 2, TYPE II, ASTM D1049</b>		
<b>SC4</b>	2.75 x 4.4 x 10.75 ( 70 x 112 x 273 )	1.4 ( .5 )
<b>SC5</b>	3 x 6 x 10 ( 76 x 152 x 254 )	2 ( .9 )
<b>SC6</b>	3 x 6 x 10 ( 76 x 152 x 254 )	1.4 ( .5 )
<b>SC6G</b>	3 x 6 x 10 ( 76 x 152 x 254 )	1.4 ( .5 )

## BLANKETS

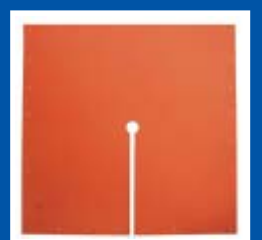

Only Salisbury formulates compounds, mixes, molds and tests blankets in our own ISO 9000:2001 registered facilities.

## General Care & Inspection of Salisbury Rubber Goods

**Type I** natural (non-ozone resistant) and **Type II SALCOR®** synthetic rubber (resistant to ozone) both provide electrical workers with the highest level of electrical insulating protection. However, in order to maintain this level of protection and ensure long life, it is essential that rubber goods are properly cared for. Before each use, rubber goods should be visually inspected for holes, embedded wires, rips or tears, ozone cutting, UV checking and signs of chemical deterioration. For additional information, refer to ASTM F1236, standard guide for visual inspection of electrical protective rubber products.

## INSULATING BLANKETS

### Eyelet Style

#### THE SALISBURY ADVANTAGE

##### HIGH QUALITY

Salisbury's Type II Salcor® Blankets are of the highest quality available today. They will hold their color and flexibility, and will maintain physical properties and dielectric strength, required by ASTM standard, in the field longer than any other blanket on the market.

##### OZONE RESISTANT

The Orange Salcor® is manufactured from a well researched blend of prime EPDM, which is naturally resistant to Ozone. This blend of Prime EPDM offers superb flexibility; similar to that of a Type I natural rubber blanket. This ensures the Salisbury Type II Salcor® blanket will pass the ASTM D 1048 Ozone Tests both, Method A and Method B.

**Eyelet Style Insulating Blankets** were designed to be easily secured in place by using blanket pins, Snap Buttons or Ty-Straps (*available on page B-9*) Eyelet blankets are flexible and feature a reinforced beaded edge and eyelets for added strength and tear-resistance.

Our **Zip-On Style (Zip)** features one-inch wide strips of hook and pile double stitched to the blanket with nylon thread, so installation and removal is safe and fast.

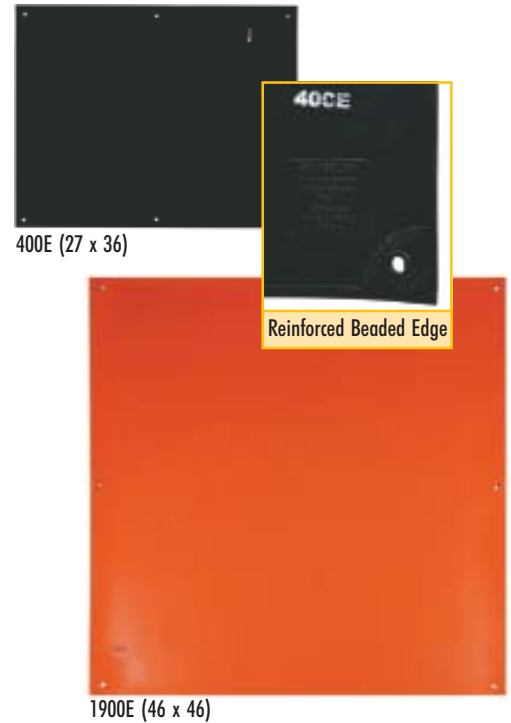

Cat. No.	Eyelets/ Style	ASTM Class	Type	Size in. (mm)	Color	Weight ea. lbs. (kgs)
12	28	2	II	22 x 22 ( 559 x 559 )	Black	3 ( 1.4 )
13	28	4	II	22 x 22 ( 559 x 559 )	Orange	3 ( 1.4 )
13-10	10	4	II	22 x 22 ( 559 x 559 )	Orange	3 ( 1.4 )
400E	6	2	II	27 x 36 ( 686 x 914 )	Black	6 ( 2.3 )
1000E	6	4	II	27 x 36 ( 686 x 914 )	Orange	6 ( 2.3 )
1001E	6	4	II	27 x 36 ( 686 x 914 )	Black	6 ( 2.3 )
300E	6	2	I	36 x 36 ( 914 x 914 )	Black	8 ( 3.6 )
900E	6	4	II	36 x 36 ( 914 x 914 )	Orange	8 ( 3.6 )
901E	6	4	II	36 x 36 ( 914 x 914 )	Black	8 ( 3.6 )
1500	28	2	II	36 x 36 ( 914 x 914 )	Black	8 ( 3.6 )
1700	28	4	II	36 x 36 ( 914 x 914 )	Orange	8 ( 3.6 )
1900E	6	4	II	46 x 46 ( 1168 x 1168 )	Orange	12 ( 5.4 )

#### ZIP-ON STYLE

1830S	Zip	4	II	18x36 ( 457x914 )	Orange	3.5 ( 1.6 )
1000EV	Zip	4	II	27x36 ( 686x914 )	Orange	8.1 ( 3.7 )
900EV	Zip	4	II	36x36 ( 914x914 )	Orange	8.5 ( 3.9 )

All blankets comply with current ASTM D1048 specifications.

# SALISBURY

Setting industry standards since 1855. 7520 N Long Ave Skokie IL 60077 Toll Free 877.406.4501 Fax 847.679.2401



## INSULATING BLANKETS

### Slotted Style

**Slotted Style Insulating Blankets** are made of Type II SALCOR® rubber and designed for increased versatility and flexibility in special cover-up situations. Use for covering ridge pins, cross arms with insulators or any place a wire, pin or projection interferes with proper placement of other cover-up devices.

Three sizes are available with reinforced beaded edges and reinforced eyelets which can be secured with blanket pins, Snap Buttons or Ty-straps (*available on Page 9*). Our 36”(914mm) slotted blanket is also available with 2”(51mm) or 4.5”(114mm) center holes and with hook and pile (Zip Style). Our 46”(1168mm) slotted blanket features extra thickness at the end of the slot for added strength.

Our **Zip-On Style (Zip)** features one-inch wide strips of hook and pile double stitched to the blanket with nylon thread, so installation and removal is safe and fast.

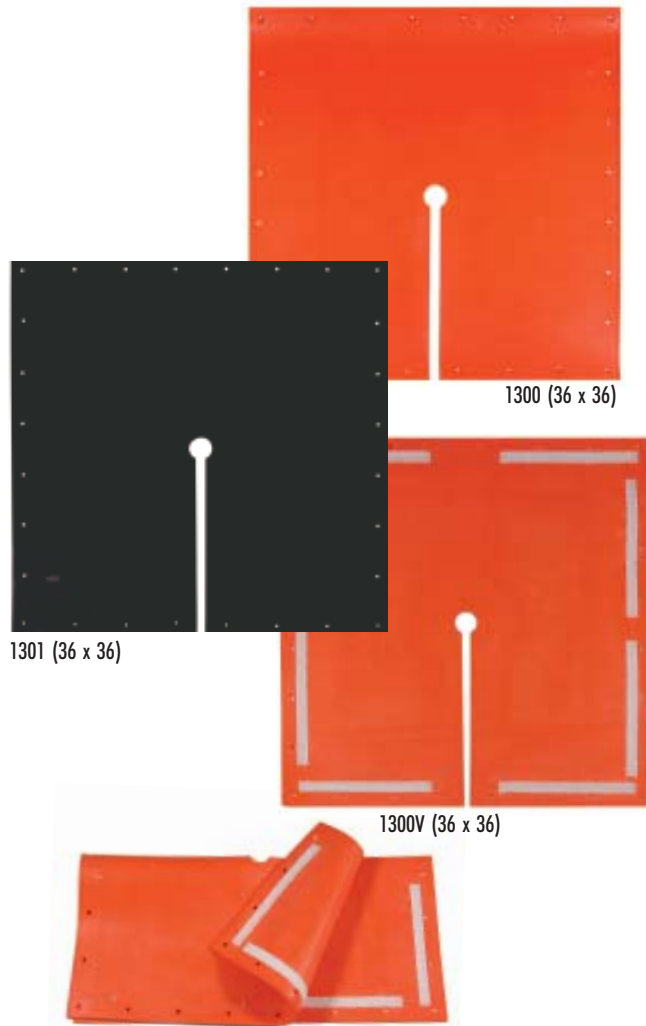

Cat. No.	Eyelets	ASTM Class	Type	Size in. ( mm )	Color	Weight ea. lbs. ( kgs )
14	28	2	II	22 x 22 ( 559 x 559 )	Black	2.5 ( 1.1 )
15	28	4	II	22 x 22 ( 559 x 559 )	Orange	2.5 ( 1.1 )
15-1	28	4	II	22 x 22 ( 559 x 559 )	Black	2.5 ( 1.1 )
1100	28	2	II	36 x 36 ( 914 x 914 )	Black	7 ( 3.2 )
1300	28	4	II	36 x 36 ( 914 x 914 )	Orange	7 ( 3.2 )
1301	28	4	II	36 x 36 ( 914 x 914 )	Black	7 ( 3.2 )
1302	2" hole	4	II	36 x 36 ( 914 x 914 )	Orange	7 ( 3.2 )
1304	4.5" hole	4	II	36 x 36 ( 914 x 914 )	Orange	7 ( 3.2 )
1400E	10	2	II	46 x 46 ( 1168 x 1168 )	Black	12 ( 5.4 )
1800E	10	4	II	46 x 46 ( 1168 x 1168 )	Orange	11 ( 5 )
<b>ZIP-ON STYLE</b>						
1300V	Zip	4	II	36x36 ( 914x914 )	Orange	7 ( 3.2 )

All blankets comply with current ASTM D1048 specifications.

## INSULATING BLANKETS

### Without Eyelets

#### THE SALISBURY ADVANTAGE

##### CONSISTENCY

The Salisbury blanket is manufactured from materials that are precisely measured in an automated weighing system to ensure batch-to-batch consistency.

##### VALUE

Salcor® blankets will last longer and provide maximum value and protection. Not all rubber blankets are manufactured equally. Ask for the best, ask for Salisbury's rubber insulating blankets.

**Salisbury Insulating Blankets without Eyelets** are available in Class 2 and Class 4 in two types of material: Type I natural rubber, and Type II SALCOR®, which is a highly flexible, corona-resistant polymer with excellent aging and weathering qualities.

Salisbury insulating blankets feature a reinforced beaded edge for added strength and tear-resistance.



186 (18 x 36)



300 (36 x 36)

Cat. No.	ASTM Class	Type	Size in. ( mm )	Color	Weight ea. lbs. ( kgs )
186	4	II	18 x 36 ( 457 x 914 )	Orange	3.5 ( 7.7 )
1000	4	II	27 x 36 ( 685 x 914 )	Orange	6 ( 2.3 )
300	2	I	36 x 36 ( 914 x 914 )	Black	8 ( 3.6 )
1900	4	II	46 x 46 ( 1168 x 1168 )	Orange	12 ( 5.4 )

All blankets comply with current ASTM D1048 specifications.



# SALISBURY

Setting industry standards since 1855. 7520 N Long Ave Skokie IL 60077 Toll Free 877.406.4501 Fax 847.679.2401

## LOW VOLTAGE BLANKETS

### With & without hook and pile

**Low Voltage Insulating Blankets** are made of Type II SALCOR® rubber. Insulating blankets are available with or without hook and pile (Zip) or Plain style, as noted in the chart below.

Covering energized equipment is easier than ever using Salisbury's Zip-On blankets. Our **Zip-On Style (Zip)** features one-inch wide strips of hook and pile double stitched to the blanket with nylon thread, so installation and removal is safe and fast. Zip-On blankets can be manufactured to fit special requirements. Contact your Salisbury representative for more information.



1212YLV



1212YLVNV



1212YLV  
Back

Cat. No.	Style	ASTM Class	Type	Size in. ( mm )	Color	Weight ea. lbs. ( kgs )
1212YLV	Zip	0	II	12x12 ( 305x305 )	Yellow	1 ( .45 )
1212YLVNV	Plain	0	II	12x12 ( 305x305 )	Yellow	1 ( .45 )
1236YLV	Zip	0	II	12x36 ( 305x914 )	Yellow	1.5 ( .48 )
1236YLVNV	Plain	0	II	12x36 ( 305x914 )	Yellow	1.5 ( .48 )
1818YLV	Zip	0	II	18x18 ( 457x457 )	Yellow	1.1 ( .48 )
1818YLVNV	Plain	0	II	18x18 ( 457x457 )	Yellow	1.1 ( .48 )
1836YLV	Zip	0	II	18x36 ( 457x914 )	Yellow	1.5 ( .68 )
1836YLVNV	Plain	0	II	18x36 ( 457x914 )	Yellow	1.5 ( .68 )
3636YLV	Zip	0	II	36x36 ( 914x914 )	Yellow	2.2 ( 1.0 )
3636YLVNV	Plain	0	II	36x36 ( 914x914 )	Yellow	2.2 ( 1.0 )

All blankets comply with current ASTM D1048 specifications.



Installing a Zip-On Blanket

## ROLL BLANKETS

Salisbury has gone to great lengths to protect workers from low voltage electrical hazards, by now offering insulating blanket material on a roll. Salisbury's insulating **Roll Blankets**, made from a high strength fabric reinforced Type II rubber, allow workers to custom-cut the blanket to fit each application at the job site. This minimizes the number of different low voltage blankets sizes and shapes that would otherwise need to be carries from job to job. Salisbury's insulating Type II rubber Roll Blankets, meets NEW ASTM F2320 standards.



- Convenient**
- Size Rolls**
- Flexible and Easy to Cut**
- Low Cost**
- Flame Resistant** - Self Extinguishing
- Type II** - Ozone and Ultra Violet Resistant
- Fabric Reinforced** - Puncture and Tear Resistant
- Flexible to -40°F**
- Highly Visible Colors**



Roll Blankets can be easily cut to size and fit for customized applications to each job.

Salisbury's Roll Blanket line includes a Class 1 (7,500v) **Clear PVC** material that permits complete visibility, yet provides the necessary insulating properties meeting ASTM F1742 standards.



All classes of Roll Blankets are easy to cut, and flexible to -40°F/C. Highly puncture and tear resistant, each class of blanket is also flame (self-extinguishing), oil, and ozone resistant. Each comes in a convenient 36" wide roll, 30 feet in length in unique colors making it easy to identify and highly visible in the work area.

Cat. No.	ASTM Class	Type	Size in. (mm)	Color	Weight ea. lbs. (kgs)
RLB00	00	II	3' x 30' (.9 x 9)	Maroon	20 (9)
RLB0	0	II	3' x 30' (.9 x 9)	Yellow	26 (11.8)
RLB1	1	II	3' x 30' (.9 x 9)	Yellow / Orange	36 (16.4)
RLBPVC1	1	-	3' x 30' (.9 x 9)	Clear	36 (16.4)

## BLANKET ACCESSORIES

### Clamp Pins

In addition to other uses in the utility industry, **Blanket Clamp Pins** can be effectively used to hold insulating blankets and rubber cover-up in place. Springs are used for tension while extra holes in the body of the pin are used to grip conductors and prevent line hose from sliding.

The New patent pending **22643 Blanket Pin Extension** allows for the worker to easily install or remove the blanket pin at a remote distance with the use of a shotgun stick

#### THE SALISBURY ADVANTAGE

##### Improved!

The Salisbury 21 blanket pin is more functional than ever. The new 21 pin has been improved to make it the most versatile pin on the market. Although the 21 pin always opened to accommodate just about any width needed, it has now been redesigned to open to a full 5 1/2 inches. That's the widest of any standard plastic pin in the industry. To accommodate application using a hot stick, the ends of the pin have been tapered to fit into the end of any brand clampstick. This allows the same 21 pin to be installed in line with the stick. For applications where a 90 degree angle of application and removal is necessary, the time proven HS21 pin fills the bill. Look for the new 21 pin to be supplied with your next pin order.

Blanket pins are made of fiberglass reinforced nylon or sliver-free hardwoods. Most pins have molded rubber tips to increase slip resistance.



Clamp Pins help line hose from slipping



20



25



26



YN20

#### ADVANTAGE



21

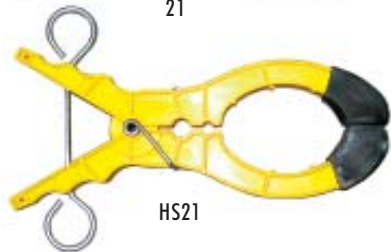

HS21



Salisbury 21 Blanket Pin



22643

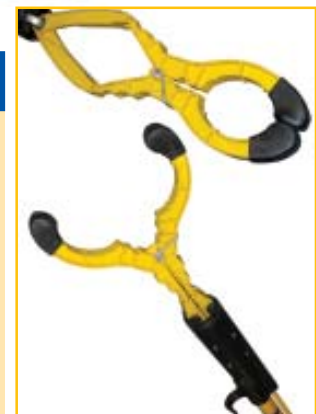

Salisbury 22643 Blanket Pin

Cat. No.	Description	Length in. ( mm )	Jaw Opening in. ( mm )	Weight ea. lbs. ( kgs )
20	Wood w/ pin boots	8.5 ( 216 )	4.75 ( 121 )	.33 ( .15 )
25	Wood w/o pin boots	7 ( 178 )	1.6 ( 41 )	.25 ( .11 )
26	Wood w/ pin boots	10 ( 254 )	7 ( 178 )	.5 ( .23 )
YN20	Wood w/ Sure grip	8.5 ( 216 )	4.75 ( 121 )	.33 ( .15 )
22643	Blanket pin extension	15.5	5.5	.37 ( .17 )
HS21	Nylon w/ pin boots	9.5 ( 241 )	5 ( 127 )	.37 ( .17 )
21	Nylon w/ pin boots	9.5 ( 241 )	5 ( 127 )	.37 ( .17 )

Optionally applied with Shotgun Stick

## BLANKET ACCESSORIES

### Fasteners

**Blanket Buttons** are designed to secure eyelet-style insulating blankets. The **B1** button, made of yellow plastic, snaps through the eyelet with thumb pressure on the large head. The bright orange polystyrene **B23** two-way buttons are inserted into the eyelets for use with a shotgun clamp stick or standard-duty switch stick.

**Magnetic Blanket Buttons** are designed for use in eyelets of insulating blankets when covering energized portions in hard-to-cover areas like pad mounts, cubicles, switchboards and substations. Four permanent floating magnets are mounted between nickel-plated steel plates. May be applied manually, wearing rubber gloves, or with a shot-gun stick.

**Ty-Straps** are 14" (356mm) and 30" (762mm) long and made of 1 1/2" (38mm) wide strips of rubber with hook and pile fasteners affixed to each end. The worker simply wraps the Ty-Strap around the positioned blanket and presses the hook and pile ends together. *Contact your local Salisbury representative for custom length Ty-Straps.*



B1



B23



MB6



TY14

Cat. No.	Description	Weight ea. lbs. ( kgs )
B1	Snap-Button, Orange	1 oz. ( .03 )
B23	Two-Way Button, Orange	1 oz. ( .03 )
MB6	Magnetic Blanket Button	7 oz. ( .2 )
TY14	Ty-Straps, 14" ( 356mm ) long	2 oz. ( .06 )
TY30	Ty-Straps, 30" ( 762mm ) long	4 oz. ( .12 )

## BLANKET ACCESSORIES

### Storage

**Blanket Canisters**—molded in bright orange, hi-impact polyethylene—protect insulating blankets when not in use. A tight-fitting cap is secured to the canister with polypropylene rope.

#### THE SALISBURY ADVANTAGE

*Salisbury's New P4H Blanket Canister revolutionizes the way you'll store your blankets.*

The new canister has a sturdier construction than the original P4, with integrated feet to keep the canister from rolling while being transported by truck or stored at the workplace. The new ergonomic handle runs the entire length of the canister, making lifting and carrying up to four 36 x 36" blankets much easier. Slots are provided within the canister to allow it to be secured in buckets or on trucks.

**Blanket Roll Ups** provide a safe and convenient means for protecting blankets from damage while in transport or storage. Ruggedly constructed of 12 oz. water resistant cotton duck with 12" side flaps to confine the blankets into position and prevent damage to the edges. Two heavy web straps with buckles close the roll-up, and a double web cross strap serves as a carrying handle.

**STORAGE TIPS:** *When more than one blanket is stored, the most convenient method of loading is to roll and insert each blanket into the canister independently. A single blanket can then be removed without removing the others. For maximum useful life, never fold, crease or compress insulating blankets while in storage.*



Cat. No.	Description	Fits Blanket Max Size in. (mm)	Dimensions in. (mm)	Capacity	Weight ea. lbs. (kgs)
P2	Canister	36 (914)	5 x 37 (127 x 940)	1-2 blankets	2 (.9)
P3	Canister	36 (914)	6 x 37 (152 x 940)	1-3 blankets	3 (1.4)
P4	Canister	36 (914)	7 x 37 (178 x 940)	1-4 blankets	3.5 (1.6)
P4H	Canister	36 (914)	7 x 37 (178 x 940)	1-4 blankets	3.5 (1.6)
P6	Canister	36 (914)	9 x 37 (229 x 940)	1-6 blankets	5 (2.3)
P3-47	Canister	46 (1168)	6 x 47 (152 x 1194)	1-2 blankets	4 (1.8)
22	Roll-up	22 (559)	41 x 33 (1041 x 838)	1-4 blankets	1.5 (.68)
36	Roll-up (cloth)	36 (914) or 46 (1168)	54 x 46 (1371 x 1168)	1-4 blankets	2.5 (1.1)
46	Roll-up (vinyl)	36 (914) or 46 (1168)	54 x 46 (1371 x 1168)	1-4 blankets	4 (1.8)

## SWITCHBOARD MATTING

**Switchboard Matting** is permanently placed in front of switchgear, motor control centers and other high voltage apparatus to provide personal protection for workers. It is also used when tending take-up and pay out reels and when adding or replacing conductors. Made from high quality Type II rubber, Class 2 matting is 1/4" (6.4mm) thick and is tested to 20kV, and Class 4 matting is 1/2" thick and tested to 40kV. Both Classes of matting comply with ASTM D178, Class 2 and Class 4 specifications. The corrugated surface acts as a safety tread while reducing the possibility of metal particles becoming embedded. Class 2 Switchboard matting is available in 25 yard rolls or custom cut to specified lengths, while Class 4 matting is sold in 20 yard rolls only.

Maximum Use AC Voltage Class 2, 17,000 volts, Class 4, 36000 volts.

**URD/Switchboard Blanket, 84" x 36"**, is ideal whenever a large insulating barrier is required to protect electrical workers from brush contact with live electrical apparatus. The URD has 10 eyelets and is made from red Type II SALCOR®, proof tested to 20 kV (or 30 kV for 367-3). The R96 canvas/roll-up carrier is recommended as a ground barrier when URD 367 is used outdoors.



Cat. No.	ASTM Class	Type	Size in. ( mm )	Weight ea. lbs. ( kgs )
<b>SWITCHBOARD MATTING</b>				
<b>M24-2</b>	2	II	1/4 x 24 ( 6 x 610 )	9 ( 4.1 )
<b>M30-2</b>	2	II	1/4 x 30 ( 6 x 762 )	12 ( 5.4 )
<b>M36-2</b>	2	II	1/4 x 36 ( 6 x 914 )	15 ( 6.8 )
<b>M48-2</b>	2	II	1/4 x 48 ( 6 x 1219 )	18 ( 8.2 )
<b>SWITCHBOARD MATTING</b>				
<b>M36-4*</b>	4	I	1/2 x 36" x 60 feet long ( 12 x 914 mm x 18.3 m long )	684 ( 307.8 )
All switchboard matting comply with current ASTM D178 standards				
*Sold in full rolls only.				
<b>URD BLANKET</b>				<b>Weight ea.</b>
<b>367</b>	2	II	84 x 36 ( 201.6 x 91.4 )	19 ( 41.8 )
<b>367-3</b>	3	II	84 x 36 ( 201.6 x 91.4 )	19 ( 41.8 )
<b>R96</b>	Carrier Canvas Roll-Up / Ground Barrier			3.5 ( 1.6 )



## ARC SUPPRESSION BLANKET

The **Arc Suppression Blanket** is used as a barrier for protection from the explosive and incendiary effects of electrical arcs and flashes. These hazardous electrical discharges can be caused by faults in cables, in cable splices and joints, and at transformer terminals, or they may be generated by the operation of switch gear, circuit breakers and lightning arrestors. The blanket can be used for worker protection in underground vaults, switchyards, and other locations where electrical equipment poses a risk of exposure to explosive electrical discharges. NOT an Insulating Blanket.



### CAUTION

Because of the unpredictability of electrical discharges, the Arc Suppression Blanket may not totally contain arcs and flashes, but only reduce or limit explosive and incendiary effects. In such cases, injuries may still occur, even when the blanket is properly used.



ARC48

Cat. No.	Dimensions in. ( mm )	Description	Weight ea. lbs. ( kgs )
ARC45	48 x 60 ( 1219 x 1524 )	w/ P4 Canister	7.5 ( 3.4 )
ARC48	48 x 96 ( 1219 x 2438 )	w/ P4 Canister	9 ( 4.1 )
21655	48 x 60 ( 1219 x 1524 )	Blanket Only	4.5 ( 2 )
21656	48 x 96 ( 1219 x 2438 )	Blanket Only	6 ( 2.7 )
P4	54 x 46 ( 1371 x 1168 )	Canister	3 ( 1.4 )

## INSULATING PLASTIC GUARDS & COVERS



## INSULATING PLASTIC GUARDS AND COVERS



**Guards and Covers** are intended for brush contact applications. All guards can be coupled together to cover any length required.

Guards and covers are available in three different grades: Grade 1 with hot stick handles attached for application and removal and Grade 2 with eye fittings for standard shotgun sticks and Grade 3 without eye fittings. Guards are designed to nest within each other for storage.

The guards and covers are made from two different orange thermoplastics: Type I is an ABS standard cold weather high impact plastic and Type III is an ABS/PVC weather resistant material that offers advantages in tensile and impact strength, hardness, UV stability, and flame resistance.

### ASTM F 968-93

Standard Specification for Electrically Insulating Plastic Guard Equipment for Protection of Workers<sup>A,B</sup>

**TABLE - A1.1 - WITHSTAND VOLTAGE PROOF TEST**

Class	Rating kV <sup>B</sup> Ø - Ø	Max Use 60 Hz Ø - Ground	Proof Test Withstand Voltage ( In-Service Testing )			Criteria
			Ø - Ground		Duration Minutes	
			60 Hz	DC		
2	14.6	8.4	13.0	18	1	No flashover other than momentary, as a result of too close spacing of electrodes
3	26.4	15.3	24	34	1	
4	36.6	21.1	32.0	45	1	
5	48.3	27.0	42.0	60	0.5	
6	72.5	41.8	64.0	91	0.25	

<sup>A</sup> Refer to Method A of Test Methods F 712.

<sup>B</sup> Cover-up materials are tested at values greater than the maximum use phase to ground values. The maximum use phase to phase values relate to guarded phase to guarded phase. The units are not rated for bare phase to guarded phase potentials.

**Pole Guards** are installed before setting new poles to guard against accidental line contact. They also guard against pole contacts by personnel working in insulating aerial buckets or on platforms. Pole Guards are made from orange, Type IABS, cold weather, high impact thermoplastic. Salisbury Pole Guards feature the unique Air Gap design. Uniformly spaced dimples minimize the amount of surface area contacting the pole. This provides added insulation to keep electrical leakage to a minimum. When two pole guards are used to cover longer lengths, the Air Gap dimples nest together “locking” the two together with ample overlap. **This is an exclusive feature to Salisbury Pole Guards.** The Air Gap design also allows for air flow between it and the pole minimizing moisture condensation and contamination buildup.

**SALISBURY ADVANTAGE**

*All Salisbury Pole Guards now come with bonded edge clips making installation and removal easier than ever.* The edge clip wraps around and is bonded to the edge of the guard putting the opening force just where it is needed most. This means the guard will open to its fullest with less effort than its drilled counterpart. Better than its previous "bonded" counterpart, the new clips hold stronger and are less likely to be damaged by forces encountered in storing.

Pole Guards should be used for brush contact. The opening should face away from possible line contacts, whenever possible. Pole Guards should be stored indoors to avoid prolonged exposure to UV rays and can be cleaned with a warm detergent solution.



2856

**NEW**



Bonded Handle



The 21936 Pole Guard includes cut-out to allow clearance for a line post insulator base which is mounted to a utility pole.

Cat. No.	Length ft. ( m )	Dia. in. ( mm )	Class	Weight ea. lbs. ( kgs )
2851	1' (.3)	6" (152.4)	4	3.3 (1.5)
2852	2' (.61)			6.3 (2.9)
2853	3' (.92)			9.0 (4.1)
2854	4' (1.2)			11.0 (5.0)
2856	6' (1.8)			17.0 (7.7)
1385	1' (.3)	9" (228.6)	5	3.6 (1.6)
1386	2' (.61)			7.0 (3.2)
1356	3' (.92)			10.0 (4.5)
1357	4' (1.2)			12.0 (5.4)
2496	6' (1.8)			19.0 (8.6)
2461	1' (.3)	12" (304.8)	5	5.0 (2.3)
2462	2' (.61)			8.0 (3.6)
2464	4' (1.2)			15.0 (6.8)
2466	6' (1.8)			22.0 (10.0)
21837	4' (1.2)	9" (228.6)	4 - FR Pole Guard	12.0 (5.4)
21936	2' (.61)	7" (177.8)	4	2.8 (1.27)

All guards are tested to ASTM F712 and are manufactured to ASTM F968 specifications

## VERSA® AND LINK® GUARDS

**Versa and Link Guards** make use of air as well as the dielectric strength of plastic to provide total insulating value. Both guards have a 7" diameter and a hook shaped inner lip to keep the guard in place.

**Versa Guards**, with a voltage rating of 36.6 kV\*, are designed so that two guards can be coupled together to cover most 13 kV single and double arm, pin and post constructions. A lighter 47" version (**2389**) of the standard 4.5' Versa Guard is available in a Type III ABS/PVC weather resistant material.

**Link Guards**, with a voltage rating of 72.5kV\*, have inner and outer shells that run full length to include male and female couple ends. Two guards connected provide four overlapping thicknesses of plastic plus air at a joint.

**Tee Connectors** are used on horizontal and vertical posts and suspension insulator strings when plastic line guards are used on the conductor. Made from Type I, ABS plastic with eye fittings, the connector accommodates the male end of a guard. Available in two ratings: 72.5 kV\* and 48.3 kV\*. Accepts 34.5 kV pin insulators along with post and insulator strings.

\*guarded Ø to guarded Ø.



Versa and Link Guard Cross Section



Cat. No.	Description	Type	ASTM Voltage Class	Grade	Weight ea. lbs. (kgs)
<b>VERSA GUARDS- 4.5' (1.37 m)</b>					
1686	ABS Eye	I	4	2	8.8 (4.0)
1687	ABS 4' Stick	I	4	1	10.8 (4.9)
1688	ABS 6' Stick	I	4	1	11.8 (5.4)
2373	ABS/PVC Eye	III	4	2	8.8 (4.0)
2377	ABS/PVC 4' Stick	III	4	1	10.8 (4.9)
2378	ABS/PVC 6' Stick	III	4	1	11.8 (5.4)
<b>VERSA GUARDS- 3.92' (1.19 m)</b>					
2389	ABS/PVC 4' Stick	III	4	1	6.1 (2.8)
2689	ABS/PVC Eye	III	4	2	8.1 (3.7)
<b>LINK GUARDS- 4.5' (1.37 m)</b>					
1680	ABS Eye	I	6	2	10.5 (4.8)
1681	ABS 4' Stick	I	6	1	12.5 (5.7)
1682	ABS 6' Stick	I	6	1	13.5 (6.1)
2475	ABS/PVC Eye	III	6	2	10.5 (4.8)
2476	ABS/PVC 4' Stick	III	6	1	12.5 (5.7)
2477	ABS/PVC 6' Stick	III	6	1	13.5 (6.1)
<b>TEE CONNECTORS</b>					
2224	69 kV	I	6	2	7.8 (3.5)
2884	46 kV	I	5	2	6.0 (2.7)

2884

Bags are available on page C-10.

All guards are tested to ASTM F712 and are manufactured to ASTM F968 specifications

# SALISBURY

Setting industry standards since 1855. 7520 N Long Ave Skokie IL 60077 Toll Free 877.406.4501 Fax 847.679.2401

## LIGHTWEIGHT CONDUCTOR COVERS

**Lightweight Conductor Covers** are ideal to cover long spans when weight is a consideration. They can be applied when wearing rubber gloves or with a fiberglass stick. Available with an eye for application with shotgun sticks. These covers have a voltage rating of 26.4 kV\*. The inside diameter is 2". This product can connect with Salisbury 1.5" I.D. Class 3 or 4 flexible cover-up equipment.

The **21826 Lightweight Conductor Cover** is a six (6', 1.8m) foot, cover rated Class 4 (36.6 kV\*). It is applied using rubber gloves when following appropriate company work rules. The inside diameter is 3" making it useful on a wide range of conductor sizes.

The unique "connector-stop" molded into one end prevents covers from overlapping during installation. This eliminates wasted time when trucks have to be moved to re-connect sections that did not couple correctly. This cover is also compatible with Salisbury 1.5" I.D. class 3 or 4 flexible rubber line hose.

All of our lightweight covers are made from safety orange Type I high density cross link polyethylene.

\*guarded Ø to guarded Ø.



Conductor Covers connect easily with either plastic or rubber line hose



21315



21172



21173



21234 Adapter Eye



21826



21826 Unique Connector Stop

Cat. No.	Description ft. ( m )	ASTM Voltage Class	Grade	Weight ea. lbs. ( kgs )
<b>27 kV CONDUCTOR COVERS</b>				
21172	5' ( 1.5 ) Cover w/ Eye	3	2	4.0 ( 1.8 )
21173	5' ( 1.5 ) Cover w/o Eye	3	--	3.0 ( 1.4 )
21315	5' ( 1.5 ) Cover w/ 4' ( 1.2 ) Fiberglass Stick	3	1	5.0 ( 2.25 )
21234	Adapter Eye	3	--	1.5 ( 0.7 )
<b>35kV CONDUCTOR COVER</b>				
21826	6' ( 1.8 ) Cover	4	--	3.0 ( 1.4 )

All guards are tested to ASTM F712 and are manufactured to ASTM F968 specifications

## CROSSARM GUARDS

**Crossarm Guards** are available in two different styles: the 1370 pin type and the 1371 post type. They are used to prevent tie wires from contacting crossarms during hot line operations. Two different tie downs are provided: a neoprene and a polypropylene rope. Both are secured in the slots provided in the eye fitting. The post type model has an automatic gap closer which covers the insulator slot opening over the end of the arm.

The **Slide-On Crossarm Guard 736PH** is applied by sliding the cover on to the arm from the end using the shotgun eye until the unit locks onto the insulator pins. The cover overlaps on top and has notches to ease application and removal.

Both of these guards are made from orange Type I ABS cold weather high impact plastic. These guards have a voltage rating of 36.6 kV\*.

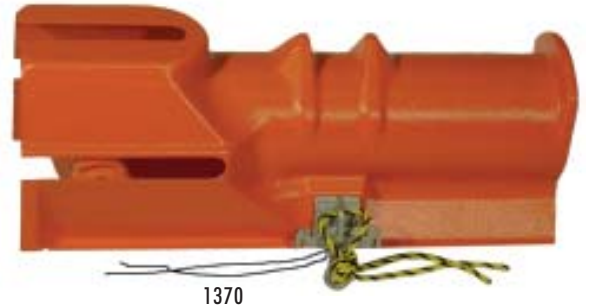

1370



1371

\*guarded Ø to guarded Ø.

Cat. No.	Description	Dimensions in. ( mm )	ASTM Voltage Class	Weight ea. lbs. ( kgs )
1370	Crossarm or Pin Type Guard	9 x 9 x 25.5 ( 229 x 229 x 648 )	4	5.7 ( 2.6 )
1371	Crossarm or Post Type Guard	Fits Crossarm: 5 x 6 ( 127 x 152 )	4	6.0 ( 2.7 )
736PH	Slide-On Crossarm Guard	7" I.D. x 36" ( 178 I.D. x 914 )	4	4.5 ( 2 )

All guards are tested to ASTM F712 and are manufactured to ASTM F968 specifications



736PH

## SUBSTATION COVER-UP

### Bus Guards

**Substation Cover-up** and barrier equipment is used during routine maintenance where accidental contact may occur. This barrier equipment is often used where outages are difficult to reach and the occurrence of accidental contact is high. These covers may be applied with rubber gloves or hot sticks. These covers are made from Type I orange ABS plastic. This equipment is not intended for permanent or semi-permanent barrier or insulating applications. Use these covers to protect against accidental contact only. These covers are not to be left installed for extended periods of time especially when in contact with both a grounded and energized object.

**Bus Guards** are easily interlocked with each other. To interlock units determine the length of bus to be covered. Place one unit on the bus then the other, pulling it over the first cover until the dimples interlock at the required length. This guard has a voltage rating of 36.6 kV\*.

**Bus “T” Guards** interlock two or three bus guards at bus tap “T” connections and 90 degree angles. To interlock units, first position the bus guard then slide the “T” guard over the top interlocking the dimples. This guard has a voltage rating of 36.6 kV\*.

**Bus End Guards** cover the ends of a substation bus supported by station post insulators. The slot and insulator grip hole can be easily enlarged in the field with a sharp knife. This cover also has a guide bead for a trim fit. This guard has a voltage rating of 26.4 kV\*.

Eye kit is available on page C-10.

\*guarded Ø to guarded Ø.

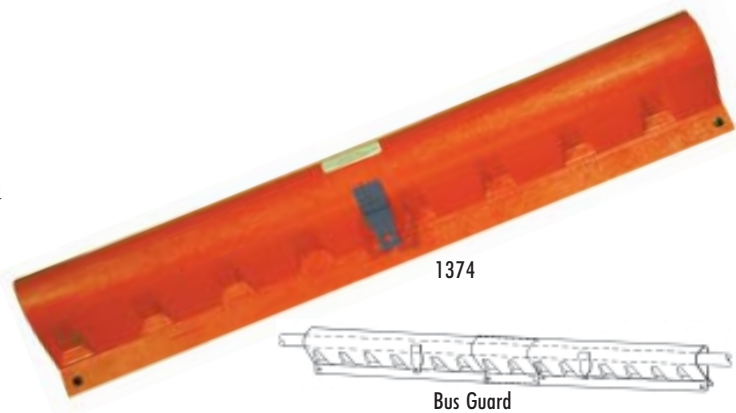

1374

Bus Guard



1375

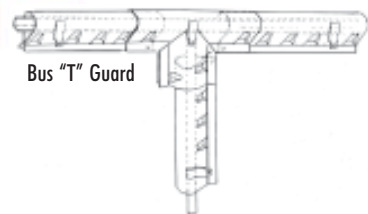

Bus “T” Guard



9992

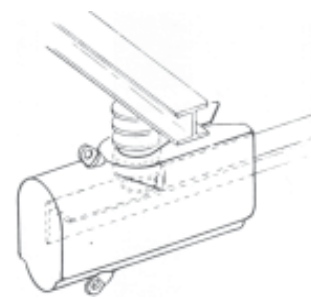

Bus End Guard

Cat. No.	Dimension in. ( mm )	Description	ASTM Voltage Class	Weight ea. lbs. ( kgs )
<b>Bus Guard</b>				
1374	5.25"x 9.5"x4.5' ( 133 x241x1.4m )	Impact Resistant	4	6.0 ( 2.7 )
<b>Bus “T” Guard</b>				
1375	5"x15"x25" ( 127x381 x635 )	ABS Plastic	4	4.0 ( 1.8 )
<b>Bus End Guard</b>				
9992	8.5"x12"x24" ( 216x305x610 )	UV Resistant High Density Cross Linked Polyethylene	3	5.0 ( 2.3 )

All guards are tested to ASTM F712 and are manufactured to ASTM F968 specifications



## SUBSTATION COVER-UP

### Switch Jaw Guard & Barrier

**Switch Jaw Guards** insulate the energized upper switch jaw and insulator when work is being done on the switch blade, lower insulator or other de-energized equipment ahead of the open switch. These guards easily slide over the upper insulator on open substation switches and lock over the bus. Jaw Guards are made from Type I UV resistant plastic. This guard has a voltage rating of 26.4 kV\*.



Barrier and Switch Jaw Guard installed on a Substation Switch.

The **24219 Switch Jaw Cover** provides an insulated barrier to the energized upper switch jaw and insulator, when work is being done on the switch blade, lower insulator, or other de-energized equipment ahead of the open switch. This guard slides easily over the upper insulator on open substation neutral disconnect cabinet switches and locks over the bus. The 24219 Cover is made from Type I cold weather high impact plastic. This guard has a voltage rating of 14.6 kV\*.



The **T1, Terminal Sleeve Disconnect Switch** is used on open style disconnects and made from Type II SALCOR®, EPDM rubber.

**Switch Barriers** slide between the last two skirts on the post or pin cap insulators of the substation disconnect switch. This locks the barrier in place. When switches are mounted back to back and work is needed on one, the barrier can be placed on the energized switch to form a visible, electrical and mechanical barrier. Work can then be done on the opposite switch or other de-energized equipment. This guard has a voltage rating of 36.6 kV\*.



\*guarded Ø to guarded Ø.

NOTE: If your substation needs are not fulfilled by the products on this page, please contact your local Salisbury representative for custom applications.

Cat. No.	Dimensions in. (mm)	Description	ASTM Voltage Class	Weight ea. lbs. (kgs)
<b>JAW GUARD</b>				
2418	8" D. x 18" ( 203 D. x 457 )	Use w/ switch 8"(203) Dia.	3	4 ( 1.8 )
2424	8" D. x 24" ( 203 D. x 610 )	Insulated	3	5 ( 2.3 )
24455	8" D. x 16" ( 203 D. x 406 )		3	2.25 ( 1.14 )
2413	13" D. x 24" ( 330 D. x 610 )	Use w/ switch 13"(330) Dia. Pin Cap Insulators	3	7 ( 3.2 )
<b>JAW COVER &amp; TERMINAL SLEEVE</b>				
24219		Jaw Cover	2	4 ( 1.8 )
T1	10" x 2" I.D. ( 254 x 51 I.D. )	Terminal Sleeve		.33 ( .15 )
<b>BARRIER</b>				
1376	.125"x43"x52" ( 3.2x1092x1320 ) 5" ( 127 ) slot to center	Orange Type I High Impact ABS Plastic	4	12 ( 5.5 )

# SALISBURY

Setting industry standards since 1855. 7520 N Long Ave Skokie IL 60077 Toll Free 877.406.4501 Fax 847.679.2401

## GUARD AND COVER ACCESSORIES

**Bags for Line Guards and Pole Guards** come in two different sizes and can hold two nested line guards.

The 1871 **Pole Guard Bag** is designed to hold two nested pole guards.

All of these bags are made from soil resistant vinyl coated nylon and equipped with a drawstring and mail bag lock.

The **Applicator Eye Kit** is used to apply a new or extra shotgun eye where needed. If a Bus or “T” guard needs to be shortened or inverted, this kit allows modifications to be made. Clear PVC pipe cement may be used to secure the eye. Directions are included.

The **Insulating Barrier Sheet** can be used to create barriers in the field. This sheet is made from Type I ABS plastic and can be worked with ordinary hand tools, saws, tin snips and drills. It can also be hot formed using a heat gun. For example, this sheet can be bent at right angles over a table top to produce flanges for joining with other parts. Pipe adhesive can be used to join to other parts. The rated puncture is 50kV. This sheet is not intended for permanent or semi-permanent barrier or insulating applications. It should be used for accidental brush applications. Meets ASTM F712 and F968.



Cat. No.	Dimensions ft. ( m ) in. ( mm )	Weight ea. lbs. ( kgs )
<b>BAGS - LINE GUARDS</b>		
1933	2 - 4.5' ( 1.4 ) line guards or 2 - 9' x 4' ( 229 x 1.22 ) Line Guards	3.5 ( 1.6 )
1841	2 - 6' ( 1.8 ) line guards or 2 - 9' x 6' ( 229 x 1.8 ) Line Guards	4.5 ( 2.0 )
<b>BAGS - POLE GUARDS</b>		
1871	2 - 12' x 6' ( 305 x 1.8 ) Pole Guards	5.2 ( 2.4 )
<b>EYE KIT</b>		
1378	2 eyes per kit	.25 ( .11 )
<b>BARRIER SHEET</b>		
2842	4' x 8' x .125" ( 1.2m x 2.4m x 3.2 )	36 ( 16.4 )

## GUARD AND COVER ACCESSORIES

The **Universal Hot Cover** is used to provide additional cover-up and clearances. This cover is made from orange Type I polyethylene plastic. The hot stick eye allows this cover to be placed and removed with a shotgun type clamp stick or with rubber gloves. To secure in place use the elastic tie-down cord. This cover can be used on overhead or underground energized cable terminators, potheads or while inverted, on lightning arrestors. This cover has a voltage rating of 26.4 kV\*.

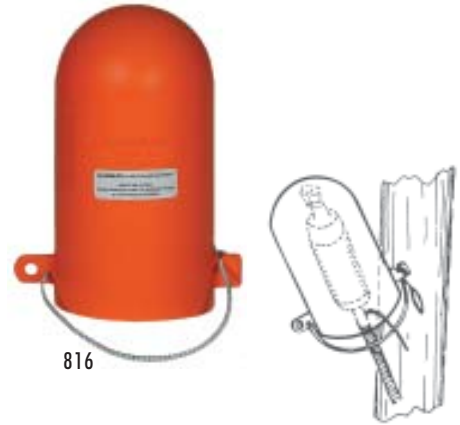

The **Pole Bracket and Insulator Base Cover** guards against accidental contact with pole, bracket and insulator base during routine maintenance. It is made from an orange UV resistant Type I polyethylene plastic. The Grade 2 hot stick eye allows this cover to be applied and removed with a hot stick or with rubber gloves. It covers metal or fiberglass brackets 8-12" long and pole mounting plates. This cover also interlocks with a pole insulator. This cover has a voltage rating of 26.4 kV\*.

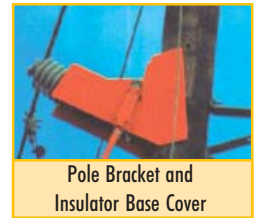

The **Underground Distribution Elbow Cover** covers primary elbows and spade terminals during routine maintenance. It covers up to the face plate and cable connection. This cover is made from orange Type I polyethylene plastic. The hot stick eye allows this cover to be applied and removed with a hot stick. This cover self locks for a secure fit in confined areas. The bead can be trimmed in the field to meet clearance requirements. This cover has a voltage rating of 26.4 kV\*.



\*guarded Ø to guarded Ø .

Cat. No.	Description	ASTM Voltage Class	Weight ea. lbs. ( kgs )
816	Hot Cover 8" x 16" ( 203 x 406 )	3	2.5 ( 1.1 )
4333	Pole Bracket & Insulator Base Cover 20" x 25" ( 508 x 635 )	3	2.5 ( 1.1 )
4314	Underground Distribution Elbow Cover 15" x 14.25" ( 381 x 362 )	3	2.0 ( .9 )

All guards are tested to ASTM F712 and are manufactured to ASTM F968 specifications

# SALISBURY

Setting industry standards since 1855. 7520 N Long Ave Skokie IL 60077 Toll Free 877.406.4501 Fax 847.679.2401

**OUTAGE PROTECTION**



## SILICONE BUSHING COVERS

**Standard Salisbury Bushing Covers** and **Salisbury Tri-Port Bushing Covers** are made from Ozone and UV resistant *silicone* rubber, maximizing the outdoor durability and tracking resistance. **These covers have been accepted by Rural Utilities Service (RUS).**

Bushing Covers protect against wildlife contacts between energized equipment and ground by insulating exposed energized bushing parts.

**Standard** and **Tri-Port Bushing Covers** interlock with the top weathershed of the bushing and are securely fastened by inserting lock buttons (provided). The **21116TC, Standard Bushing Cover**, includes the **21644 Tube Closure**. The 21644 Tube Closure provides an easier and quicker way to securely close the standard bushing cover.

Bushing Covers can be installed without disconnecting equipment using rubber insulating gloves. Covering a small area of the lead wire, the opening can be trimmed to accommodate larger wires or 5/8" and 3/4" Salisbury Stinger Covers.

### Cone Bushing Covers

For complete 360 degree coverage, the BC512 is the right choice. Complete with upper and lower trim rings for a custom fit size and internal ribs for added air flow and water drainage. Made from Ozone and UV resistant *silicone* rubber, the BC512 permanently protects bushings from all sources of potential outages. Installation requires de-energizing equipment.



21116 - Standard

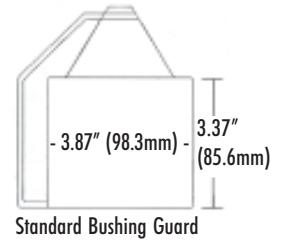

21116 TC- Standard



21644



21317 - Tri-Port

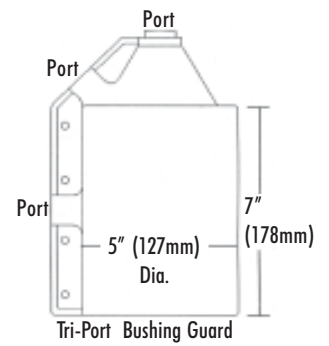

BC512

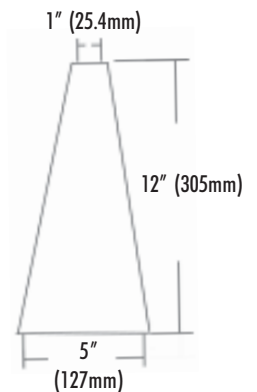

Cat. No.	Description	Dimensions in. ( mm )	Quantity	Flashover Test Voltage	Weight ea. lbs. ( kgs )
<b>BUSHING COVERS</b>					
21116	Cover Only	-	24 pcs.	16 kV	16 ( 7.3 )
21116TC	Cover Only w/ 21644	-	24 pcs.	16 kV	16 ( 7.3 )
21644	Tube Closure	-	-	-	-
21183	Cover Kit w/Stinger Cover*	.375 x 18 ( 9.5 x 457 )	24pcs.	n/a	20 ( 9 )
BC512	Cone Bushing Cover	12H x 5 W ( 305 H x 127 W )	1	n/a	1.5 ( .7 )
<b>TRI-PORT BUSHING COVERS</b>					
21317	Cover Only		24 pcs.	16 kV	28 ( 12.7 )
24140	Cover Kit w/ Stinger Cover*	3/8 x 18 ( 9.5 x 457 )	24 pcs.	n/a	35 ( 16 )

\* See page D-4 for more Stinger Covers

**SALISBURY**

Setting industry standards since 1855. 7520 N Long Ave Skokie IL 60077 Toll Free 877.406.4501 Fax 847.679.2401

## STINGER COVERS

**Stinger Covers** protect against phase to phase and phase to ground wildlife contacts. **These covers have been accepted by Rural Utilities Service (RUS).**

The stinger cover can be installed without disconnecting the lead wire from the bushing. Available in three diameters, it is easily cut in the field to the needed length.

Stinger covers are track resistant and made from Ozone and UV resistant SALCOR® elastomer in a grey color. The covers are proven to provide years of reliable service either independently or when used with bushing covers.



Stinger Cover Cross-Section



38-50SC

Cat. No.	I.D. in. ( mm )	Dimensions ft. ( m )	Quantity	Flashover Test Voltage kV	Weight lbs. ( kgs )
<b>EPDM</b>					
38-2SC	3/8 ( 9.5 )	2 ( .61 )	25 pcs.	13	9.5 ( 4.3 )
38-50SC	3/8 ( 9.5 )	50 ( 15.3 )	1 coil	13	9.5 ( 4.3 )
38-12SC	3/8 ( 9.5 )	12 ( 3.7 )	4 pcs.	13	9.5 ( 4.3 )
38-18SC	3/8 ( 9.5 )	18" ( 457mm )	50 pcs.	13	11 ( 5 )
38-100SC	3/8 ( 9.5 )	100 ( 30.5 )	1 coil	13	16 ( 7.25 )
58-12SC	5/8 ( 15.9 )	12 ( 3.7 ) coil	4 pcs.	18	22 ( 10 )
58-50SC	5/8 ( 15.9 )	50 ( 15.3 ) coil	1 pc.	18	21 ( 9.5 )
58-100SC	5/8 ( 15.9 )	100 ( 30.5 ) coil	1 pc.	18	45 ( 20.5 )
34-12SC	3/4 ( 25.4 )	12 ( 3.7 ) coil	4 pcs.	20.5	22 ( 10 )
34-25SC	3/4 ( 25.4 )	25 ( 7.6 ) coil	2 pc.	20.5	22 ( 10 )

For sizes and lengths other than those listed above, contact your local Salisbury representative.

## INSTANT INSULATION

**Instant Insulation** may be installed as permanent cover to protect against outages caused by weather, trees and animals. Instant Insulation resists ozone and ultraviolet deterioration while remaining flexible even at sub-zero conditions.

Instant Insulation is made of orange or grey SALCOR® elastomer. Instant Insulation is sold in three diameters, each 12 feet in length. Each include six nylon UV resistant bar-lock cable ties to secure it to the conductor.

Instant Insulation can be installed using the **2494 Applicator**. To install, insert one end of the Instant Insulation into the applicator prongs, then roll and coil the insulation as shown. Secure the coil end with tape, cable ties, or rubber bands. To install, release the secured end and the Instant Insulation will unroll and enclose the conductor.

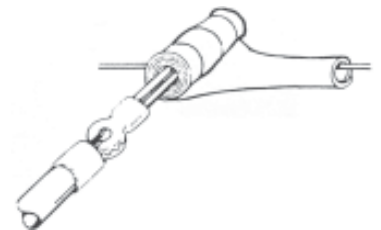
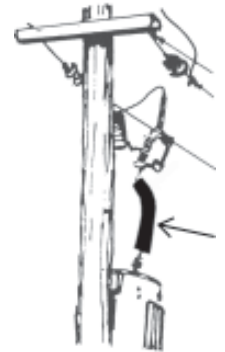

Cat No.	Dimensions		Color	Weight ea.	
	in.	mm		lbs.	kgs
<b>INSTANT INSULATION 12' / 3.6m long</b>					
1127	.75 I.D.	19 I.D.	Grey	7	3.2
1128	.75 I.D.	19 I.D.	Orange	7	3.2
1129	1.00 I.D.	25 I.D.	Grey	8	3.6
1130	1.00 I.D.	25 I.D.	Orange	8	3.6
1131	1.25 I.D.	32 I.D.	Grey	10	4.5
1132	1.25 I.D.	32 I.D.	Orange	10	4.5
2494	Universal Hot Stick Applicator			1	.5

**NEW TRIANGLE ANTI-PERCH**

The **Triangle Anti-Perch** is designed to discourage raptors from perching on crossarms, risking electrocution by phase to phase or phase to ground contact. The unique “third leg” is designed to discourage smaller raptors, such as hawks, from attempting to perch inside the Triangle. The 21907 fits standard 3.5" (nominal) width crossarms. All necessary mounting hardware is included with the 21907.



The Triangle Anti-Perch incorporates dielectric U.L. rated schedule 40 PVC piping and the base is resistant to the effects of UV, ozone and fire.

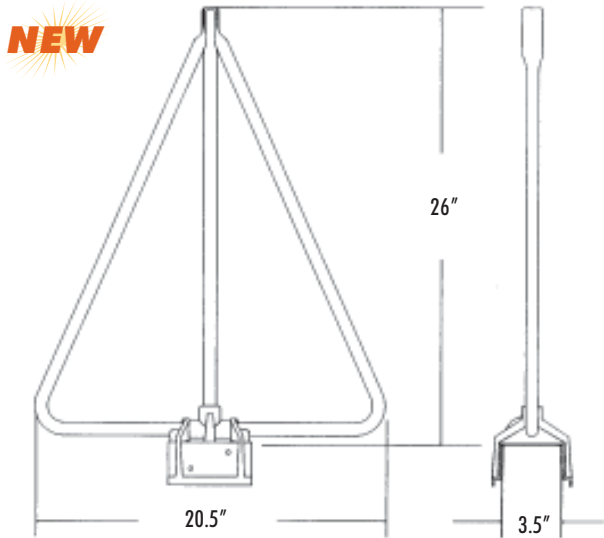

Cat No.	Description	Coverage Width	Weight ea.	
			lbs.	kgs
21907	Triangle Anti-Perch	20.5"	1.5	.69



## NEW THREE PIECE BIRDCUARD

The 3 phase single crossarm structure with a lowered neutral is another frequent perch for hunting birds. Installation of the **Birdguard** series, with a material dielectric strength of 72 kV, is a cost-effective way of creating a safe landing for eagles and other protected species. Using the three piece Birdguard protects the center phase conductor, therefore increasing the spacing between the energized, uninsulated conductors to 88 inches. **These covers have been accepted by Rural Utilities Service (RUS).**



**NEW**



21909

The Salisbury Birdguard system consists of two different sized insulator covers. The 21909 and 21910 are designed to fit a variety of ANSI class insulators, the chart below can assist in selecting the proper cover for your application. The covers have been designed to snap over the insulator and conductor while energized. The Birdguard has an eye on the top for application with a shotgun stick and two extension arms. Three detents for on-site conductor sizing allow the lineman to hacksaw cut the arm for an exact fit. A two-man crew can install the Birdguard in approximately two minutes per unit. The system will need to be fully assembled prior to installation.



21910

Cat No.	Insulator Class	Weight ea.	
		lbs.	kgs
21909	55-5; 55-6; 56-1, 2, 3, 4, 5; 57-12, 13, 14, 15	4.18	1.9
21910	55-2, 3, 4; 57-1, 11	3.6	1.6

# NEW ARRESTOR AND BUSHING CAPS

Recent studies show over 60% of raptor electrocutions occur on poles with equipment such as cutouts, transformers, reclosers, and surge arresters mounted on the pole. **Both the Transformer Bushing Cap and Surge Arrester Caps have a material dielectric strength that exceeds 72kV and is accepted by RUS.** All of the Caps are manufactured with UV, ozone and fire resistant material.

**Salisbury's Surge Arrester Caps** are designed to snap over the first "shed" or "skirt" of the arrester, as well as fit down snugly over the wire.

The **Salisbury 21901 Transformer Bushing Cap** is designed to snap over the first "shed" or "skirt" of the bushing, thereby insuring proper installation and preventing the cover from "walking" up the jumper.

In addition to the use of the products shown here, Salisbury recommends the use of Stinger Covers (available on page 4), when installing these devices for maximum outage protection.



21901

**NEW**



21902



21904



21903

Cat No.	Description	Weight ea.	
		lbs.	kgs
21901	Transformer Bushing Cap	.19	.085
21902	Polymer Arrester Cap	.14	.062
21903	Ceramic Arrester Cap	.11	.051
21904	Polymer Arrester Cap for Flipper Fuse	.19	.085
21908	Polymer Arrester Cover for use with Primary Tap	.20	.091

## **NEW CUTOUT SWITCH COVER**

**Switch Covers** are designed to fit over the connection and exposed upper metal bracket on the cutouts, without interfering with the normal operation of the unit. These covers are manufactured from UV, ozone and fire resistant material.

All **Salisbury Cutout Switch Covers** have a material dielectric strength that exceeds 72kV.

Salisbury recommends the use of **Stinger Covers** (available on page 4), when installing these devices for maximum outage protection.



**NEW**



21905

21899 and 21900



Cat No.	Description	Weight ea.	
		lbs.	kgs
21899	Fused Cutout Switch for ABB-Chance-Cooper switches	.4	.184
21900	Fused Cutout Switch Cover - for S&C switches	.3	.139
21905	Loadbreak Switch Cover	.95	.431
27022	Fused Cutout Switch Cover for 200 A S & C	.4	.184
27004	Fused Cutout Switch Cover for Maurizo	.4	.184
27031	Fused Cutout Switch Cover for Kearny "HX"	.3	.139
27036	Fused Cutout Switch Cover for old style ABB/NCX	.4	.184
27044	Fused Cutout Switch Cover for PLH	.4	.184

**SALISBURY**

Setting industry standards since 1855. 7520 N Long Ave Skokie IL 60077 Toll Free 877.406.4501 Fax 847.679.2401

# NEW WOOD POLE CAP

The Wood Pole Cap is designed for installation on an overhead conductor wood pole. It used to discourage birds from perching on the pole tops and eliminating the simultaneous contact of the energized overhead conductor and the grounded hardware on the ridge pin support. The base diameter is 8.0”.

**NEW**

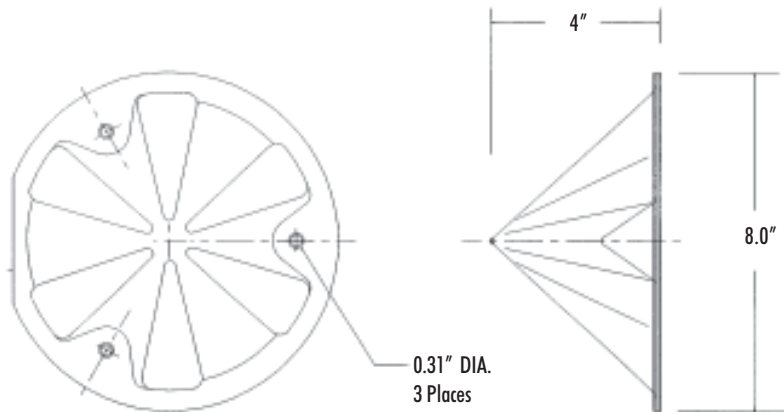
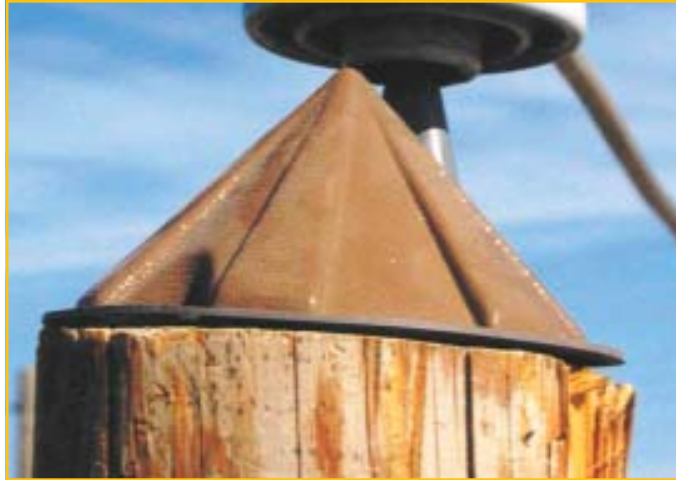

Cat No.	Description	Weight ea.	
		lbs.	kgs
21906	Wood Pole Cap	.3	.136

## GLOVES & SLEEVES



USE SALISBURY EXCLUSIVE  
SMOOTH COMFORT GLOVES



## ASTM Chart

### Rubber and SALCOR® Protective Equipment

Rubber insulating gloves are available in six ASTM defined voltage classes. Rubber insulating sleeves are available in Class 0 through 4. The chart below identifies the class, proof test voltage and maximum allowable exposure voltage.

For an 8 x 10 reprint of this chart, contact your local Salisbury representative.

#### ASTM Labeling Chart

for Salisbury Linemen's Natural Rubber and SALCOR® Rubber Protective Equipment

Class Color	Proof Test Voltage AC / DC	Max. Use Voltage AC / DC	Rubber Molded Products Label	Glove Label	Rubber Dipped Sleeve Label
00 Beige	2500 / 10,000	500 / 750			
0 Red	5,000 / 20,000	1,000 / 1,500			
1 White	10,000 / 40,000	7,500 / 11,250			
2 Yellow	20,000 / 50,000	17,000 / 25,500			
3 Green	30,000 / 60,000	26,500 / 39,750			
4 Orange	40,000 / 70,000	36,000 / 54,000			

Insulating Gloves and Sleeves must have a color coded label to meet appropriate ASTM Specifications.

Gloves and Sleeves must have a color coded label.



"Suitable for live working."  
IEC60903:2002 & IEC60417 fig. 5216

***Manufactured for  
outstanding protection,  
comfort and long-life***

Rubber insulating gloves are among the most important articles of personal protection for electrical workers. Incorporating high dielectric and physical strength, flexibility and durability, Salisbury rubber insulating gloves have earned the reputation for superior performance—meeting and exceeding the requirements of current ASTM D120 specifications and IEC EN60903 Standards.

Salisbury rubber insulating gloves are manufactured by dipping porcelain forms into a tank of liquefied rubber. The thin layer of rubber which results is allowed to dry and the process is repeated until the required thickness is reached. Depending on the voltage class of the glove, this dipping-drying-dipping cycle may need to be repeated over 30 times. After the desired thickness is achieved, the gloves are allowed to dry. Once dry, they are cut to length, the reinforcing bead is rolled, and the ASTM label and manufacturing information is applied along with any additional permanent marking that may be requested.

The gloves are cured in an autoclave under steam pressure and heat. After curing, the gloves are visually inspected. Gloves with visual imperfections are rejected. The gloves are then given a halogenation treatment (chlorination) to increase the comfort and wearability. The gloves are electrically tested following ASTM D120/IEC 903 specifications. Following the electrical test, the gloves are given a final visual inspection. The gloves are then ready to be boxed and shipped.



### **ARE YOU NOT SURE WHAT GLOVES YOU NEED?**

***Salisbury has made it easy  
with the Salisbury Glove Configurator™***

#### **Glove Configurator**

Visit [www.whsalisbury.com/glove\\_configurator/](http://www.whsalisbury.com/glove_configurator/) to use Salisbury's exclusive Glove Configurator™. This interactive web tool allows you to easily determine which Salisbury gloves you need to meet your requirements.



## MAKING A PROPER INSPECTION

OSHA 1910.137 states “Insulating equipment shall be inspected before each day’s use and immediately following any incident that can reasonably be suspected of having caused damage. Insulating gloves shall be given an air test, along with the inspection.” Salisbury’s New **G100** (Patent Pending), with **G100A adapter for Class 00 and 0** and smaller size gloves, and the **G99**, without additional adapter, are the perfect answer for inflating your gloves for inspection.

The **G99** is a simple, easy to use, portable glove inflator. The G99 provides a quality means of inspecting gloves in the field. The glove is secured to the inflator using a nylon strap and fastened with a hook and pile closure. Inflation is accomplished by pumping the bellows of the inflator against any surface. **NOTE: gloves should be expanded no more than 1.5 times their normal size for Type I, and 1.25 times normal for Type II SALCOR.**

### SALISBURY ADVANTAGE

The **G100** is also a simple and easy to use, portable glove inflator. The G100 operates exactly like the G99, but includes an additional **G100A** adapter to also inspect Class 00 and 0 and smaller gloves. To use the adapter, the glove is secured to the G100A adapter using a nylon strap with a hook and pile closure. The adapter, with glove attached, is then placed on top of the inflator to be inflated for inspection.

In the test lab or service center, the **G1** and **G2** glove inflators are preferred. Both can be pneumatically operated, large quantities of gloves can be inspected in minimal time. The G1 is pedestal mounted and does not require connection to a source of compressed air. The G1 provides maximum efficiency for testing large quantities of gloves.

The **G2** bench mounted inflator is ideal for smaller quantities of gloves. This inflator can either be pneumatically operated or by a built in hand pump.

Cat. No.	Description	Weight ea. lbs. ( mm )
G99	Glove Inflator Kit	2 ( .91 )
G99B	Replacement Bag	-
G99S	Replacement Strap	-
G99V	Replacement Check Valve	-
G1	Pedestal w/ Foot Control	45 ( 20.4 )
G2	Bench Type w/ Hand Pump	40 ( 18.1 )
G100	Glove Inflator Kit w/ Adapter	-
G100A	Lo-Volt Glove Adapter	-



G99



G100



G100A



G100 with inflated lo-volt glove ready for inspection.



G1



G2 with inflated glove ready for inspection.



## SALISBURY LINEMEN'S GLOVES

Low Voltage - ASTM Class 00, 0



Measure the circumference around the palm.

### Selecting the right size, length and style

Salisbury linemen's gloves are available in a full range of sizes, from 7,8 through 12, including half sizes. Proper fit is important. To determine glove size, measure the circumference around the palm. Allow for additional room if fabric glove liners are to be worn, especially with thermal liners.

### SALISBURY ADVANTAGE

Type I and Type II gloves are extremely flexible to make working with small parts easy. The gloves meet or exceed ASTM D120 and IEC EN60903 Standards.

Class 00 and 0 gloves are available in 11 and 14 inch lengths. **Class 00 Electrical Insulating Rubber Gloves** are made from red or black Type I natural rubber, blue Type II SALCOR®, or in contrasting blue/orange Type II SALCOR. The contrast between the outer orange color against the inner blue color makes inspecting for cuts and tears easier when the glove is inflated or stretched.

**Class 0 Electrical Insulating Rubber Gloves** are available in red, black, yellow, and contrasting black/yellow colors in Type I Natural Rubber. The contrast between the outer yellow color against the inner black color makes inspecting for cuts and tears easier when the glove is inflated or stretched. These gloves are also available in blue or contrasting blue/orange colors Type II SALCOR rubber.

#### Cat. No. Breakdown for Class 00 Gloves

Class	Length	Color	Size
E 00	11	R, B, BL, or BLO	7, 8, 8H 9, 9H
E 00	14	R, B, BL, or BLO	10, 10H 11, 11H 12
R=red B=black Type I Natural Rubber BL=blue BLO=blue in, orange out : Type II SALCOR			
Example: E0011BL/8			

#### Cat. No. Breakdown for Class 0 Gloves

Class	Length	Color	Size
E 0	11	Y, B, R, BL, BLO, or BY	7, 8, 8H 9, 9H
E 0	14	Y, B, R, BL, BLO, or BY	10, 10H 11, 11H 12
R=red B=black Y=yellow: Type I Natural Rubber BY=black in, yellow out: Type I Natural Rubber BL=blue BLO=blue in, orange out : Type II SALCOR			
Example: E014R/9			



E011Y Gloves being manufactured.



E0011BL/9



E0014BLO/9



E011R/9



E011Y/10

# SALISBURY

Setting industry standards since 1855. 7520 N Long Ave Skokie IL 60077 Toll Free 877.406.4501 Fax 847.679.2401

# SALISBURY LINEMEN'S GLOVES

## High Voltage - ASTM Class 1, 2, 3, 4

Class 1 through 4 gloves are available in the industry standard color black, or in contrasting two-color combinations. The contrast between the thin outer color against the inner color makes inspecting for cuts and tears easier when the glove is inflated or stretched.

Class 1 through 4 gloves are available in 14, 16 and 18 inch lengths. A **straight cuff** is standard on 14" (356 mm), 16" (406 mm) & 18" (457 mm) gloves. The straight cuff is the default style.

A **contour cuff** is angled to prevent bunching or binding at the elbow when the arm is bent. Available on all 18" (457mm) gloves only.

The **bell cuff** and **flare cuff**, accommodate heavier winter clothing and allow for greater air flow in warmer weather. These are available for Class 1 through 4 gloves. Bell and flare cuff gloves are not available in sizes 7, 8 or 8H.



### Cat. No. Breakdown for Class 1,2,3,4 Gloves

Class	Glove Length in.	Cuff Style***	Color	Size
E 1	14, 16 or 18	FC, BC, C	B, YB or RB	7, 8, 8H
E 2	14, 16 or 18	FC, BC, C	B, YB or RB	9,9H
E 3*	14, 16 or 18	FC, BC, C	B, YB or RB	10, 10H
E 4**	14, 16 or 18	FC, BC, C	B, YB or RB	11, 11H
				12

FC=flare cuff BC=bell cuff C=contour cuff

\*available in sizes 8 through 12 including half sizes only

\*\*available in sizes 9 through 12 including half sizes only

B=black YB=Y inside, B out RB=R inside, B out: Type I Natural Rubber

Example: E116FCYB/10

\*\*\* flare cuff gloves available in sizes 8H through 12 including half sizes only

\*\*\* bell cuff gloves available in sizes 9 through 12 including half sizes only

## **SALISBURY LINEMEN'S MITTENS**

### **High Voltage - ASTM Class 1, 2, 3, 4**

**Salisbury Lineman's Mittens** are made from the same durable, lightweight rubber as the five finger gloves yet keep the user warmer during harsh temperatures. The three finger mitten allows for precise hand movement as well.

Class 1 through 4 mittens are available in the industry standard black or in contrasting two-color combinations. The contrast between the thin outer color against the inner color makes inspecting for cuts and tears easier when the glove is inflated or stretched.

Class 1 through Class 4 mittens are available in 14, 16 and 18 inch lengths. A **bell cuff** design is standard on all mittens. BC= Bell Cuff.

Mittens are available in sizes 9, through 11 full sizes only.



EM216BCRB/11

<b>Cat. No. Breakdown for Class 1,2,3,4 Gloves</b>				
Class	Glove Length in.	Cuff Style	Color	Size
EM 1	14, 16 or 18	BC	B, YB or RB	9
EM 2	14, 16 or 18	BC	B, YB or RB	10
EM 3	14, 16 or 18	BC	B, YB or RB	11
EM 4	14, 16 or 18	BC	B, YB or RB	
Bell Cuff colors B=black YB=Yellow inside, Black out RB=Red inside, Black out				

# LEATHER PROTECTORS

**Leather Protector Gloves** should always be worn over Rubber Insulating Gloves to provide the needed mechanical protection against cuts, abrasions and punctures. All Salisbury protectors are steamed pressed on curved hand forms to insure proper fit over Rubber Gloves. Manufactured from top grade leather, all are sewn with heavy duty nylon thread in the “gunn cut” inseam construction pattern. Each protector for Class 1-4 gloves are equipped with a nonmetallic buckle on the pull strap and an extra wide leather reinforcement over the thumb seam. Protectors for Class 00 and 0 gloves are available with non-metallic buckle and pull strap or elastic wrist.



**All Salisbury Leather Protectors meet ASTM F696 standards.**

It is the responsibility of the purchaser to specify the overall length of the protector gloves. The Clearance Table shows the minimum distance which shall be allowed between the protector glove cuff and the bead of the rubber glove per ASTM F496 Specifications.

**WARNING: Do not use leather protectors alone for protection against electric shock. Serious injury or death will result. Always use proper rubber insulating gloves.**

Proper care of leather protectors is essential to user safety. Inspect the leather protectors when inspecting rubber gloves. Metal particles, imbedded wire, abrasive materials or any substance that could physically damage the rubber gloves must be removed from the protector before use.



CLEARANCE TABLE FOR LEATHER PROTECTORS PER ASTM F496		
Glove Class	Min. Distance Between Protectors and Rubber Gloves	
	in.	mm
00, 0	1/2	13
1	1	25
2	2	51
3	3	76
4	4	102

Minimum Distance from Protector and Rubber Glove	Glove Class	Leather Protector Cuff
		----- Cuff Line -----
	00, 0	1/2" from cuff
	1	1" from cuff
	2	2" from cuff
	3	3" from cuff
	4	4" from cuff

## PREMIUM LEATHER PROTECTORS

### SALISBURY ADVANTAGE

#### 156 Premium Series

*Salisbury's SALCOR® cuff provides maximum protection.*

These protectors are made from specially tanned Grade A Red Boulevard buffed leather and an orange colored SALCOR “Super Cuff” in the 4” (102 mm) and 6” (152 mm) cuff lengths. The “Super Cuff” has better characteristics than leather or vinyl cuffs; it does not absorb water, has greater track resistance, and creepage.

Cat. No.	Cuff Length in. ( mm )	OAL Length in. ( mm )	Weight ea. lbs. ( kgs )
156-4	4 (102) Straight Cuff	12 (305)	1 (.5)
156-6	6 (152) Straight Cuff	14 (356)	1.2 (.5)

Available in dual sizes: 8/8.5, 9/9.5, 10/10.5, 11/11.5, 12



156-6

#### 103 Mitten Protector

Three finger mitten protectors provide mechanical protection for lineman's rubber insulating mittens. They are constructed of the same high quality Grade A Red Boulevard buffed leather as the 156 series protectors. The SALCOR® “Super Cuff” is standard for 4” (102 mm) or 6” (152 mm) cuffs. With a non-metallic nylon pull strap fastened at the wrist, these protectors are designed for comfort and long wear.

Cat. No.	Cuff Length in. ( mm )	OAL Length in. ( mm )	Weight ea. lbs. ( kgs )
<b>103 SERIES</b>			
103-4	4 (102) Cuff	12 (305)	1.2 (.5)
103-6	6 (152) Cuff	14 (356)	1.3 (.6)

Available in sizes: 9 through 11 whole sizes



103-4

# LEATHER PROTECTORS

## ILP Series

Manufactured from top grain cowhide, or goatskin, these protectors provide excellent protection for rubber insulating gloves at a very economical price. Cowhide cuffs are tough leather on palm side and orange vinyl on the back, while the goatskin cuffs are green leather on palm side and orange vinyl on back. Full complement of styles from low-volt through 16" contour cuff. Comes in size 7, dual sizes 8/8.5 through 11/11.5 and size 12.

## ILPM Series Mitten Protector

Manufactured from top grain cowhide, these protectors offer excellent comfort and protection. The ILPM Series mitten protectors feature adjustable straps with non-metallic buckles and are stitched with polyester thread for strong seams. Cuffs are tough leather on palm side and orange vinyl on the back of the hand. Comes in sizes 9, 10 and 11.

## LP Series

Manufactured from top grain cowhide or goatskin, these protectors offer excellent comfort and protection. The LP Series protectors feature adjustable straps with non-metallic buckles and are stitched with polyester thread for strong seams. Cuffs are tough leather on palm side and orange vinyl on the back of the hand. Comes in sizes 7 to 12, including half sizes 8 1/2 to 11 1/2.



ILPG10



ILPG10A



ILPM5S



ILP7C



LPG3S



LP7C

LP6S

Cat. No.	OAL Length in. ( mm )	Weight ea. lbs. ( kgs )
<b>ILP SERIES - COWHIDE</b>		
ILP3S*	12 (305)	1 (.5)
ILP4S*	13 (330)	1 (.5)
ILP5S*	14 (356)	1.2 (.5)
ILP6S* / **	15 (381)	1.2 (.5)
ILP7C* / **	16 (406)	1.5 (.7)
ILP10*	10 (254)	.7 (.32)
ILP10A* w/ pull strap	10 (254)	.7 (.32)
*To specify goatskin, use ILPG. Goatskin not available in size 7. Available in dual sizes: 7, 8/8.5, 9/9.5, 10/10.5, 11/11.5, 12		
** Not available in size 7.		
<b>ILPM SERIES - COWHIDE</b>		
ILPM3S	12 (305)	1 (.5)
ILPM4S	13 (330)	1 (.5)
ILPM5S	14 (356)	1.2 (.5)
Available in sizes: 9, 10, 11		
<b>LP SERIES</b>		
LP3S	12 (305)	1 (.5)
LP4S	13 (330)	1 (.5)
LP5S	14 (356)	1.2 (.5)
LP6S	15 (381)	1.2 (.5)
LP7C	16 (406)	1.5 (.7)
LP10	10 (254)	.7 (.32)
LP10A w/ pull strap	10 (254)	.7 (.32)
To specify goatskin, use LPG. Available in single sizes: 8, 8.5, 9, 9.5, 10, 10.5, 11, 11.5, 12		

## GLOVE STORAGE & GLOVES KITS

*Proper storage extends the service life of linemen's gloves and sleeves.*

Folds and creases strain rubber and cause it to crack from ozone prematurely. By storing rubber gloves in the right size bag, and never forcing more than one pair into each bag, equipment will lie flat and last longer.

Salisbury bags are constructed of heavy duty canvas duck and are double stitched and riveted at stress points for extra durability. Canvas bags feature a D ring for hanging in trucks or on work belts. Bags feature tapered gussets with wide opening tops for easy insertion.



**New Glove and Protector Bags** contain two layered pockets in one bag. Now, both a pair of gloves and protectors can be properly stored in one convenient bag.



GB116

GB116GC

Cat. No.	For Glove length in. (mm)	Dimensions inches (mm)	Weight ea. lbs. (kgs)
<b>26 oz. CANVAS GLOVE BAGS</b>			
GB112	11 (280)	9" x 14" (229 x 356)	1 (.5)
GB114	14 (356)	9" x 16" (229 x 406)	1 (.5)
GB116	16 (406)	9" x 18" (229 x 457)	1.2 (.6)
GB118	18 (457)	9" x 20" (229 x 508)	1.5 (.7)
<b>26 oz. CANVAS GLOVE BAGS w/ goggle case</b>			
GB114GC	14 (356)	9" x 16" (229 x 406)	1 (.5)
GB116GC	16 (406)	9" x 18" (229 x 457)	1.2 (.6)
GB118GC	18 (457)	9" x 20" (229 x 508)	1.5 (.7)
<b>14.75 oz. CANVAS GLOVE &amp; PROTECTOR BAGS</b>			
GPB114	14 (356)	9" x 16" (229 x 406)	1 (.5)
GPB116	16 (406)	9" x 18" (229 x 457)	1.2 (.6)
GPB118	18 (457)	9" x 20" (229 x 508)	1.5 (.7)

### SALISBURY ADVANTAGE

#### Glove Kits

Salisbury's insulating rubber gloves are necessary for every electrical worker's complete safety. And to insure your safety, Salisbury's leather protectors provide needed protection from cuts, abrasions, and punctures. To keep these safety items in top condition, proper storage is very important.



GK011BL/9

#### Product Numbering Chart for Glove Kits

Class	Length (inches)	Color	Size of Gloves (choose one below)
GK 00	11 or 14	B, R, B, BL	7, 8, 9, 10, 11, 12
GK 0	11 or 14	R, BL, B, Y	7, 8, 9, 10, 11, 12
GK 2	14, 16, or 18	B, RB	7, 8, 9, 10, 11, 12

**Example:** GK011BL/9

Type I Natural Rubber available in: R=Red, Y=Yellow, B=Black, RB=Red in, Black out

Type II SALCOR® Rubber available in: BL=Blue

SALISBURY		1PR	
<b>Lineman's Gloves</b>			
Manufactured and tested in accordance with the current ASTM D-129 specification			
HA			
CATALOG NO.	TYPE	CLASS	LENGTH
E011BL/9	2	0	11
		DUFF	COLOR
		ST	BL
			9
P259 N Comp. Area Market S. 48077		Phone 877-688-4851 www.SALISBURY.COM	
		Made in the USA An-022-000-Company	
<b>Note:</b> If you require test date stamping, please specify when ordering.			

# SALISBURY

Setting industry standards since 1855. 7520 N Long Ave Skokie IL 60077 Toll Free 877.406.4501 Fax 847.679.2401

**Rubber Insulating Sleeves** extend coverage of the arm from the cuff of rubber insulating gloves to the shoulder— fully protecting these areas from accidental contact with energized conductors and equipment. Salisbury sleeves feature a reinforcing fold at the cuff. This fold is preferred over a rolled bead because it adds less bulk to the cuff and fits into the glove easier without pushing. Two different processes are used to manufacture insulating sleeves; dipping and molding. Both meet the current requirements of ASTM D1051 and offer the same high level of quality and protection.

**Sizing**

Sleeves should be selected to fit the arm comfortably, covering from the top of the shoulder to inside the top of the glove. Regular size sleeves are the shortest and have the smallest arm and wrist openings. To minimize the possibility of the sleeves pushing gloves off the hand, size the sleeve to the shortest length possible while maintaining complete coverage to the shoulder.



Sizing Linemen's Sleeves			
STRAIGHT ARM SLEEVE- Figure 1			
A	B	C	D
in. (mm)	in. (mm)	in. (mm)	in. (mm)
<b>Regular</b>			
26.25 (667)	15.5 (394)	11.25 (286)	5.5 (140)
<b>Large</b>			
28.5 (724)	17 (432)	12.87 (327)	6.87 (175)
<b>Extra Large</b>			
30 (762)	19 (483)	13.25 (337)	6.87 (175)
CURVED ARM SLEEVE- Figure 2			
A	B	C	D
in. (mm)	in. (mm)	in. (mm)	in. (mm)
<b>Regular</b>			
26.5 (673)	15.5 (394)	12.25 (311)	5.25 (146)
<b>Large</b>			
27.75 (705)	16 (406)	12.87 (327)	6.87 (175)
<b>Extra Large</b>			
29.5 (749)	17.5 (445)	12.87 (327)	7 (178)

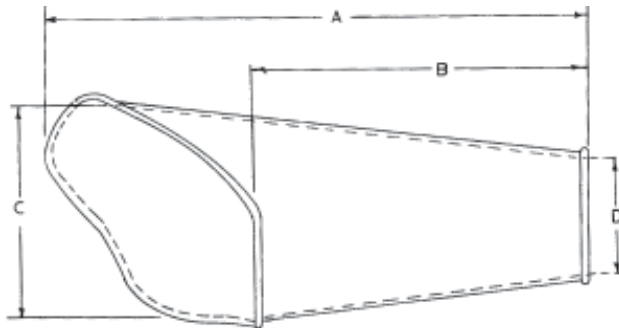

Figure 1

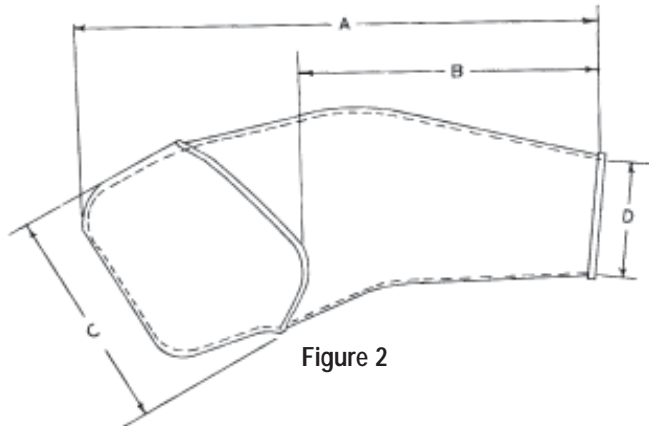

Figure 2



## LINEMEN'S SLEEVES

### Dipped

#### SALISBURY ADVANTAGE

**Dipped sleeves** are manufactured in the same way as Salisbury rubber insulating gloves. Porcelain forms are dipped into liquefied rubber, dried, trimmed, marked and cured. Every sleeve receives the same quality inspections and electrical testing before shipping. Dipped sleeves are available in the same colors as dipped gloves, including two color combinations.

Salisbury is the only manufacturer that offers three popular styles of dipped lineman's sleeves: straight, curved, and extra-curved. All styles are available in every color or color combination, size, and voltage class. Most importantly, all are made to the same rigid levels of quality demanded by Salisbury.

*Only Salisbury offers both dipped and molded sleeves.*



Extra-Curved Arm  
D2LYR-EC



Curved Arm  
D2LYB



Straight Arm  
D2RYB-ST

#### Cat. No. Breakdown for Dipped Type I Sleeves

Voltage Class	Size	Color
D0	R, L or XL	Y=yellow
D1	R, L or XL	R=red
D2	R, L or XL	B=black
D3	R, L or XL	YB=Y inside, B out
D4	R, L or XL	RB=R inside, B out
R=regular L=large XL=extra large		YR=Y inside, R out
Example: D2LYB		

Add suffix "-ST" to order straight cuff or "-EC" to order extra-curved cuff  
**Note:** Special lengths available. Please contact your local Salisbury Representative for more information.

# LINEMEN'S SLEEVES

## Molded

**Molded sleeves** are manufactured by either injection or compression molding methods. The advantage these methods offer is the ability to produce sleeves of Type I or SALCOR® Type II synthetic rubber. SALCOR sleeves provide the same high quality and electrical protection as natural rubber, with the added benefit of being resistant to ozone and ultraviolet radiation. Type I sleeves are available in black, yellow or maroon. Type II SALCOR sleeves are black or orange. Molded sleeves are available in curved arm style only.



Black  
Type I  
2RB



Yellow  
Type I  
3LY



Orange  
Type II  
2ROS

Cat. No. Breakdown for Molded Type I Sleeves		
Voltage Class	Size	Color
1	R or L	Y
2	R, L or XL	B, Y, M
3	R or L	Y, M
4	R or L	M
R=regular L=large XL=extra large		B=black Y=yellow
Example:2LB		M=maroon

Cat. No. Breakdown for Molded Type II Sleeves		
Voltage Class	Size	Color
1	R or L	BS or OS
2	R, L or XL	BS or OS
R=regular L=large XL=extra large		BS=black SALCOR
Example:2LOS		OS=orange SALCOR

## SLEEVE STORAGE & ACCESSORIES

*Proper storage extends the service life of linemen's sleeves.*

Folds and creases strain rubber and cause it to crack from ozone prematurely. By storing rubber sleeves in the right size bag, and never forcing more than one pair into each bag, equipment will lie flat and extend the life of the product.

Salisbury bags are constructed of heavy duty canvas duck and are double stitched and riveted at stress points for extra durability. Canvas bags feature a D ring for hanging in trucks or on work belts. Bags feature tapered gussets with wide opening tops for easy insertion.

### SALISBURY ADVANTAGE

The **T32** bag contains a **crush resistant** lining to create a more protective environment for your sleeves.

**Sleeve buttons, straps, and harnesses** are required to wear rubber insulating sleeves properly. Four buttons are required per pair of sleeves. Two straps are required per pair of sleeves. One harness is required per pair of sleeves.



T32

T31

Cat. No.	For Sleeve length in. ( mm )	Dimensions inches ( mm )	Weight ea. lbs. ( kgs )
<b>CANVAS SLEEVE BAG</b>			
T31	-	30" x 9.5" ( 762 x 241mm )	1.5 ( . 7 )
T32	-	30" x 13" ( 762 x 330 mm )	3 ( 1.4 )
<b>BUTTONS</b>			
B2	-	One Piece Sleeve Button	.2 ( .01 )
B22	-	4 Screw Type Buttons	.8 ( .04 )
<b>STRAPS</b>			
S1	15"(381mm)	Strap w/ 4 B2 Buttons	.1 ( .005 )
<b>HARNESS</b>			
H1		Harness w/ 4 B2 Buttons	1 ( .45 )

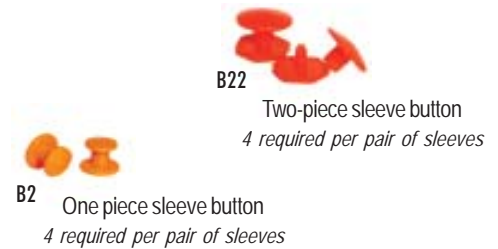

B22

Two-piece sleeve button  
4 required per pair of sleeves

B2

One piece sleeve button  
4 required per pair of sleeves



S1

H1

**SALISBURY**

Setting industry standards since 1855. 7520 N Long Ave Skokie IL 60077 Toll Free 877.406.4501 Fax 847.679.2401

## SALISBURY LINEMEN'S GLOVE LINERS

**Liner Gloves** enhance the comfort of wearing Rubber Insulating Gloves in every season. Liners provide warmth in the cold season and absorb perspiration in the warm months. Many styles and fabrics are available with either an open or knit wrist.



The knit wrist style grips the wrist rather than allowing the cuff to roll down and bunch at the palm. All Liner Gloves are for year round use with Rubber Insulating Gloves and Mittens. All liners are made from stretch fabric that can fit any hand size.

The **L Series** has a tough outer cotton fabric while the inner lining is soft and comfortable. The **LMKC Series** is light, airy and allows ease of movement. The **LMKW Series** is made from a cotton and wool blend fabric that moves easily yet gives a substantial layer of lining.



The **89 Series** is Salisbury's classic summer and winter glove liner. Liners absorb perspiration from hands. The summer liner is white in color and 100% cotton. The winter blend is a rust color and 100% acrylic.



Cat. No.	Description	Wrist Style	Length in. ( mm )	Weight ea. lbs. ( kgs )
L10JK	Jersey Style, Light Weight, Seams Out	Knit	10 ( 254 )	.14 (.06)
L10J	Jersey Style, Light Weight, Seams Out	Open	10 ( 254 )	.12 (.06)
L12J	Jersey Style, Light Weight, Seams Out	Open	12 ( 305 )	.14 (.07)
L10MKC	Machine Knit, 100% Cotton	Knit	10 ( 254 )	.12 (.05)
L12MKC	Machine Knit, 100% Cotton	Knit	12 ( 305 )	.12 (.05)
L10MKW	Machine Knit, Cotton/Wool Blend	Knit	10 ( 254 )	.14 (.06)
L12MKW	Machine Knit, Cotton/Wool Blend	Knit	12 ( 305 )	.14 (.07)
89/1402	White Machine Knit, 100% Cotton	Knit	10 ( 254 )	.12 (.06)
89/4702	Rust Machine Knit, 100% Acrylic	Knit	10 ( 254 )	.12 (.06)

One size fits all.

## SALPOL & WORK GLOVES

Salisbury's **SALPOL Gloves** protect hands during cold weather jobs. The black split cowhide leather has a 3M Thinsulate\* lining to keep hands warm. For extra warmth a long knit wrist is sewn into the safety cuff to keep out snow and ice. The glove also has a full leather index finger, knuckle strap, leather fingertips, and pull patch.

\*Thinsulate is a registered Trademark of the 3M Company.

Salisbury **WorkGloves** are constructed of soft, flexible, yet tough premium grade unlined leather. Designed for comfort and long wear, with leather finger tip reinforcements. Work Gloves are offered with a 2" (51mm) leather safety cuff or with a 4.5" (114mm) leather gauntlet cuff.

**Drivers Work Gloves** set the standard for quality at an affordable price. Combining comfort, durability and economy, Salisbury leather Drivers Work Gloves meet the tough challenges of today's demanding workplace. Available in lined or unlined styles. The bindings are color coded to indicate size: red-small, green-medium, brown-large, purple-extra large.

**Linemen Work Gloves** are designed specifically for use by linemen and offers many of the quality features found in our leather protectors. Made from high quality grain cowhide or goatskin, this glove is soft and flexible, while still being highly abrasion and cut resistant for long wear.



SP-L



312W

316W



195/217/WHS



LW2SPE

SALPOL GLOVES & WORKGLOVES			
Cat. No.	Description	Length in. ( mm )	Weight ea. lbs. ( kgs )
<b>SALPOL GLOVES</b>			
SP-S	Small Size Polar Glove	n / a	.5 ( .23 )
SP-L	Large Size Polar Glove	n / a	.5 ( .23 )
<b>WORKGLOVES</b>			
312W*	Safety Cuff Style	10 ( 254 )	.8 ( .4 )
316W*	Gauntlet Cuff Style	12.5 ( 318 )	1 ( .5 )
*Add "-S" for small, "-M" for medium, "-L" for large, "-XL" for extra-large.			
DRIVERS & LINEMEN WORK GLOVES			
Cat. No.	Description		Weight ea. lbs. ( kgs )
195/217/WHS*	Unlined		.3 ( .14 )
195/317/WHS*	Lined		.3 ( .14 )
*Add "-S" for small, "-M" for medium, "-L" for large, "-XL" for extra-large.			
LW2SPE**	Cowhide leather, natural pigskin cuff		.4 ( .18 )
LWG2SPE**	Goatskin leather, natural pigskin cuff		.4 ( .18 )
**Add "-M" for medium, "-L" for large, "-XL" for extra-large.			

# SALISBURY

Setting industry standards since 1855. 7520 N Long Ave Skokie IL 60077 Toll Free 877.406.4501 Fax 847.679.2401

## CLEANERS, SUNSCREEN AND SUPPLIES



**RUB-OUT™** is a non-petroleum-based hand cleaner for workers who wear rubber gloves and sleeves. Dissolves and removes grease, oil, ink, tar, pipe dope, creosote, paint and more without harming natural rubber or SALCOR® rubber. Cleans with or without water. Contains natural skin conditioners and leaves a fresh citrus scent.

Salisbury's **RUB-OUT™ Towelettes** are premoistened heavy duty hand cleaner towels that work fast to loosen, dissolve, and absorb dirt and grease, and will not harm rubber gloves! Our powerful yet safe cleaning agents work together with an absorbent, nonscratching abrasive cleaning towel. The citrus-based formula easily removes soil from your hands and leaves them cleaned and conditioned anywhere you're working. *And after cleaning your hands there is enough absorbency to clean your tools and other surfaces with the same towel.* These shop size (10.5" x 12.25") durable towels quickly remove tough-to-clean substances including lubricants, tar, oils, wax, caulk and much more.

**TEN-FOUR GLOVE DUST** is a cooling, frictionless powder that absorbs moisture and perspiration when wearing rubber gloves. Provides extra comfort while preventing gloves from getting sticky. The 6-oz. bottle easily fits in a pocket or glove bag. The 4-quart bulk package is used in test labs as a dusting powder when cleaning and testing.

**SUPER SALCO® Cleaner** is a concentrated detergent with a special grease release formula that removes oils, grease and dirt from natural rubber and SALCOR rubber equipment. Suitable for washing linemen's rubber gloves, sleeves and other specialty equipment, by hand or in commercial washing machines. Also works well on fiberglass and other materials. Just dilute with water, apply with a rag or sponge and rinse thoroughly.

Cat. No.	Description	Weight ea. lbs. (kgs)
<b>RUBOUT HAND CLEANER</b>		
1450	4.5 oz. (130g) tubes, 12/pack	4 (1.8)
1451	16 oz. (.45kg) can, 12/pack	16 (7.3)
1452	4.5 lbs. (2kgs) cans, 6/pack	28 (12.7)
1453	Dispenser for 4.5lb. (2kg) can	1 (.5)
<b>RUBOUT TOWELETTES</b>		
1460	Bucket of 60, 6 buckets / Case	14 (6.4)
1461	Single Packets, 100 Singles / Case	3 (1.4)
<b>TEN-FOUR GLOVE DUST</b>		
10-4	12 @ 6 oz. (170g) squeeze bottles	5.5(2.2)
10-4-4QT	4 quarts (3.8 ltrs.) bulk, single	8 (3.6)
<b>SUPER SALCO DETERGENT</b>		
S4	1 gal (3.8 ltr.) jugs, 4 pack	54(24.5)
S5	5 gal (19 ltr.) drum	49 (22.3)
S55	55 gal (208 ltr.) drum	540 (245)
<b>SALCON SILICONE SPRAY</b>		
S99	Aerosol can	16 oz. (.454)
<b>SUNSCREEN 30</b>		
SS30	100 towelettes	6 (2.72)

**SALCON® Silicone Spray** is specially formulated to reduce friction on SALCOR or natural rubber products. Reduces surface creepage on rubber gloves and sleeves. Forms an oxygen barrier which helps reduce corona cutting and weather checking on rubber equipment. May also be used to spray spark plugs and battery terminals in damp weather to assist in starting.

**SUNSCREEN 30** is a non-oily sunscreen that does the job for at least four hours. Safe for leather and rubber gloves, leaves no residue—no slippery hands. Large convenient towelettes.

# DIELECTRIC BOOTS



## ASTM DIELECTRIC FOOTWEAR

### Deep Heel Overshoes - Tested at 20kV per ASTM F1116

ASTM Dielectric Footwear provides extra safety when climbing ladders and poles where the deep heel cavity can lock onto the rungs. These boots and overshoes are 100% waterproof and made from premium grade ozone resistant rubber. The construction is hand-layered in full-cut patterns to fit over work boots. The fabric lining makes them easy to get on and off. The sole has a durable construction with a non-skid bar tread outsole. Salisbury Dielectric Footwear conforms with ASTM F1117 and is 100% tested to ASTM F1116 at 20,000 volts.

ASTM Dielectric Footwear comes in four styles all with pole-climbing reinforcement patch. The **Storm Rubber Overshoe** is available without buckles or with two buckles. The **Full-Cut Overshoe** with adjustable side strap features a 12" height or a 17" height. The attached buckle and hardware is nonmetallic. Manufactured in the U.S.A.

**All of these overshoes and boots have been tested to the electrical hazard requirements of ASTM F1116. ASTM Dielectric footwear has been tested to 20,000 volts.**



Cat. No.	Description	Sizes in. ( mm )	Weight pr. lbs. ( kgs )
21405	17", 1 Buckle Full Cut Overshoe	Whole Sizes 7 - 17	5.8 ( 2.6 )
21406	12" 1 Buckle Full Cut Overshoe	Whole Sizes 7 - 17	5.0 ( 2.3 )
51508	Storm Rubber	Whole Sizes 7 - 17	3.3 ( 1.5 )
51509	2 Buckle	Whole Sizes 7 - 17	4.4 ( 2 )



## SUPER DIELECTRIC - ASTM F2413-05

### Deep Heel Overshoes, Outsole Tested to 20kV

#### Super Dielectric Deep Heel Overshoes

provide extra safety when climbing ladders and poles where the deep heel cavity can lock onto the rungs. These boots and overshoes are made from an ozone resistant yellow rubber that's 100% waterproof. The construction is hand-layered in full-cut patterns to fit over work boots. The fabric lining makes them easy get on and off. The sole is an anti-skid bar thread. The outsole of these overshoes and boots have been tested to 20,000 volts to the electrical hazard requirements of ASTM F2413-05.

Super Dielectric Deep Heel Overshoes come in three styles all with pole-climbing reinforcement patch. The **Storm Rubber Overshoe** is available without buckles or with two buckles. The **Full-Cut Overshoe** with adjustable side strap features a 17" height.



51581



51530



Anti-Skid  
Bar Tread



21402

**SERVUS**

Cat. No.	Sizes	Description in. ( mm )	Weight pr. lbs. ( kgs )
21402	Whole Sizes 7-17	17" ( 432 ) Overshoe	5.8 ( 2.6 )
51530	Whole Sizes 6-17	2-Buckle	4.4 ( 2 )
51581	Whole & Half Sizes 7-12, Whole Sizes 5, 6, 13-17	Storm Rubber	3.3 ( 1.5 )

#### ANSI Z41 vs. ASTM F2413-05 Standards

ANSI Z41 standard, *Standard for Personal Protection Protective Footwear*, has been WITHDRAWN, and is REPLACED by new ASTM standards. The new ASTM International standards replacing and updating the Z41 document are entitled F2412-05 *Standard Test Methods for Foot Protection* and F2413-05 *Standard Requirements for Protective Footwear*.

The new ASTM standards contain minimal changes from the withdrawn ANSI Z41 1999 standard with regard to test methodology. The major performance characteristics changes between the new ASTM standard and the old ANSI standard are the removal of Type II Static Dissipative and Class 30 for impact and compression requirements. Therefore, the majority of existing industry inventory of product and product-information that is labeled or advertised as in compliance with the ANSI Z41 1999 standard is compliant with the new ASTM standards.

## **SUPER DIELECTRIC - ASTM F2413-05**

### **Overshoes, Outsole Tested to 20kV**

**Super Dielectric Overshoes** are made from an ozone resistant yellow rubber. The construction is hand-layered in full-cut patterns to easily fit over work boots. These overshoes are 100% waterproof. The lining is fabric so they easily slip on and off. The sole is an anti-skid bar tread. The outsole of these overshoes and boots have been tested to 20,000 volts to the electrical hazard requirements of ASTM F2413-05.

Super Dielectric Overshoes are available in two styles: a Storm Rubber Overshoe and an 11" 4-Buckle Arctic both with a pole-climbing reinforcement patch.



51824



Anti-Skid  
Bar Tread



31924

# **SERVUS®**

Cat. No.	Sizes	Description in. ( mm )	Weight pr. lbs. ( kgs )
31924	Whole Sizes 6-17	11" ( 279 ) 4-Buckle Arctic	4.6 ( 2.1 )
51824	Whole & Half Sizes 7-12	Storm Rubber	3.25 ( 1.5 )
	Whole Sizes 13-17		

## **SALISBURY**

Setting industry standards since 1855. 7520 N Long Ave Skokie IL 60077 Toll Free 877.406.4501 Fax 847.679.2401

**DIELECTRIC - ASTM F2413-05**  
**Overshoes, Outsole Tested to 14kV**

**Dielectric Overshoes** are made from yellow ozone resistant rubber that's 100% waterproof. The construction is hand-layered in full-cut patterns to easily slip over work shoes. The lining is fabric so they easily slip on and off. The outsole of these overshoes and boots have been tested to 14,000 volts to the electrical hazard requirements of ASTM F2413-05.

Dielectric Overshoes come in two styles. The **Deep Heel Lineman's Storm Rubber** has a diamond V-grip outsole and pole-climbing reinforcement patch. The **11" 4-Buckle** has an anti-skid bar tread sole and heel.



Diamond V-grip  
Outsole



51510



31910



Anti-Skid  
Bar Tread

Cat. No.	Sizes	Description in. ( mm )	Weight pr. lbs. ( kgs )
31910	Whole Sizes 7-17	11" ( 279 ) 4-Buckle	3.8 ( 1.7 )
51510	Whole & Half Sizes 6-12, Whole Sizes 13-17	Deep Heel Storm Rubber	3.1 ( 1.4 )

## INSULATED JUMPERS



## INSULATED JUMPERS



### **SALISBURY ADVANTAGE**

Insulated bypass jumper sets consist of three basic components: one pair of clamps, one pair of ferrules, and a length of insulated cable. Many of the most popular jumper sets are listed on the following pages associated with each of the different types of jumper clamps. When a custom jumper is required, follow this procedure to ensure that a complete and functional jumper is specified.

*If you need assembled jumper sets, quickly, please contact your local Salisbury Representative for more information.*

*Let Salisbury professionally assemble your sets for you.*

**All Salisbury Insulating Jumpers meet ASTM F2321 standards.**

### Insulated Jumper Checklist



1. Specify the style of insulated clamps. All of the clamps are hand installed wearing rubber insulating gloves, accept either shrouded or unshrouded ferrules, and accept insulated cable up to 4/0, 35kV. Insulated jumper clamps are sold in pairs.
2. Specify the size and length of insulated cable. Salisbury offers 15kV cable from #2 to 4/0. 25 and 35 kV cable are both available in sizes 1/0 and 2/0. Be sure to specify the length of the cable chosen.
3. Specify the size and style of ferrules required. The size of the ferrule will be determined by the size of the cable. Specify the appropriate ferrule catalog number for either shrouded or unshrouded ferrules. Both types are sold in pairs.
4. Specify if the jumpers are to be factory assembled. A complete jumper set with crimped ferrules and installed jumper clamps will be supplied. Salisbury has state of the art computer controlled crimping available.
5. Specify if there are any special requirements. This could include heat shrink tubing, special assembly instructions, markings, packaging etc.

**SALISBURY**

Setting industry standards since 1855. 7520 N Long Ave Skokie IL 60077 Toll Free 877.406.4501 Fax 847.679.2401

# LOCKING INSULATED JUMPER CLAMPS

## The Salisbury Sure-lok™ Jumper Clamp

The Salisbury Sure-lok™ Jumper clamp is a revolutionary improvement over any other jumper clamp in the world. Featuring a ratchet type locking mechanism (patent pending), this is the only clamp available **guaranteed not to loosen** once installed on a line.

Loose Jumper clamps not only jeopardize your safety but can also cause fires and power outages. Even when torqued using wrenches or pliers, traditional clamps will eventually loosen from line vibrations and thermal cycling. This clamp tightens with a ratchet action using one hand, with no extra tools for a secure, positive connection. It can't come loose until you want it to. Pull and turn the locking knob and it loosens like any traditional clamp.

Available in our exclusive SALCOR® material and the industry's most durable single piece clear plastic jumper clamps.

*Custom built assemblies are available. Contact your local Salisbury Representative for more information.*

1786



2261  
SALCOR Sure-lok™



	Cat. No.	Main Line Range	Max Amps Continuous	Rating	OAL Length in. ( mm )	Weight ea. lbs. ( kgs )
SALCOR	2261	477 MCM (.9"-.162")	400	36 kV Ø-Ø	11.5 (292 mm)	10 (4.5)
	2271	954 MCM (1.25"-.162")	400	21 kV Ø-GRD	11.5 (292 mm)	11 (5)
Clear Plastic	1786	477 MCM (.9"-.162")	400	36 kV Ø-Ø	11.5 (292 mm)	8 (3.6)
	2116	954 MCM (1.25"-.162")	400	21 kV Ø-GRD	11.5 (292 mm)	10 (4.5)

## SALCOR® INSULATED JUMPER CLAMPS

SALCOR® Jumper Clamps are available in two main line sizes with a maximum use voltage of 35kV.

The SALCOR Jumper Clamp not only provides a superior grip, but also resists ozone cutting and tracking. Being molded of rubber, these handles are inherently impact resistant and extremely durable. The body and jaw are made from a copper base alloy. The lower ring contact is made of self lubricating bronze. Assemble jumpers with insulated jumper cable and 5/8" - 11 NC threaded ferrules. Assembled kits are sold with a 10 ft. ( 3m ) cable and unshrouded ferrules.

*Custom built assemblies are available.  
Contact your local Salisbury  
Representative for more information.*



Cat. No.	Main Line Range	Max Amps Continuous	Rating	OAL Length in. ( mm )	Weight ea. lbs. ( kgs )
2260	477 MCM (.9"-1.62")	400	36 kV Ø-Ø	11.5 ( 292 mm )	10 ( 4.5 )
2270	954 MCM (1.25"-1.62")	400	21 kV Ø-GRD	11.5 ( 292 mm )	11 ( 5 )

Assembled 10 ft. / 3m Jumper Sets ( Unshrouded Ferrules )						
	Jumper Cat. No.	Cable Size	Cable Cat. No.	Ferrule Cat. No.	Max Amps Continuous	Weight ea. lbs. ( kgs )
2260 Clamp	2264	#2-15 kV	2754	2022	200	10.9 ( 4.9 )
	2265	1/0-15 kV	2755	2023	250	13.5 ( 6.1 )
	2266	2/0-15 kV	2756	2024	300	14.8 ( 6.8 )
2270 Clamp	2274	#2-15 kV	2754	2022	200	11.9 ( 5.4 )
	2275	1/0-15 kV	2755	2023	250	14.6 ( 6.8 )
	2276	2/0-15 kV	2756	2024	300	15.9 ( 7.2 )

## CLEAR PLASTIC & FRP INSULATED JUMPER CLAMPS

Salisbury's superior stress cracking resistant Clear Jumper Clamps are available in two main line sizes with a maximum use voltage of 35kV. Assemble these clamps with insulated jumper cable and 5/8" - 11 NC threaded ferrules.

**Clear Plastic Jumper Clamps** are compact, lightweight, and virtually unbreakable. The transparency allows easy inspection of the ferrule and cable inside of the handle. The body and jaw are made from a copper base alloy. The lower floating ring contact is bronze. These handles should be cleaned only with a mild detergent to maintain the transparency of the handle. Assembled kits are sold with a 10 ft. (3m) cable and unshrouded ferrules.

**FRP Jumper Clamps** are designed for maximum loads, voltages, and cables. During a temperature rise test at 25% overload, these clamps heated 35% less than 4/0 cu. cable. Blunted points on the handle provide optimum grip, resist impact, and will not soften with overloads. The body and jaw are made from a copper based alloy. The lower jaw is made of self lubricating bronze. The assembled jumpers are sold with a 10ft. (3m) or 12 ft. (3.7m) cable and unshrouded ferrules.

*Custom built assemblies are available. Contact your local Salisbury Representative for more information.*



2115



1785



Clear Jumper with Cable



1610

Cat. No.	Main Line Range	Max Amps Continuous	Rating	OAL Length in. ( mm )	Weight ea. lbs. ( kgs )
1610	954 MCM (1.25"-1.62")	400	36 kV Ø-Ø 21 kV Ø-GRD	11 (279)	14 (6.4)
1785	477 MCM (.9"-1.62")	400	36 kV Ø-Ø	11.5 (292 mm)	8 (3.6)
2115	954 MCM (1.25"-1.62")	400	21 kV Ø-GRD	11.5 (292 mm)	10 (4.5)

### Assembled 10 ft. / 3m Jumper Sets ( Unshrouded Ferrules )

	Jumper Cat. No.	Cable Size	Cable Cat. No.	Ferrule Cat. No.	Max Amps Continuous	Weight ea. lbs. ( kgs )
1785 Clamp	2067	#2-15 kV	2754	2022	200	9.9 (4.5)
	2178	2/0-15 kV	2756	2024	300	13.9 (6.3)
2115 Clamp	2074R1	#2-15 kV	2754	2022	200	10.9 (4.9)
	2164	2/0-15 kV	2756	2024	300	14.8 (6.8)
	2174R1	1/0-15 kV	2755	2023	250	16.8 (7.6)

### Assembled Jumper Sets ( Unshrouded Ferrules )

	Jumper Cat. No.	Cable Length	Cable Size	Cable Cat. No.	Ferrule Cat. No.	Max Amps Continuous	Weight ea. lbs. ( kgs )
1610 Clamp	2772	10'	2/0-15kV	2756	2024	300	5.8 (2.9)
	2773	10'	4/0-15kV	2757	2025	400	20.3 (9.2)
	2450	10'	1/0-15kV	2755	2023	250	15 (6.8)
	2066	12'	1/0-35kV	2059	2023	250	20.3 (9.2)
	20876	12'	2/0-35kV	4370	2024	300	21.5 (9.8)



## INSULATED JUMPER CLAMPS ACCESSORIES

**Stirrup Clamps** are used to convert a hand installed jumper into a stick installed jumper. The stirrup is designed to accept all conventional jumper heads.

The **Hot Jumper Parking Stand** safely holds either hand or stick installed hot bypass jumpers. This insulated tool removes the risk of accidental contact with the uninstalled end of an energized jumper. Installs by hand using rubber insulating gloves or with a standard shotgun stick. The fiberglass jumper hanger bar will accommodate standard size mechanical jumper heads.

The **Connector Link** connects two insulated jumpers to create a longer jumper length. After the two clamps are connected to the link, the assembly can be wrapped with a small rubber insulating blanket.



21132RG



Parking Stand Installation with Shotgun Stick



4245



2750



Cat. No.	Main Line Range	Description	Max. Amps Continuous	Weight ea. lbs. ( kgs )
2750	-	Connector Link	400	.3 ( .1 )
21132RG	1033 MCM ASCR to #6 Sol. 1.25"-.16" ( 32-4.1mm )	Hot Jumper Stirrup Clamp	400	3.0 ( 1.4 )
4245	954 MCM ACSR to #6 Sol. 1.14"-.16" ( 29- 4.1 mm )	Parking Stand for Hot Jumpers	n / a	3.5 ( 1.6 )

## STICK INSTALLED FLEXIBLE JUMPERS

**Stick Installed Flexible Jumpers** can be manufactured for hot stick operations using Salisbury heavy-duty eye clamps. Clamps are rated for continuous current and fit all standard shotgun type hot sticks. For ease of application, a Hanger Stud is recommended. Shrouded ferrules are not recommended for use with eye type clamps.

*Custom built assemblies are available. Contact your local Salisbury Representative for more information.*



2300

Cat. No.	Main Line Range	Max Amps Continuous	Components	Rating	Weight ea. lbs. (kgs)
2300	1431 ACSR	250	2#1895 Alum "C" Clamp 1#1928A Hanger Stud	15 kV Ø-Ø	16 (7.3)
			1#2027 Alum Ferrule 10' #2755 1/0 15kV Cable		
2308	to #6 Sol.	200	2#1895 Alum "C" Clamp 1#1928A Hanger Stud	15 kV Ø-Ø	10.8 (4.9)
			1#2026 Alum Ferrule 12' #2754 #2 15kV Cable		
2317	1.5"- .16"	250	2#2195 Alum "C" Clamp 1#1928A Hanger Stud	35 kV Ø-Ø	16 (7.3)
			1#2027 Alum Ferrule 12' #2059 1/0 35kV Cable		
2318		300	2#2318 Alum "C" Clamp 1#1928A Hanger Stud	15 kV Ø-Ø	15.6 (7.1)
			1#2620 Alum Ferrule 12' #2756 2/0 15kV Cable		
2559	1033 ACSR	250	2#1853 Alum Duckbill Clamp 1#1858A Hanger Stud	15 kV Ø-Ø	16 (7.3)
	to #6 Sol.		1#2027 Alum Ferrule 10' #2755 1/0 15kV Cable		
	1.25"- .16"				
2877	795 ACSR	250	2#2532 Alum "C" Clamp 1#2537A Hanger Stud	15 kV Ø-Ø	11 (5.0)
	to #8 Sol.		1#2027 Alum Ferrule 10' #2755 1/0 15kV Cable		
9976	1.12"- .12"	250	2#9985 Brnz "C" Clamp 1#9983A Hanger Stud	15 kV Ø-Ø	12 (5.4)
			1#2023 Cu Ferrule 10' #2755 1/0 15kV Cable		
9977		250	2#2937 Brnz "C" Clamp 1#9983A Hanger Stud	35 kV Ø-Ø	12.5 (5.6)
			1#2023 Cu Ferrule 10' #2059 1/0 35kV Cable		

## FLEXIBLE INSULATED JUMPER CABLES

**Flexible Insulated Jumper Cables** are lightweight and resistant to oil, heat, moisture, ozone and abrasion. The cable is embossed every three feet with conductor size and kV rating.

All jumper cables use fine stranded conductor and a new EPR low temperature Unipass orange CV cured jacket. The fine stranded copper conductor is alloy coated and assembled in a unidirectional rope lay for extra flexibility. The conductor has a semiconducting shield surrounding it to relieve voltage stress and improve dielectric strength and service life.



Cable meets requirements of ASTM F2321.

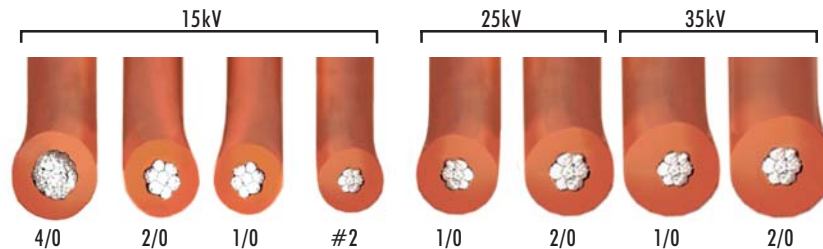

Cat. No.	Size & Str. AWG	kV Rating Ø to Ø	Nominal Ø to Grd	Str. Dia. in. ( mm )	O.A. Dia. in. ( mm )	Max Amps Continuous	Weight per 1000 ft.	
							lbs.	kgs
2754	#2-259W	15	10	.320 ( 8.1 )	.75 ( 19 )	200	440	199
2755	1/0-413W	15	10	.403 ( 10.2 )	.83 ( 21 )	250	600	272
2756	2/0-427W	15	10	.456 ( 11.5 )	.90 ( 23 )	300	710	322
2757	4/0-437W	15	10	.592 ( 15.0 )	1.01 ( 25.6 )	400	1050	476
21300	1/0-413W	25	15	.403 ( 10.2 )	1.06 ( 27 )	250	650	295
21060	2/0-427W	25	15	.456 ( 11.5 )	1.10 ( 28 )	300	750	341
2059	1/0-413W	35	20	.403 ( 10.2 )	1.22 ( 31 )	250	950	431
4370	2/0-427W	35	20	.48 ( 12.1 )	1.31 ( 33.1 )	300	1060	482

## FERRULES

### Shrouded / Unshrouded

**Ferrules** are manufactured in two different styles: unshrouded and shrouded. Shrouded ferrules are compressed on both the conductor and the insulating jacket of the high voltage EPR cable to reduce bending stress. Shrouded ferrules are designed to be used on glove-installed high voltage jumpers. Unshrouded ferrules are crimped to the conductor strands only and can be used on either stick- or glove-installed jumpers.

**Ferrules** are manufactured of 99.5% pure copper with industry standard 5/8"-11 NC threads. Ferrules are topped with a brass hex jam nut and toothed stainless steel lockwasher.



shrouded



unshrouded

Cat. No. Pair	Cable Size	Strand Die Codes T&B	Jacket Die Codes T&B	Burndy Die Number	Weight ea. lbs. ( kgs )
<b>SHROUDED</b>					
2012	#2-15 kV ERP	66	106	-	1.2 (.5)
2013	1/0-15 kV ERP	66	106	-	1.2 (.5)
2014	2/0-15 kV ERP	66	106	-	1.1 (.5)
2015	4/0-15 kV ERP	66	106	-	0.9 (.4)
21353	1/0-25 kV	66	112	-	1.1 (.5)
21354	2/0-25 kV	66	112	-	1.1 (.5)
21356	2/0-35 kV	66	125	-	1.1 (.5)
<b>UNSHROUDED - Tin Plated</b>					
		<b>Strand Die Codes</b>			
2022	#2	50	-	U243	0.5 (.2)
2023	1/0	50	-	U243	0.4 (.2)
2024	2/0	60	-	U245	0.4 (.2)
2025	4/0	66	-	U247	0.6 (.3)

Add suffix "A" to the catalog number when requesting a custom insulated jumper set.

# TEMPORARY PROTECTIVE GROUNDING EQUIPMENT



Our complete line of grounding equipment offers solutions for utility and industrial applications. Whether you prefer complete assemblies or individual components, Salisbury has a product to meet your needs.

## Salisbury's Grounding Configurator™

Salisbury's Grounding Configurator™ makes ordering grounding equipment simple and easy. This interactive web tool allows you to easily build the proper temporary grounding equipment for your specific needs. The step by step process takes out the guess work, and makes it easy to change components until the most appropriate ground set is developed.

Just go to our web site and give it a try. You will be prompted from start to finish. All you need to know is the maximum fault current, its duration and the size of cable required on the fault, and the configurator will do the rest. No more second guessing quantities or parts to be sure that you have put together a ground set that will function just as you expect. When you finish, enter your personal information and the configurator will instantly provide you with the bill of materials including part numbers. All that's left to do is to place the order!

Visit [whsalisbury.com/configurator](http://whsalisbury.com/configurator) to use Salisbury's exclusive Grounding Configurator™.



### How to specify temporary protective grounding assemblies.

A grounding assembly in its basic form consists of two clamps, one pair of ferrules and a length of cable.

The clamps can be identical to each other or quite different depending on each grounding application. Because of this, ground clamps are sold individually, not in pairs. Salisbury offers a wide variety of clamps including C-clamps, flat jaw clamps, socket clamps, duckbill clamps and specialty clamps for unique situations. Clamps are offered in either bronze or aluminum alloys and are manufactured to meet the current specifications of ASTM F 855.

To attach a clamp to the grounding cable requires the use of a ferrule. Ferrules are compressed on the strands of the cable to provide a low resistance permanent connection. The size of the ferrule is determined by the size of the cable. Ferrules are available in aluminum or plated copper. Plated copper ferrules can be used with either aluminum or bronze clamps. Aluminum ferrules can be used with aluminum clamps only. Two ferrules are required for each assembly therefore they are sold in pairs. Ferrules are manufactured to the specifications of ASTM F 855.

The final component that makes up a ground set is the grounding cable itself. The size of the cable is dependent on the short circuit current capacity of the system being grounded. Once this is determined, only the length of the cable and the color of the jacket need to be specified to complete the assembly.



### Ground Set Checklist

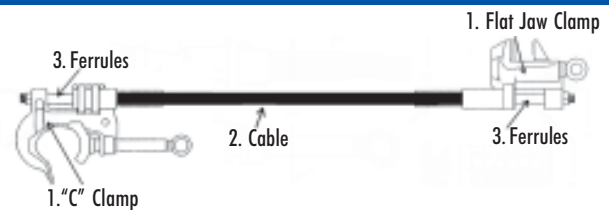

1. Specify the clamps. Two are required for a complete assembly. The maximum amperage of the clamp is designated by the ASTM grade of each clamp. Be sure that the clamp will meet or exceed the maximum amperage rating of the ground cable that it will be used with.
2. Specify the cable. Once the short circuit capacity of the system has been determined, choose the appropriate size cable. Specify the cable length, and the color of the jacket desired.
3. Specify the ferrules. One pair of ferrules is required per assembly. The size of the ferrule must match the size of the cable that it will be used with. Specify whether copper or aluminum, and threaded or plain.
4. Specify the options. List any optional equipment that is desired. This can include hanger studs, contact studs, heat shrink tubing, markings, clear strain relief, etc.

## DUCK BILL GROUNDING CLAMPS



21081 - Stick Mounted Duck Bill Clamp

Cat. No. & Description		Class / ASTM Grade	Main Line Range	Continuous Current Rating	Weight ea. lbs. (kgs)
<b>556 KCM SMOOTH JAW BRONZE DUCK BILL --Gravity Actuated - "V" Thread</b>					
<b>B</b> <b>R</b> <b>O</b> <b>N</b> <b>Z</b> <b>E</b>	1793 Eye	4 / A Smooth Jaw	556 MCM ACSR to #6 .96" - .16"	350 RMS Amps 60 Hz	1.3 (.6)
	w/ strain relief sleeve				
	21080 Eye				1.1 (.5)
	w/o strain relief sleeve				
	1797* Mounted				4.3 (2)
	w/ strain relief sleeve		24mm - 4mm Dia.		
	2093 Hanger Stud only				.4 (.1)
<b>1.1" SMOOTH JAW ALUMINUM DUCK BILL --Spring Loaded - "V" Thread</b>					
<b>A</b> <b>L</b> <b>U</b> <b>M</b> <b>I</b> <b>N</b> <b>U</b> <b>M</b>	21030 Eye	5 / A Smooth Jaw	795 KCM ACSR to #6 1.1" - .16"	400 RMS Amps 60 Hz	1.1 (.5)
	w/ strain relief sleeve				
	21059 Eye				1.0 (.5)
	w/o strain relief sleeve				
	21081* Mounted				4.3 (2)
	w/ strain relief sleeve		28mm - 4mm Dia.		
	21754 Hanger Stud only				.3 (.1)
<b>1.66" SERRATED JAW ALUMINUM DUCK BILL --Spring Loaded - "V" Thread</b>					
<b>A</b> <b>L</b> <b>U</b> <b>M</b> <b>I</b> <b>N</b> <b>U</b> <b>M</b>	1853 Eye	5 / B Serrated Jaw	1590 MCM ACSR to #6 1.65" - .16"	400 RMS Amps 60 Hz	1.5 (.7)
	w/ strain relief sleeve				
	2553 Eye				1.4 (.6)
	w/o strain relief sleeve				
	1855* Mounted				4.7 (2.1)
	w/ strain relief sleeve		42mm - 4mm Dia.		
	21754 Hanger Stud only				.3 (.1)

\*Mounted: 1.25" dia x 6' Fiberglass Hot Stick permanently mounted



## "C" TYPE GROUNDING CLAMPS



Cat. No. & Description		Class / ASTM Grade	Main Line Range	Continuous Current Rating	Weight ea. lbs. (kgs)	
<b>477 MCM BRONZE "C" CLAMP w/ Curved Lower Jaw - "V" Thread</b>						
<b>B R O N Z E</b>	4200 Eye	5 / A	477 MCM 18 x 1 ACSR	400 RMS Amps 60 Hz	1.1 (.5)	
	w/ strain relief sleeve					
	21067 Eye	Smooth Jaw	to		1.0 (.4)	
	w/o strain relief sleeve		#8			
	4260 Eye	5 / B	.83" - .12"			1.1 (.5)
	w/ strain relief sleeve					
	21068 Eye	Serrated Jaw	21mm - 3mm Dia.			1.0 (.4)
	w/o strain relief sleeve					
2093 Hanger Stud only				.4 (.2)		
<b>1" ALUMINUM "C" CLAMP - Acme thread</b>						
<b>A L U M I N U M</b>	2531 Eye	5 / A	795 MCM 26 x 7 ACSR	400 RMS 60 Hz	1.1 (.5)	
	w/ strain relief sleeve					
	2532 Eye	Smooth Upper Jaw	to		1.1 (.5)	
	w/o strain relief sleeve		w/		#8	
	2533* Mounted	Flat Lower Jaw				4.2 (19)
	w/ strain relief sleeve					
	4388 Eye	5 / B	1.12" - .12"			1.5 (.7)
	w/ strain relief sleeve	Smooth Upper Jaw	29mm - 3mm Dia.			
	4389 Eye	w/				1.1 (.5)
	w/o strain relief sleeve	Curved Lower Jaw				
2537 Hanger Stud only				.2 (.1)		

\*Mounted: 1.25" dia x 6' Fiberglass Hot Stick permanently mounted

## "C" TYPE GROUNDING CLAMPS

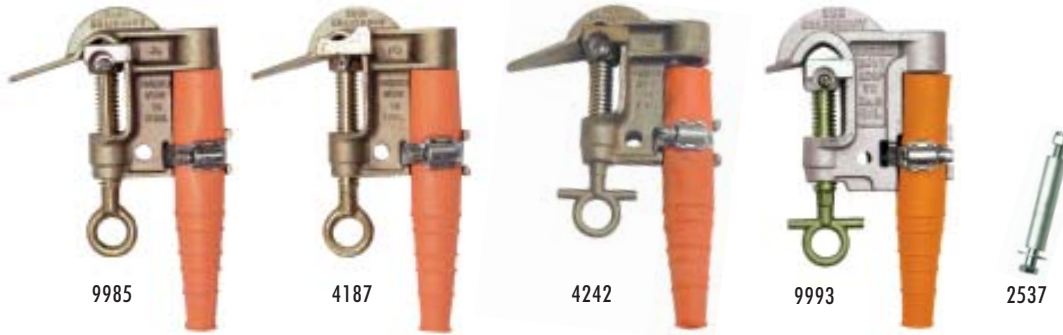

Cat. No. & Description		Class / ASTM Grade	Main Line Range	Continuous Current Rating	Weight ea. lbs. ( kgs )	
<b>1" Bronze "C" Clamp - Acme thread</b>						
<b>B R O N Z E</b>	<b>9985</b> Eye w/ strain relief sleeve	5 / A Smooth Jaw	795 MCM 26 x 7 ACSR	400 RMS Amps 60 Hz	1.9 (.9)	
	<b>2937</b> Eye w/o strain relief sleeve		to #8		1.8 (.8)	
	<b>4280*</b> Mounted w/ strain relief sleeve		1.12" - .12"		4.9 (2.2)	
	<b>4187</b> Eye w/ strain relief sleeve	5 / B Serrated Jaw	29mm - 3mm Dia.		1.9 (.9)	
	<b>2537</b> Hanger Stud only				.4 (.2)	
	<b>GRADE 5 "T" / EYE "C" CLAMP - Acme Thread</b>					
	<b>B R O N Z E</b>	<b>4242</b> "T" w/ strain sleeve & "T" eye screw	5 / A Smooth Jaw	795 MCM 26" x 7" ACSR	400 RMS Amps 60 Hz	1.9 (.9)
<b>9993</b> "T" w/ strain sleeve & "T" eye screw		to #6 1.12" - .16" 29mm - 4mm Dia.		1.6 (.7)		
<b>A L U M I N I U M</b>						

\*Mounted: 1.25" dia x 6' Fiberglass Hot Stick permanently mounted

## "C" TYPE GROUNDING CLAMPS

1.25" and 1.5" Sizes



Cat. No. & Description		Class / ASTM Grade	Main Line Range	Continuous Current Rating	Weight ea. lbs. ( kgs )	
<b>1.25" BRONZE "C" CLAMP - Acme Thread</b>						
B R O N Z E	9984 Eye	5 / A			2.2 ( 1.0 )	
	w/ strain relief sleeve	Smooth Jaw				
	1897 Eye	w/			2.1 ( .9 )	
	w/o strain relief sleeve	Flat Lower Jaw	1035.5 KCM ACSR			
	4255 Eye	5 / A	to #6	400 RMS Amps	2.2 ( 1.0 )	
	w/ strain relief sleeve	Smooth Jaw		60Hz		
	21069 Eye	w/	1.26 " - .16"		2.1 ( .9 )	
	w/o strain relief sleeve	Curved Lower Jaw				
	4279 Eye	5 / B	32mm - 4mm Dia.		2.2 ( 1.0 )	
	w/ strain relief sleeve	Serrated Jaw				
21070 Eye	w/			2.1 ( .9 )		
w/o strain relief sleeve	Flat Lower Jaw					
9983 Hanger Stud only					.4 ( .2 )	
<b>1.25" ALUMINUM "C" CLAMP - Acme Thread</b>						
A L U M I N U M	24410 Eye	5 / A	1035.5 KCM ACSR		2.2 ( 1.0 )	
	w/ strain relief sleeve	Smooth Jaw	to #6	400 RMS Amps		
		w/ Flat Lower Jaw	1.26 " - .16"	60Hz		
			32mm - 4mm Dia.			
<b>1.5" ALUMINUM "C" CLAMP, w/ flat lower jaw - Acme Thread</b>						
A L U M I N U M	1895 Eye				1.7 ( .8 )	
	w/ strain relief sleeve					
	2195 Eye		1431 KCM ACSR		1.5 ( .7 )	
	w/o strain relief sleeve	5 / B	to #6	400 RMS Amps		
	1896* Mounted	Serrated Jaw	1.5" - .16"	60 Hz	4.8 ( 2.1 )	
	w/ strain relief sleeve		to #6			
	21099 "T"		38mm - 4mm Dia.		1.7 ( .8 )	
	w/ strain relief sleeve					
	1928 Hanger Stud only					.2 ( .1 )

\*Mounted: 1.25" dia x 6' Fiberglass Hot Stick permanently mounted

**SALISBURY**

Setting industry standards since 1855. 7520 N Long Ave Skokie IL 60077 Toll Free 877.406.4501 Fax 847.679.2401

# "C" TYPE GROUNDING CLAMPS

## 2" Sizes

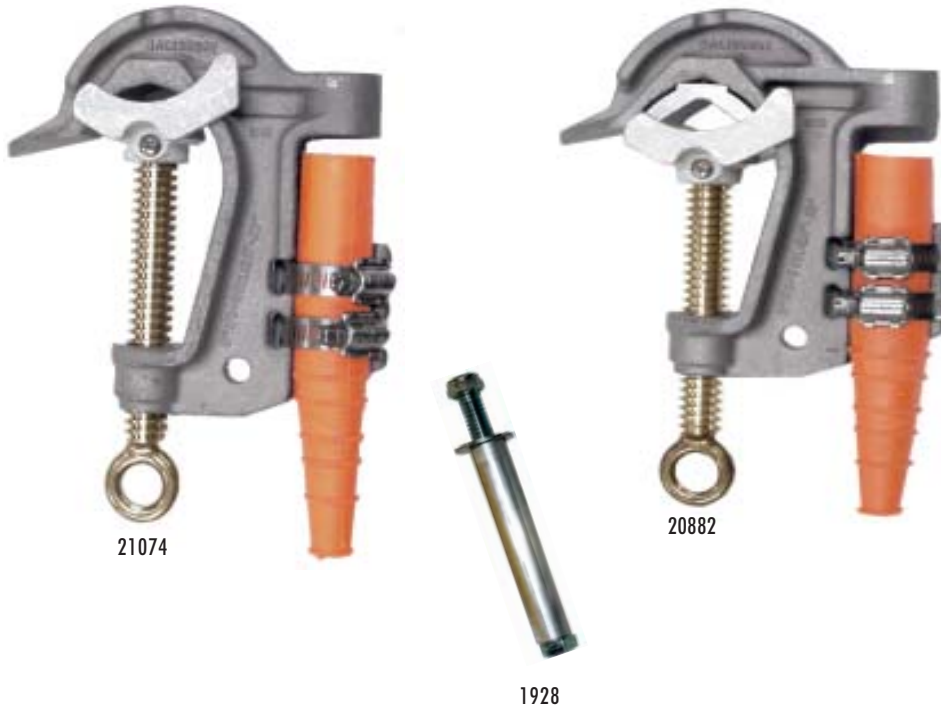

	Cat. No. & Description	Class / ASTM Grade	Main Line Range	Continuous Current Rating	Weight ea. lbs. ( kgs )
M U N I M A L	<b>2 " ALUMINUM "C" CLAMP w/ Curved Lower Jaw - Acme Thread</b>				
	<b>21074</b> Eye w/ strain relief sleeve	5 / A Smooth Jaw	3000 KCM ACSR to #6	400 RMS Amps 60 Hz	2.1 ( 1.0 )
	<b>21075</b> Eye w/o strain relief sleeve				2 ( .9 )
	<b>20882</b> Eye w/ strain relief sleeve	5 / B Serrated Jaw	2"-.16" 51mm - 4 mm		2.1 ( 1.0 )
	<b>21077</b> Eye w/o strain relief sleeve				2 ( .9 )
	<b>1928</b> Hanger Stud only				.2 ( .1 )

## "C" TYPE GROUNDING CLAMPS

### 2.4" Size



1924 - Stick Mounted "C" Type Clamp

Cat. No. & Description		Class / ASTM Grade	Main Line Range	Continuous Current Rating	Weight ea. lbs. (kgs)	
<b>2.4" ALUMINUM "C" CLAMP w/ Flat Lower Jaw - Acme Thread</b>						
ALUMINUM	1923 Eye w/ strain relief sleeve	5 / A Smooth Jaw	2.0" I.P.S. to #6	400 RMS Amps 60 Hz	2.1 (1.0)	
	4377 Eye strain relief sleeve & oval eye				2.1 (1.0)	
	4240 Eye w/o strain relief sleeve				2.0 (1.0)	
	1924* Mounted w/ strain relief sleeve				5.1 (2.3)	
	1921 Eye w/ strain relief sleeve	5 / B Serrated Jaw	2.4" - .16" 61mm - 4mm Dia.	400 RMS Amps 60 Hz	2.2 (1.0)	
	4390 Eye strain relief sleeve & oval eye				2.2 (1.0)	
	1922* Mounted w/ strain relief sleeve				5.2 (2.3)	
	1928 Hanger Stud only					
	<b>2.4" BRONZE "C" CLAMP w/ flat lower jaw - Acme Thread</b>					
	BRONZE	4295 Eye w/ strain relief sleeve	5 / A Smooth Jaw	2.0" I.P.S. to #6	400 RMS Amps 60 Hz	4.1 (1.8)
4311 Eye w/o strain relief sleeve		4.0 (1.7)				

\*Mounted: 1.25" dia x 6' Fiberglass Hot Stick permanently mounted

## GROUNDING CLAMPS FOR SUBSTATION BUSES



4282



4341



2991

Cat. No. & Description	Class / ASTM Grade	Main Line Range	Continuous Current Rating	Weight ea. lbs. (kgs)
<b>3.5" ALUMINUM "C" CLAMP for Substation Buses - Acme Thread</b>				
<b>4282</b> Eye w/ strain relief sleeve		3" - 1.5" I.P.S.		2.8 (1.3)
<b>4283*</b> Mounted w/ strain relief sleeve	5 / A Smooth Jaw	3.5" - 1.75" 89mm - 44mm Dia.	400 RMS Amps	5.8 (2.5)
<b>4341</b> Eye, strain relief sleeve & long eye screw (Main line range 3.5"-.16"(89-4mm)	w/ Flat Lower Jaw	3" I.P.S. to #6 3.5" - .16" 89mm - 4 mm Dia.	60 Hz	2.9 (1.4)
<b>6.62" ADJUSTABLE ALUMINUM " C " CLAMP for Round, Square, Rectangle or "H" Section Substation Buses - Acme Thread</b>				
<b>2991</b> Eye w/ strain relief sleeve				6.9 (3.1)
<b>2993**</b> Eye w/ single contact stud	5 / A Smooth Jaw	6.12" I.P.S.	400 RMS Amps	7.0 (3.2)
<b>9967**</b> Eye w/ double contact stud	w/ Flat Lower Jaw	6.62" - .4" 168mm - 10mm Dia.	60 Hz	7.3 (3.3)
<b>4378</b> Eye, strain relief sleeve & oval eye				6.9 (3.1)

\*Mounted: 1.25" dia x 6' Fiberglass Hot Stick permanently mounted

\*\*No Ferrule Connection

## PRESSURE TERMINAL CLAMPS

These **Duckbill** and **“C” Clamps** feature pressure terminations for use with plain ferrules. Made of high strength aluminum, with bronze eye-screws, these Grade 5 clamps are designed for smooth operation and long service life. Duckbill clamps for all grounding applications from .16 to 1.1" diameter. “C” clamps for all grounding applications from .06 to 1.26" diameter.

**Flat Jaw Grounding Clamps** are now available with pressure terminals for use with plain cable ferrules. These clamps are made of a high strength aluminum, and a bronze eye screw or “T” handle for durability and smooth operation. Also featured is a hardened aluminum alloy serrated insert. This insert is designed to grip tightly to flat surfaces and cut through surface contamination and oxidation for low resistance contact. The pressure termination is designed on an angle keeping the cable out of the way during installation. The cable termination is angled to minimize interface with the “T” handle or eye when installing or removing the clamp.

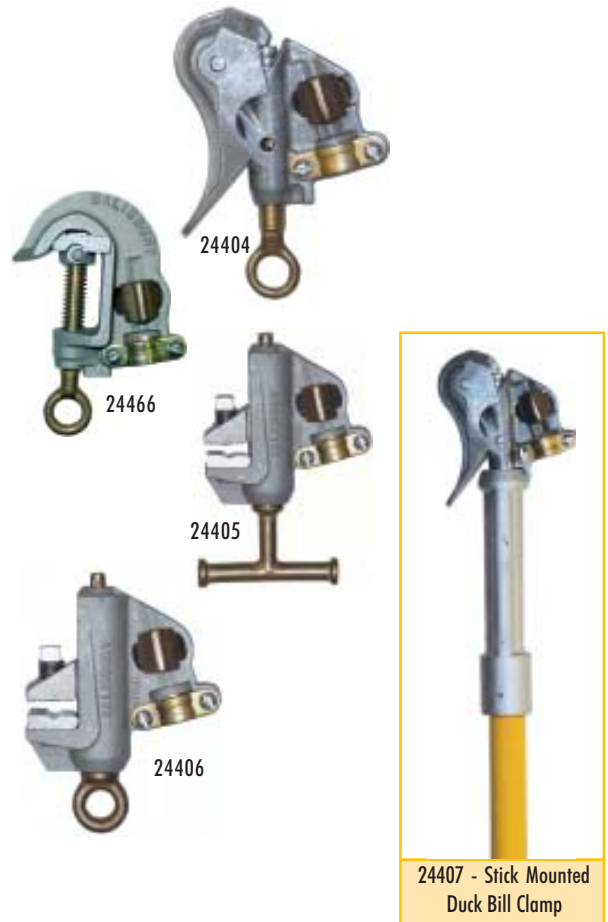

Salisbury’s **24438 Plain Ferrule 4-way Connector** is available on page H-23.

	Cat. No. & Description	Class / ASTM Grade	Main Line Range	Continuous Current Rating	Weight ea. lbs. ( kgs )
M U N I M U L A	<b>1.1" SMOOTH JAW ALUMINUM --Spring Loaded - "V" Thread</b>				
	<b>24404</b> Duckbill	5 / A Smooth Jaw	795 KCM ACSR	400 RMS Amps 60 Hz	1.5 (.68)
	Eye w/o strain relief sleeve		to #6		
			1.1" - .16" 28mm - 4mm Dia.		
	<b>1.25" SMOOTH JAW ALUMINUM --Spring Loaded - Acme Thread</b>				
	<b>24466</b> "C" Type	5 / B Serrated	1035.5 KCM ACSR	400 RMS Amps 60 Hz	2.2 (1.0)
	Eye w/o strain relief sleeve		to #6		
			1.26" - .06" 32mm - 1.5mm Dia.		
	<b>24407</b> Stick mounted duckbill clamp				4.5 (2.05)
	<b>21754</b> Hanger Stud only				.3 (.1)
<b>ALUMINUM FLAT JAW Grounding Clamp - Acme Thread</b>					
<b>24405</b> "T" screw	5 / B	1.5" - .06"	400 RMS Amps	2.1 (.9)	
no strain relief sleeve		Flat or Square			
<b>24406</b> Eye screw	Serrated Jaw	1.26" - .06"	60Hz	2.0 (.9)	
no strain relief sleeve		32 - 1.5 mm Dia.			

## GROUNDING CLAMPS

### For Flats, Angles & Rounds

**Flat Jaw Grounding Clamps** are available with either a large “T” handle or with an eye for clampstick application. The handles and eyes are designed so that the cable will not interfere with the torquing of the clamp. The set screw that secures the clamp to a flat surface is located on the movable jaw on all designs. When tightened, the set screw forces the fixed jaw of the clamp firmly against the flat ensuring a consistent low resistance current path directly through the body of the clamp to the cable connection. With other designs having a set screw on the fixed jaw, current is required to flow through mechanical connections between the movable jaw, the eye screw, and the body of the clamp before passing to the cable connection.

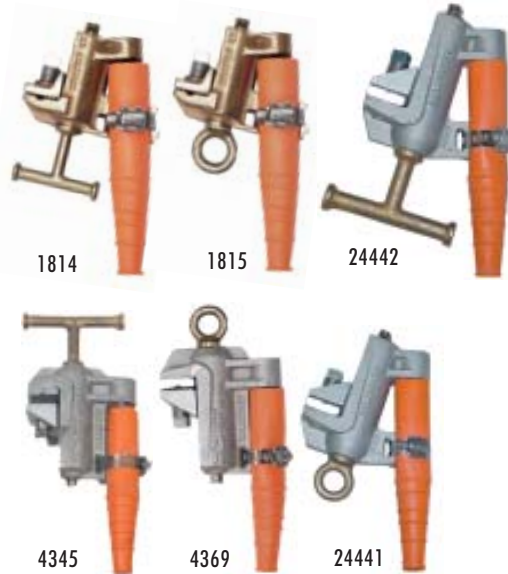

	Cat. No. & Description	Class / ASTM Grade	Main Line Range	Continuous Current Rating	Weight ea. lbs. ( kgs )	
BRONZE	<b>GRADE 3 BRONZE FLAT JAW Grounding Clamps - "V" Thread</b>					
	<b>1814</b> "T" w/ strain sleeve & "T" screw	3 / B Serrated Jaw	1.5" - .06"	300 RMS Amps 60Hz	1.7 (.8)	
	<b>1815</b> Eye w/ strain sleeve & eye screw		1.26" - .06" 32mm - 1.5 mm Dia.		1.6 (.7)	
	ALUMINUM	<b>GRADE 5 ALUMINUM FLAT JAW Grounding Clamp - Acme Thread</b>				
		<b>4345</b> "T" w/ strain sleeve & "T" screw	5 / B Serrated Jaw	1.5" - .06"	400 RMS Amps	2.1 (.9)
		<b>24442</b> "T" w/ strain sleeve & "T" screw				1.26" - .06" 32mm - 1.5 mm Dia.
<b>4369</b> Eye w/ strain sleeve & eye screw		60Hz		2.0 (.9)		
<b>24441</b> Eye w/ strain sleeve & eye screw		60Hz		2.0 (.9)		

\*Mounted: 1.25" dia x 6' Fiberglass Hot Stick permanently mounted



## GROUNDING CLAMPS FOR FLATS & ANGLES

The **Heavy Duty Bronze “C” Type Flat Jaw Clamp** with anti-blow off keeper is made to fit structural angles, flats, and copper or copperweld stranded grounding assemblies. To install, first use an abrasive cloth or wire brush to clean the surface to be clamped. Then, wipe the surface clean, position the clamp, finger tighten and set the screws. Use a wrench to secure and tighten. A 2667 clamp with contact stud offers greater versatility.

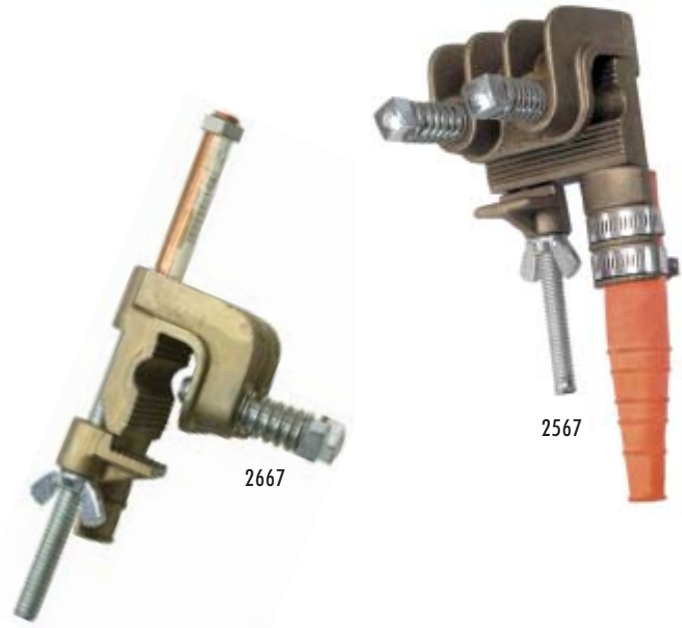

Cat. No. & Description	Class / ASTM Grade	Main Line Range	Tap Size	Weight ea. lbs. ( kgs )
<b>2567</b> w/ Strain Relief Sleeve 5/8"-11NC Connection	5 / B Serrated Jaw	Angles & Flats: 2.5"-4" WX (64-101 x 3-19mm) Rounds: .25"-.75" (6-19mm) Dia.	5/8-11UNC Max. Cable Size 4/0 Type V Compression Ferrules	4 ( 1.8 )
<b>2577</b> w/ Strain Relief Sleeve 3/4"-10NC Connection	6 / B Serrated Jaw	Angles & Flats: 2.5"-4" WX (64-101x3-19mm) Rounds: .25"-.75" (6-19mm) Dia.	3/4-10UNC Max. Cable Size 250 MCM Type V Compression Ferrules	4 ( 1.8 )
<b>2667</b> 2567 Clamp w/ Contact Stud	5 / B Serrated Jaw			5 ( 2.3 )

## BALL & SOCKET SYSTEM

### Socket Clamp

The **Ball and Socket Grounding System** allows for variable angle accessibility. This system is compact and lightweight. There are fixed grounding points on the socket clamp. The 21190 Socket Clamp, made from bronze alloy, has a socket size of 1" (25.4mm) and a threaded bore boss of 5/8"-11 UNC. The socket clamp has an integral cable support with strain relief sleeve.



21190



Cat. No. & Description	ASTM Grade	Continuous Current Rating	Weight ea. lbs. ( kgs)
21190 w/ Strain Relief Sleeve	5	400	1.2 ( .54 )
21277 w/o Strain Relief Sleeve	5	400	1.1 ( .5 )

## BALL & SOCKET SYSTEM

### Ball Studs

The **Ball Stud**, long and short, the **Offset Nema Pad Ball Stud**, and the **21846 90° Offset Nema Pad** are made from a copper alloy, tin-plated. They each have a 1" (25.4mm) diameter ball. The long and short Ball Stud have a 1/2"-13 UNC x 2" thread and a recommended installation torque of 300 in. lbs. The short stud is used conventionally. The long stud can also be used as the grounding point for "C" or Duckbill clamps that have a jaw width of 2.75" or less. The Offset Nema Pad Ball Stud has the standard Nema bolt hole spacing and also comes in both long and short lengths. The **Internal Thread Ball Stud** is tapped for a 1/2-13 UNC bolt having a length of at least 1".

The **Ball Stud Cover**, made from orange SALCOR®, allows for multiple angle application when installed using a clampstick.



Cat. No.	Description	Dimensions in. ( mm )	ASTM Grade	Weight ea. lbs. ( kgs )
21191	Ball Stud Short	4.38 ( 111 )	5	.53 ( .23 )
21192	Ball Stud Long	6.13 ( 156 )	5	.81 ( .37 )
21846	90° Offset Nema Pad	3.25 ( 83 ) x 5.75 ( 147 )	5	1 ( .45 )
24082	Internal Thread Ball Stud	4 ( 102 )	5	.54 ( .25 )
21228	Offset NEMA Pad Short	5.13 x 1.5 ( 130 x 38 )	5	.84 ( .38 )
24087	Offset NEMA Pad Long	7 x 1.5 ( 178 x 38 )	5	1 ( .45 )
21236	Cover for Ball Stud	-	n / a	.09 ( .04 )

## SPECIALTY CLAMPS

**Cutout Clamps** are applied with a clampstick into the bottom hinge contact of a cutout. This clamp can be used as part of a ground assembly or by using a contact stud using a standard grounding assembly with “C” clamps from the stud to ground.

Lightweight, heavy duty **Stringing Ground** installs anywhere along the length of conductor to provide a continuous grounding bond, even if the conductor is slack. Constructed of high-strength aluminum alloy with large diameter sheaves and bronze bushing bearings. Side opening for quick, easy installation. Adjustable compression spring assures proper contact for different sizes of conductor and for easy passage of splices. In tests, this clamp withstood a 25kA, 28 cycle short circuit. The three options for a ground tap connection are: termination for ground cables, contact/hanger stud and connector for ground wire.

The **Cable Penetrating Ground Clamp** is designed to be used either as a tool for “spiking” jacketed cable or as a part of a grounding assembly used to bond both ends of an opened cable. The 7/8” long plated steel point is inserted into the eye screw making a low resistant one piece spear. If one point becomes blunted it may be sharpened or replaced with a new spear. Clamps are aluminum body with either smooth or serrated upper jaws. The hard aluminum serrated insert makes optimum contact with the stranded neutral shield.

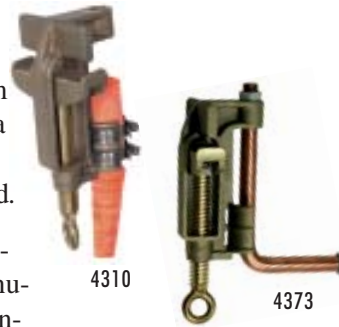

Cutout Clamp with Contact Stud

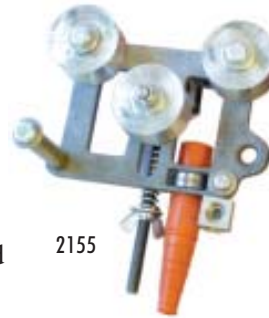

2155



Cutout Clamp Jumper Assembly



2607

	Cat. No. & Description	Class / ASTM Grade	Main Line Range	Continuous Current Rating	Weight ea. lbs. (kgs)
B R O N Z E	<b>BRONZE CUTOUT CLAMPS - "V" Thread</b>				
	<b>4310</b> Eye w/ferrule connection	5	5/8 - 11 UNC Max. Cable Size: 470	400 RMS Amps	2.1 (1.1)
	<b>4373</b> Eye w/contact stud		Type VI		3.3 (1.5)
	<b>4379</b> Contact stud only		Threaded Stud Compression Ferrule	60 Hz	1.2 (.5)
M U N I M U M	<b>STRINGING GROUND</b>				
	<b>2155</b> Stringing ground	Alloy Rollers Smooth Contacts Class A	1033.5 KCM ACSR- to #2 Sol 1.26"-.25" 32mm - 6mm Dia Splice: 1.5" (38mm) Dia	300 RMS Amps 60 HZ	5.3 (2.4)
A L U M I N I U M	<b>CABLE PENETRATING GROUND CLAMP - Acme Thread - Pointed Lower Jaw</b>				
	<b>2607</b> 1.5" Opening	Class B	-	-	1.7 (.8)
	<b>20867</b> 2.40" Opening	serrated jaw			2.2 (1)
	<b>4290</b> 2.40" Opening	Class A smooth jaw	-	-	2.1 (1)

## GROUNDING CABLES

**Grounding Cables** are made with extra flexible strand of soft drawn #30 AWG (.01") copper and are available in three different jackets.

The yellow thermoplastic elastomer jacketed cable is the standard for grounding service. It provides a combination of economy, flexibility, and durability. The service temperature ranges from 200° to -50°F per ASTM F 855, Type I requirements.

The black thermoplastic elastomer jacketed cable has a smaller diameter and thinner jacket material giving it better flexibility than the yellow cable. The service temperature ranges from 200° to -50°F per ASTM F 855, Type I requirements.

The transparent flexible thermoplastic (PVC or silicone) jacketed cable allows easy inspection for strand breakage. The flexibility decreases with low temperatures. The minimum recommended service temperature is 0°F per ASTM F 855, Type III requirements.



	Cat No.	Size	Strand Dia. in. (mm)	Jacket in. (mm)	Short Circuit Withstand		Continuous Current AMPS, RMS, 60Hz	Wt. / 1000 ft. lbs. (kgs)
					AMPS, RMS, 60Hz 15 Cycles	30 Cycles		
YELLOW	2136	#2-665W	.35 (8.9)	.5 (12.7)	14500	10000	200	282 (127)
	2137	1/0-1064W	.45 (11.4)	.62 (15.7)	21000	15000	250	488 (221)
	2138	2/0-1330W	.49 (12.4)	.65 (16.5)	27000	20000	300	537 (243)
	2139	4/0-2109W	.62 (1.7)	.83 (21.1)	43000	30000	400	836 (379)
BLACK	2636	#2-665W	.35 (8.9)	.47 (12)	14500	10000	200	263 (119)
	2637	1/0-1064W	.45 (11.4)	.58 (14.7)	21000	15000	250	404 (183)
	2638	2/0-1330W	.49 (12.4)	.63 (16)	27000	20000	300	497 (225)
	2649	3/0-1672W	.55 (14)	.72 (18.3)	36000	25000	350	680 (308)
	2639	4/0-2109W	.62 (1.7)	.78 (19.8)	43000	30000	400	770 (349)
CLEAR	2128	#2-665W	.35 (8.9)	.53 (13.5)	14500	10000	200	289 (131)
	2129	1/0-1064W	.45 (11.4)	.64 (16.3)	21000	15000	250	520 (235)
	2133	2/0-1330W	.49 (12.4)	.7 (17.8)	27000	20000	300	546 (247)
	2288	4/0-2109W	.62 (1.7)	.84 (21.3)	43000	30000	400	841 (381)
CLEAR SILICONE	21930	2/0-1330W	.49 (12.4)	.62 (15.7)	27000	20000	300	487 (221)
	21931	4/0-2109W	.62 (1.7)	.78 (19.8)	43000	30000	400	579 (263)

## THREADED GROUNDING FERRULES

Salisbury compression **Threaded Grounding Ferrules** provide low resistant connection to cable strands with a threaded stud that securely screws into a clamp. Nut and lock washers increase contact pressure and secure the assembly. Use aluminum ferrules on aluminum body clamps. Tin plated copper ferrules can be used on either bronze or aluminum body clamps. All Salisbury threaded grounding ferrules are unshrouded and manufactured with a 5/8-11 UNC threaded stud and meets the requirements of ASTM F855.



	Cat. No. Pair	ASTM Grade	Size	Installing Die Codes T&B	Burndy Die Numbers	Weight ea. lbs. ( kgs )
ALUMINUM	2026	1	#2	50	-	.2 ( .1 )
	2027	2	1/0	50	-	.2 ( .1 )
	2620	3	2/0	60	-	.3 ( .1 )
	4284	4	3/0	71	-	.3 ( .1 )
	2640	5	4/0	71	-	.3 ( .1 )
COPPER	2022	1	#2	50	U243	.5 ( .2 )
	2023	2	1/0	50	U243	.4 ( .2 )
	2024	3	2/0	60	U245	.4 ( .2 )
	4277	4	3/0	66		.6 ( .3 )
	2025	5	4/0	66	U247	.6 ( .3 )

Add suffix "A" to the catalog number when requesting a custom insulated grounding set.

## PLAIN SHROUDED & UNSHROUDED FERRULES

Plain Ferrules are designed for use with all grounding clamps that feature pressure terminal including the 1" duckbill and 1.5" flat jaw clamp.

**Copper Ferrules** are available in two different styles: unshrouded and shrouded. Shrouded ferrules are compressed on both the conductor and the jacket of the cable to reduce bending stress. Unshrouded ferrules are crimped on the conductor strands only. These ferrules are manufactured of tin plated, 99.5% pure copper.

**Aluminum Ferrules** are available in two different styles: unshrouded and shrouded. Shrouded ferrules are compressed on both the conductor and the jacket of the cable to reduce bending stress. Unshrouded ferrules are crimped on the conductor strands only.

Salisbury plain ferrules meet the requirements of ASTM F855.



plain shrouded



plain unshrouded

	Cat. No. Pair	Cable Size	Strand Die Codes T&B	Jacket Die Codes T&B	Burndy Die Number	Weight ea. lbs. ( kgs )
C O P P E R	<b>SHROUDED</b>					
	24424	#2	50	71	-	0.3 ( .14 )
	24425	1/0	50	71	-	0.35 ( .16 )
	24426	2/0	60	76	-	0.4 ( .18 )
	24427	4/0	66	106	-	0.45 ( .20 )
	<b>UNSHROUDED</b>					
	24420	#2	50	-	-	0.3 ( .14 )
	24421	1/0	50	-	U243	0.3 ( .14 )
	24422	2/0	60	-	U245	0.35 ( .16 )
	24423	4/0	66	-	U247	0.35 ( .16 )
A L U M I N U M	<b>SHROUDED</b>					
	24434	#2	50	71	-	0.1 ( .045 )
	24436	2/0	60	76	-	0.15 ( .07 )
	24437	4/0	71	106	-	0.15 ( .07 )
	<b>UNSHROUDED</b>					
	24430	#2	50	-	-	0.12 ( .54 )
	24431	1/0	50	-	-	0.12 ( .54 )
	24432	2/0	60	-	-	0.16 ( .073 )
	24433	4/0	71	-	-	0.16 ( .073 )

Add suffix "A" to the catalog number when requesting a custom insulated grounding set.

**SALISBURY**

Setting industry standards since 1855. 7520 N Long Ave Skokie IL 60077 Toll Free 877.406.4501 Fax 847.679.2401

## GROUNDING CLAMP HANGER STUDS

**Hanger Studs** are designed to be used with all “C” and Duck Bill ground clamps. Hanger Studs are used to hold one clamp of a set while the other is being installed on the de-energized line. Hanger Studs are not designed or tested to carry current.

**21754 Grounding Clamp Hanger Stud** can only be placed on clamps designed with a screw down strain relief system.

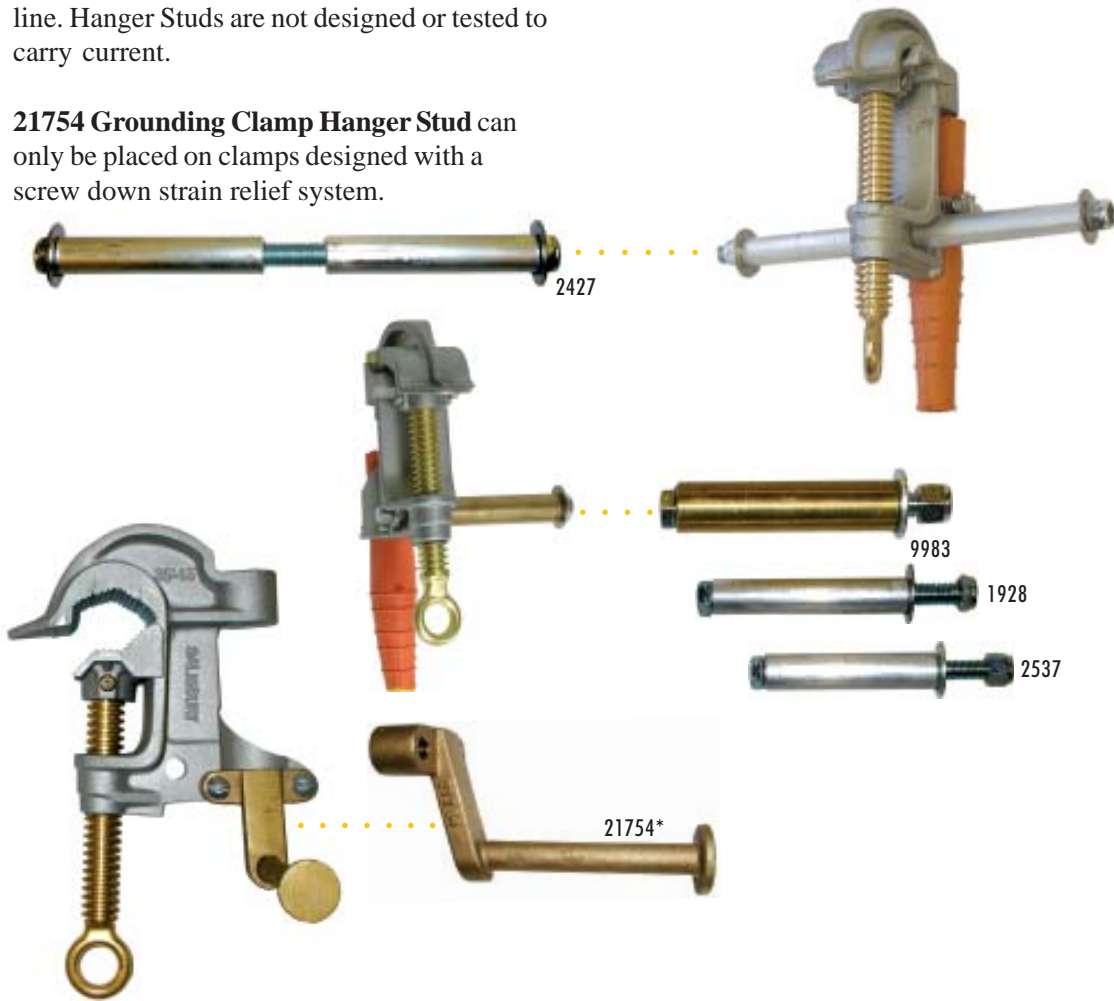

Cat. No.	Stud	For Use With	Weight ea. lbs. (kgs)
1858	Hanger	Aluminum Duck Bill 1", 1.25", 1.66"	.5 (.2)
1928	Hanger	Aluminum "C" Clamps 1.25", 1.5", 2.4", 3.5"	.5 (.2)
2427	Double Hanger	Aluminum "C" Clamps 1.25", 1.5", 2.4", 3.5"	.5 (.2)
2537	Hanger	Aluminum "C" Clamps 1"	.5 (.2)
2093	Hanger	556 Bronze Duck Bill, 477 Brz. "C"Clamp	.5 (.2)
9983	Hanger	Brass 1", 1.25", 2.4" "C"Clamps	.5 (.2)
21754*	Hanger	Bronze 1", 1.25", 2.4" "C"Clamps	.5 (.2)

**\*For use with only Plain Ferrule Clamps and Threaded Ferrule Clamps with a screw down strain relief restraint system.**



## GROUNDING ACCESSORIES

### Pole Mounted Contact Bars

are designed to act as a convenient common point for electrical connections and also as a hanger for grounding sets during installation and removal. Supplied with a chain and an adjustable wheel binder that will accommodate most common pole diameters. Catalog #20880 has one 5/8-11UNC tapped hole for the permanent connection of a ground lead. The Salisbury 21840 is a lighter-weight pole mounted contact bar.



9998



21840

The Salisbury 2103 **Screw Type Temporary Ground Rod** is used when an adequate system ground is not available. The design incorporates a copperweld rod with bronze fittings screwed and pinned on both ends. The terminal on the handle is designed to accept cables equipped with a 5/8-11 UNC threaded ferrule. As an alternative, a "C" clamp may also be attached directly to the ground rod shaft.

2103

Cat. No.	ASTM Grade	Description	Weight ea. lbs. ( kgs )
<b>POLE MOUNTED CONTACT BARS</b>			
9998	5	Contact Bar No Connection 40" Chain w/ Adjustable Wheel Binder	9.1 ( 4.1 )
21840	5	Contact Bar No Connection 40" Chain w/ Adjustable Wheel Binder	7 ( 3.3 )
20880	5	Contact Bar One Connection 40" Chain w/ Adjustable Wheel Binder	9.1 ( 4.1 )
<b>SCREW GROUND ROD</b>			
2103		75" ( 1.9m ) long	8 ( 3.6 )

## GROUNDING ACCESSORIES

**Strain Relief Sleeves** reinforce cables at the termination points when used with the cable support system. This decreases strand damage to cables from age or mishandling which reduces current carrying capacity and service life. SALCOR® Strain Relief Sleeves accept all grounding cables #2 through 4/0. Sleeve assembly consists of two parts: the inner sleeve which is discarded if the cable diameter exceeds .72" and tapered outer sleeve, 6.5" long, which can be cut to match the diameters. Clear strain relief sleeves and heat shrink are available to fit ground clamps.



Cat. No.	Description	Weight ea. lbs. ( kgs )
<b>CABLE STRAIN RELIEF SLEEVES</b>		
0786	Tapered Outer SALCOR Sleeve Only	.1 ( .04 )
1758	Inner SALCOR Sleeve Only	.1 ( .04 )
1788	Complete SALCOR Strain Relief Assembly	.1 ( .04 )
2633	Clear Sleeve for 4/0 Grounding Cable	.1 ( .04 )
2983	Clear Sleeve for #2 to 2/0 Grounding Cable	.1 ( .04 )
20886	Clear Heat Shrink, 5"( 127mm ) for All Grounding Cables	.1 ( .04 )

## CONDUCTOR & CLEANING TOOLS

**Tubular Brushes** are preferred when rubber gloving or working on de-energized conductors. The steel bristles are internal to prevent damaging rubber gloves. The 2.5" tubular brush is used in confined areas such as between two connectors or clamps.

The "V" Type **Wire Brushes** are available with epoxy coated handle or universal attachment that can be used with hot sticks. Replacement brushes are available.



Cat. No.	Description in. ( mm )	Weight ea. lbs. ( kgs )
4108	Universal Tubular	1.3 ( 0.6 )
4110	5" ( 127 ) Tubular	0.4 ( 0.2 )
4111	Universal "V" Line Cleaner	1 ( 0.5 )
4112	"V" Type handle w/ brushes	1.2 ( 0.6 )
4113	"V" Type carton of 10 replacement brushes	3 ( 1.4 )
4337	2.5" ( 63.5 ) Tubular	0.2 ( 0.1 )

# SINGLE GROUNDING ASSEMBLIES

## Single Grounding Assemblies & Sets

Salisbury offers a variety of single grounding assemblies. These single ground assemblies offer versatility to the user when performing temporary grounding.

For ordering convenience, completed **Single Grounding Assemblies** are listed which cover many standard application needs. Modification to these sets to meet specific needs can be made. Contact your local Salisbury representative for assistance or visit [www.whsalisbury.com/configurator/](http://www.whsalisbury.com/configurator/) to use our helpful online grounding configurator.



24309

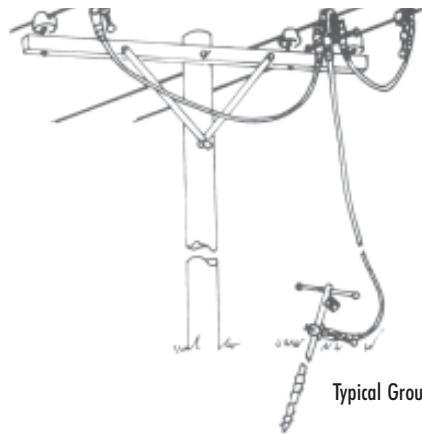

Typical Ground Cluster Set

Cat. No.	Description	ASTM Grade	Weight ea. lbs. (kgs)
<b>SINGLE GROUNDING ASSEMBLIES</b>			
24309	2 ea. #1895 Serrated Aluminum "C" Clamp 1.5" 1 pr. #2024 Ferrules 6 ft. #2138 2/0 Cu. Cable yellow	2	5.9 (2.7)

## SINGLE GROUNDING ASSEMBLIES

### Single Grounding Assemblies & Sets

Cat. No.	Description	ASTM Grade	Weight ea. lbs. ( kgs )
<b>SINGLE GROUNDING ASSEMBLIES</b>			
2299	2 ea. #1895 Serrated Aluminum "C" Clamp 1.5" 1 ea. #1928 Hanger Stud, 1 pr. #2027 Ferrules 6 ft. #2137 1/0 Cu. Cable	2	5.9 ( 2.7 )
2319	2 ea. #1923 Smooth Aluminum "C" Clamp 2.4" 1 ea. #1928 Hanger Stud, 1 pr. #2620 Ferrules 10 ft. #2138 2/0 Cu. Cable	3	8.7 ( 3.9 )
2320	1 ea. #1923 Smooth Aluminum "C" Clamp 1 ea. #4345 Aluminum Flat Jaw "T" Handle Clamp 1 pr. #2620 Ferrules, 15 ft. #2138 2/0 Cu. Cable	3	7.4 ( 3.4 )
2321	2 ea. #1793 Bronze Duck Bill 556 KCM 1 ea. #2093 Hanger Stud, 1 pr. #2023 Ferrules 6 ft. #2137 1/0 Cu. Cable	2	5.4 ( 2.5 )
2329	2 ea. #1921 Serrated Aluminum "C" Clamp 2.4" 1 ea. #1928 Hanger Stud, 1 pr. #2620 Ferrules 10 ft. #2138 2/0 Cu. Cable	3	9 ( 4.1 )
2556	2 ea. #1852 Smooth Aluminum Duck Bill Clamp 1.66" 1 ea. #1858 Hanger Stud, 1 pr. #2027 Ferrules 6 ft. #2137 1/0 Cu. Cable	2	5.2 ( 2.4 )
2558	2 ea. #1853 Serrated Aluminum Duck Bill Clamp 1.25" 1 ea. #1858 Hanger Stud, 1 pr. #2027 Ferrules 6 ft. #2137 1/0 Cu. Cable	2	5.5 ( 2.5 )
2876	2 ea. #2531 Smooth Aluminum "C" Clamp 1.0" 1 ea. #2537 Hanger Stud, 1 pr. #2027 Ferrules 6 ft. #2137 1/0 Cu. Cable	2	4.9 ( 2.2 )
9975	2 ea. #9985 Smooth Bronze "C" Clamp 1.0" 1 ea. #9983 Hanger Stud, 1 pr. #2023 Ferrules 6 ft. #2137 1/0 Cu. Cable	2	6.9 ( 3.1 )
9982	2 ea. #9984 Smooth Bronze "C" Clamp 1.25" 1 ea. #9983 Hanger Stud, 1 pr. #2023 Ferrules 6 ft. #2137 1/0 Cu. Cable	2	8.3 ( 3.7 )

## GROUNDING SETS

### Single Point Distribution Grounding Set

This **Single Point Distribution Grounding Set** creates an equal potential zone on the working structure. This is accomplished by bonding all conductors and the structure to a ground source using individual assemblies as shown in the adjacent drawing.

Going from either the ground rod or the system ground to the pole mounted contact bar under the worker's feet, to the assemblies bonding the conductors creates an equal potential zone.

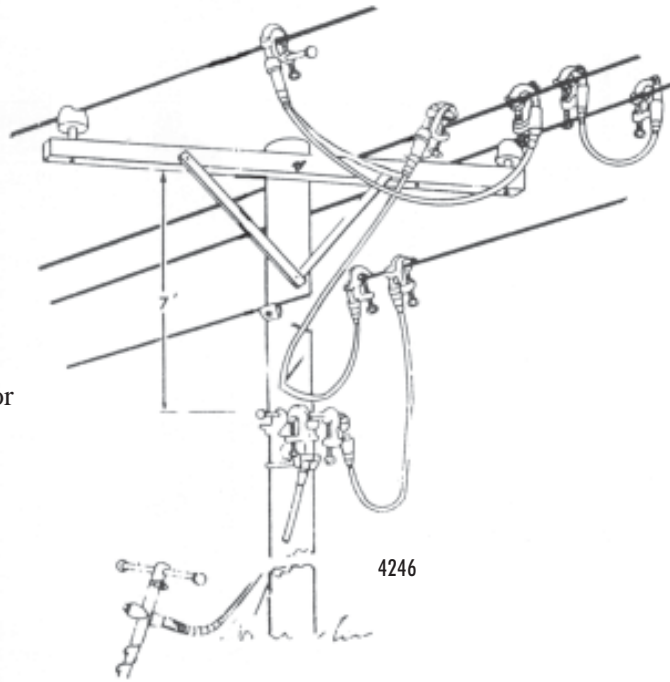

Cat. No.	Description	ASTM Grade	Weight ea. lbs. (kgs)
4246	Complete Distribution Grounding Set 10 ea. #2531 Smooth Aluminum "C" Clamps 795 KCM 1 ea. #9998 Aluminum Pole Mount Contact Bar 5 pr. #2026 Ferrules 3 ea. #2537 Hanger studs 60 ft. #2636 # Cu. Cable 1 ea. #2103 Screw Ground Rod w/ Connector	1	45.5 (20.6)

Additional Single Point Sets are available. Contact your local Salisbury representative.

## GROUNDING SETS

### 3 Wire Universal Grounding Clusters & Sets

**Grounding Clusters** are used to make it easy for a single line worker to apply multiple grounding assemblies on a three phase system. All clusters have an option of a ground lead by using the extra connection point on each cluster. Three wire clusters are recommended for three phase Delta systems. Complete grounding cluster assemblies are available from the factory. Specify cable size and length required and assembly will be made to your specifications.

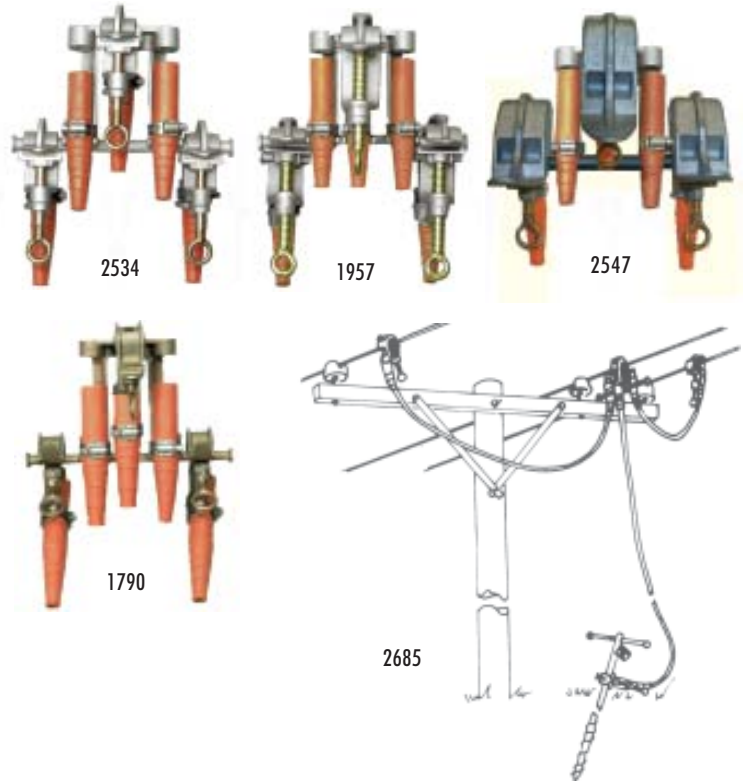

Cat. No.	Description	ASTM Grade	Weight ea. lbs. ( kgs )
1790	Cluster w/ 3 #1793 Smooth Jaw 556 KCM Bronze Duck Bill Clamps	4	6 ( 2.7 )
1957	Cluster w/ 3 #1895 Serrated Jaw 1.5" Aluminum "C" Clamps	5	6.4 ( 2.9 )
2534	Cluster w/ 3 #2531 Smooth Jaw 1" Aluminum "C" Clamps	5	4.9 ( 2.2 )
2547	Cluster w/ 3 #1853 Serrated Jaw 1.66" Aluminum Duck Bill Clamps	5	5.4 ( 2.5 )
2685	Assembled Ground Cluster Set 1 ea. #2516 Serrated Aluminum "C" Clamp 1.25" Cluster 74 ft. #2637 1/0 Cu. Cable 3 pr. #2027 Ferrules, 1 ea. #2103 Screw Ground Rod 1 ea. #2654 Storage Bag	2	54.2 ( 24.6 )
4248	Assembled Ground Cluster Set 1 ea. #1790 Smooth Bronze Duck Bill Cluster 76 ft. #2636 #2 Cu. Cable 3 pr. #2022 Ferrules, 1 ea. #2103 Screw Ground Rod 1 ea. #2654 Storage Bag	1	54.2 ( 24.6 )

Clusters are also available with Mounted Clamps, consult the factory for more information.

**SALISBURY**

Setting industry standards since 1855. 7520 N Long Ave Skokie IL 60077 Toll Free 877.406.4501 Fax 847.679.2401

## GROUNDING SETS

### 4 Wire Universal Grounding Clusters & Sets

**Grounding Clusters** are used to make it easy to apply multiple grounding assemblies easy for a single line worker. All clusters have an option of a ground lead by using the extra connection point on each cluster. Four wire clusters are recommended for three phase Wye systems. Complete grounding cluster assemblies are available from the factory. Specify cable size and length required and assembly will be made to your specifications.

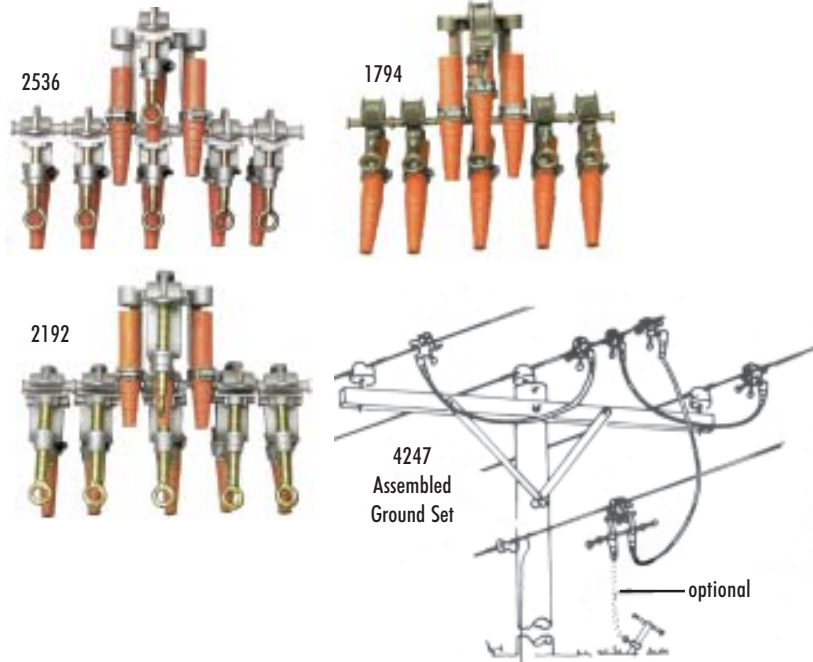

Cat. No.	Description	ASTM Grade	Weight ea. lbs. (kgs)
1794	Cluster w/ 6 #1793 Smooth Jaw 556 KCM Bronze Duck Bill Clamps	4	9 (4.1)
2192	Cluster w/ 6 #1895 Serrated Jaw 1.5" Aluminum "C" Clamps	5	11.8 (5.4)
2536	Cluster w/ 6 #2531 Smooth Jaw 1" Aluminum "C" Clamps	5	8.8 (4)
2604	Cluster w/ 6 #1853 Serrated Jaw 1.66" Aluminum Duck Bill Clamps	5	6.2 (2.8)
2682	Assembled Ground Cluster 1 ea. #1794 Smooth Bronze Duck Bill Cluster 18 ft. #2636 #2 Cu. Cable 3 pr. #2022 Ferrules 1 ea. #2654 Storage Bag	1	14.5 (6.6)
4247	Assembled Ground Cluster 1 ea. #2536 Smooth Aluminum "C" Cluster 18 ft. #2637 1/0 Cu. Cable 3 pr. #2027 Ferrules 1 ea. #2654 Storage Bag	2	18 (8.2)

Clusters are also available with Mounted Clamps, consult the factory for more information.



## GROUNDING SETS

### 4 Way Connector

The **2680 4 way connector** ground set provides an excellent system for the grounding of a 3 phase system.

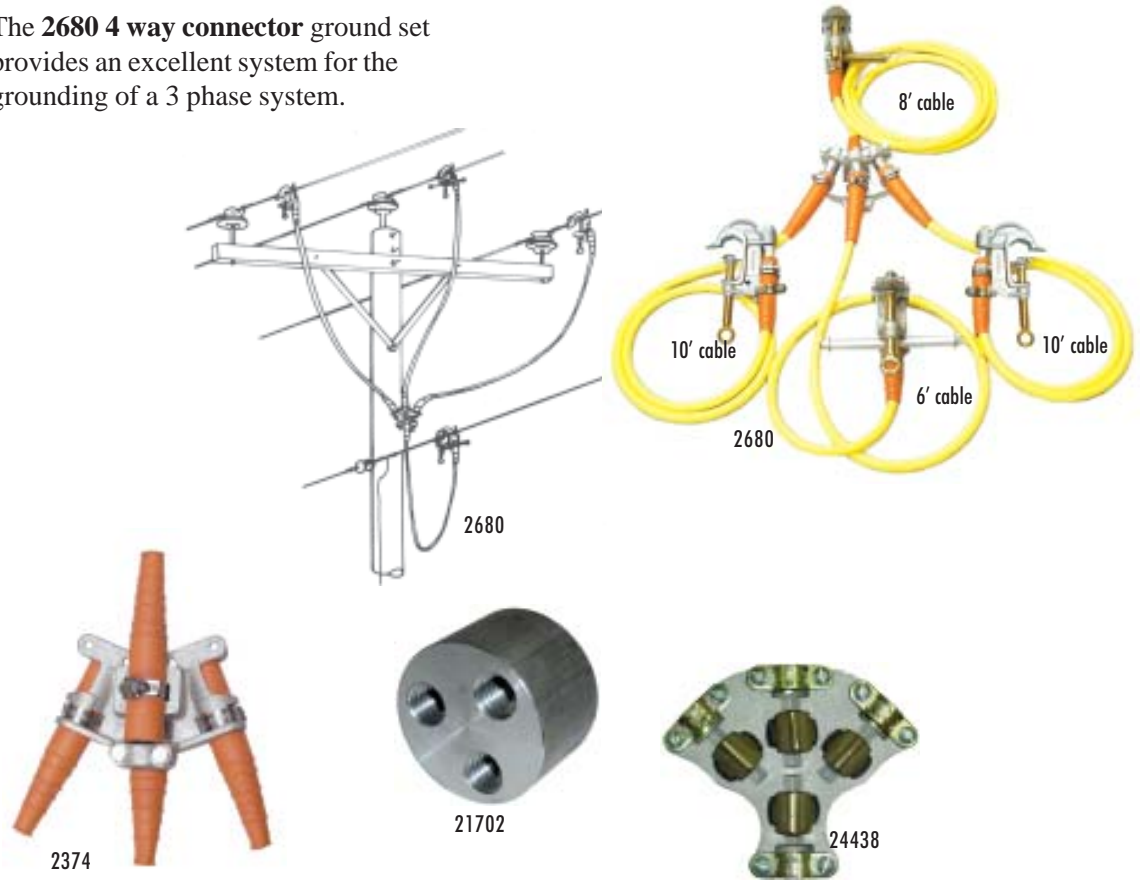

Cat. No.	Description	ASTM Grade	Weight ea. lbs. (kgs)
2680	Four Way Connector Ground Set - Grade 2 21 kA 15 cycles 1 #2374 Four Way Connector w/ Sleeves 4 #1895 1.5" Serrated Jaw Clamps w/ Sleeves 1 #2427 Double Hanger Stud, 1 #2402 Contact Stud 34 ft. #2137 1/0 Cu. Cable 4 pr. #2027 Ferrules	5	28 (12.7)
2374	Threaded Ferrule Four Way Connector	5	1.8 (.8)
21702	Threaded Ferrule Four Way Connector 1 3/4 long x 2 1/4 dia.	5	.5 (.23)
24438	Plain Ferrule Four Way Connector	5	2 (.9)

## GROUNDING SETS

### For Special Applications

Listed are some typical complete personal protection ground sets for common line construction. These sets, although practical for many applications, are shown as a guide to help determine individual system needs and for ease of ordering. Variations of these sets may be requested to meet specific situations or user preferences. Your local Salisbury representative can answer any questions you have on personal protection grounding needs and applications.

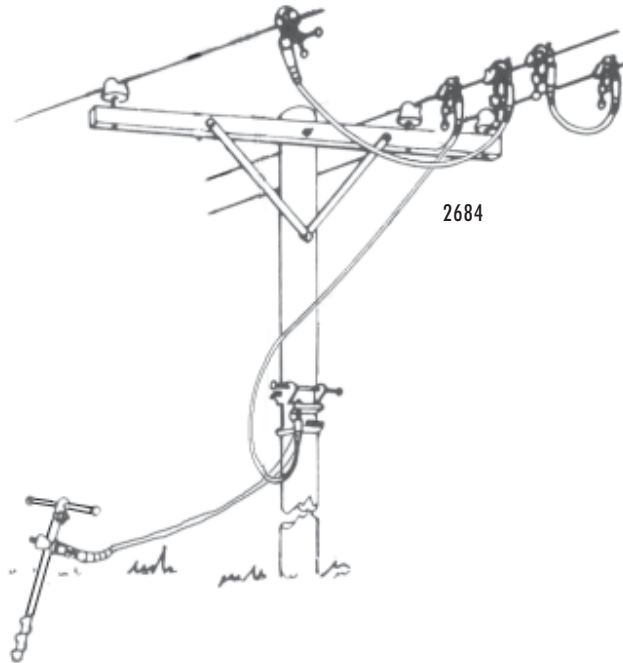

Cat. No.	Description	ASTM Grade	Weight ea. lbs. (kgs)
<b>COMPLETE 3 PHASE DELTA</b>			
2684	2 ea. #20880 Contact Bar 7 ea. #1895 Serrated Aluminum "C" Clamp 1.5" 84 ft. #2637 1/0 Cu. Black Cable, 4 pr. #2027 Ferrules 2 ea. #1928 Hanger Studs, 1 ea. #2654 Storage Bag 1 ea. #2103 Screw Ground Rod	2	63.5 (28.8)
4249	2 ea. #20880 Contact Bar 7 ea. #2531 Smooth Aluminum "C" Clamp 795 KCM 86 ft. #2637 1/0 Cu. Cable, 4 pr. #2027 Ferrules 2 ea. #2537 Hanger Studs, 1 ea. #2654 Storage Bag 1 ea. #2103 Screw Ground Rod	2	63.5 (28.8)
<b>COMPLETE 4 WIRE WYE</b>			
4276	1 ea. #20880A Contact Bar 7 ea. #2531 Smooth Aluminum "C" Clamp 795 KCM 32 ft. #2637 1/0 Cu. Cable, 4 pr. #2027 Ferrules 3 ea. #2537 Hanger Studs, 1 ea. #2654 Storage Bag	2	34 (15.4)

## GROUNDING SETS

### Dead Front Grounding Jumpers & Elbows

**Dead Front Ground Sets** are supplied with an insulated grounding elbow, yellow jacketed copper grounding cable, and a 1815 bronze flat jaw ground clamp for the ground connection. **Grounding Elbows** are equipped with arc quenching tips as provided on standard load break elbows.

Both 15kV and 25kV elbows are available with connectors for 1/0 or 2/0 cable. Assembled sets for 15kV and 25kV are available for single phase or three phase grounding requirements. Standard three phase sets have a 4 ft. tail connecting to a 2374 four wire connector with 2 ft. leads for the elbows. Sets can be factory assembled to customer specifications.

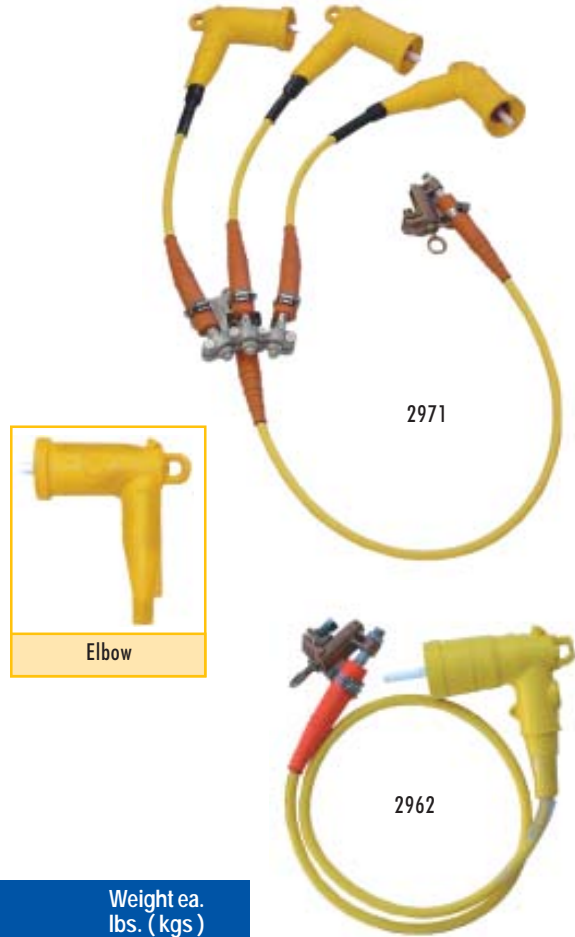

Cat. No.	Description	Weight ea. lbs. ( kgs )
<b>INSULATED GROUNDING ELBOWS</b>		
2910	15kV Elbow w/ 1/0 Cable Connector	1.7 ( .7 )
2912	15kV Elbow w/ 2/0 Cable Connector	1.7 ( .7 )
2935	25kV Elbow w/ 1/0 Cable Connector	2 ( .9 )
2936	25kV Elbow w/ 2/0 Cable Connector	2 ( .9 )
<b>ASSEMBLED GROUNDING SETS</b>		
2961	15kV Single Phase, 6 ft. 1/0 Cable w/ Bag	10 ( 4.5 )
2962	15kV Single Phase, 6 ft. 1/0 Cable w/o Bag	8 ( 3.6 )
2963	15kV Three Phase, 1/0 Cable w/ Bag	22 ( 10 )
22630	15kV Three Phase, 1/0 Cable w/o Bag	20 ( 9 )
2971	25kV Single Phase, 6 ft. 1/0 Cable w/ Bag	13 ( 5.9 )
22631	25kV Single Phase, 6 ft. 1/0 Cable w/o Bag	11 ( 5 )
2973	25kV Three Phase, 1/0 Cable w/ Bag	24 ( 10.9 )
22632	25kV Three Phase, 1/0 Cable w/o Bag	22 ( 10 )

**ASTM F855-04 Table 1 - Protective Grounding Clamp Ratings**

Grade	Grounding Clamp Torque Strength, min				Short Circuit Properties <sup>A</sup>								Continuous Current Rating, A RMS, 60 Hz	Minimum Cable Size with Ferrule Installed Equal or Larger Than
	Yield <sup>B</sup>		Ultimate		Withstand Rating, Symmetrical kA RMS, 60 Hz			Ultimate Rating/Capacity, <sup>C,D</sup> Symmetrical kA RMS, 60 Hz						
	15 cycles (250 ms)	30 cycles (500 ms)	Copper Cable Size	6 cycles (100 ms)	15 cycles (250 ms)	30 cycles (500 ms)	60 cycles (1 s)	Maximum Copper Test Cable Size						
	lbf-in.	n-m	lbf-in.	n-m										
1	280	32	330	37	14	10	#2	29	18	13	9	2/0	200	#2
2	280	32	330	37	21	15	1/0	47	29	21	14	4/0	250	1/0
3	280	32	330	37	27	20	2/0	58	37	26	18	4/0	300	2/0
4	330	37	400	45	34	25	3/0	74	47	33	23	250 kcmil	350	3/0
5	330	37	400	45	43	30	4/0	94	59	42	29	250 kcmil	400	4/0
6	330	37	400	45	54	39	250 kcmil or 2 2/0	111	70	49	35	350 kcmil	450	250 kcmil or 2 2/0
7	330	37	400	45	74	54	350 kcmil or 2 4/0	155	98	69	48	550 kcmil	550	350 kcmil or 2 4/0

<sup>A</sup> Withstand and ultimate short circuit properties are based on performance with surges not exceeding 20 % asymmetry factor (see 9.1 and 12.3.4.2).  
<sup>B</sup> Yield shall mean no permanent deformation such that the clamp cannot be reused throughout its entire range of application.  
<sup>C</sup> Ultimate rating represents a symmetrical current which the clamp shall carry for the specified time.  
<sup>D</sup> Ultimate values are based upon application of Onderdonk's equation to 98 % of nominal circular mil area allowed by Specifications B 172 and B 173.

**ASTM F855-04 Table 2 - Grounding Cable Ferrule and Assembly Ratings**

Grade	Cable Size	Short Circuit Properties <sup>A</sup> —Symmetrical kA RMS 60 Hz						Continuous Current Rating, RMS 60 Hz
		Withstand Rating			Ultimate Rating/Capacity <sup>B,C</sup>			
		15 cycles (250 ms)	30 cycles (500 ms)	6 cycles (100 ms)	15 cycles (250 ms)	30 cycles (500 ms)	60 cycles (1 s)	
1	2	14	10	28	18	13	9	200
2	1/0	21	15	47	29	21	14	250
3	2/0	27	20	59	37	26	18	300
4	3/0	34	25	74	47	33	23	350
5	4/0	43	30	94	59	42	29	400
6	250 kcmil	54	39	111	70	49	35	450
7	350 kcmil	74	54	155	98	69	49	550

<sup>A</sup> Withstand and ultimate short circuit properties are based on performance with surges not exceeding 20 % asymmetry factor (see 9.1 and 12.3.4.2).  
<sup>B</sup> Ultimate rating represents a symmetrical current which the ferrule shall carry for the time specified.  
<sup>C</sup> Ultimate value based upon application of Onderdonk's equation to 98 % of nominal circular mil area allowed by Specifications B 172 and B 173.

# VOLTAGE DETECTORS



## VOLTAGE DETECTORS

### Self Testing Audio / Visual

#### THE SALISBURY ADVANTAGE

Salisbury's **Self-Testing Voltage Detectors** allow testing to be continuous and automatic. An intermittent flash and beep confirms the detector is functioning properly.

**Self-Testing Voltage Detectors** are used to verify live or de-energized conductors. These testers may be used with rubber insulating gloves or hot sticks using the splined universal end fitting. Testers indicate the presence of voltage with an extra bright LED light and a distinctive audible signal. It is recommended that the tester be moved closer to the conductor until a warning is indicated, or it touches the conductor, apparatus, or elbow test point. Each tester requires three "C" batteries (included).



#### WARNING

Do not assume conductors are dead or will remain de-energized. Always install proper grounding devices before working.

Cat. No.	Dimensions in. ( mm )	Settings phase to phase	Weight ea. lbs. ( kgs )
4544	11 x 3.5 ( 279.4 x 89 )	Off / 240V / 4.2kV / 15kV/25kV/35kV/69kV/115kV/230kV	15oz. ( .43 )
4644	11 x 3.5 ( 279.4 x 89 )	Off / 240V / 4.2kV / 35kV/69kV/115kV/230kV/345kV/500kV	15oz. ( .43 )
4744	11 x 3.5 ( 279.4 x 89 )	Off / Test-240V / Battery / URD:15kV/25kV/35kV Overhead: 4.2kV / 15kV/25kV/35kV/46kV/69kV	15oz. ( .43 )
<b>COMPLETE KIT</b>			
4556	1-4544 Tester 240V to 230kV, 1-4315 Case, 1-2500 Shotgun Adapter		2 ( .91 )
4667	1-4644 Tester 240V to 500kV, 1-4315 Case, 1-2500 Shotgun Adapter		2 ( .91 )
4769	1-4744 Tester 240V to 69kV, 1-4315 Case, 1-2500 Shotgun Adapter		2 ( .91 )
4315	12 x 8 x 4.5 ( 305 x 203 x 114 )	Storage Case	1 ( .45 )
2500		Shotgun Adapter	.4 ( .2 )

# VOLTAGE DETECTORS

## Audio / Visual

**Voltage Detectors** are used to verify live or de-energized conductors. These testers may be used with rubber insulating gloves or hot sticks using the splined universal end fitting. Testers indicate the presence of voltage with an extra bright LED light and a distinctive audible signal. It is recommended that the tester be moved closer to conductor until warning is indicated, or it touches conductor, apparatus, or test point. Test the unit on a nearby energized conductor. Each tester requires three “C” batteries (included).



The **4445 Voltage Detector Tester** provides the most convenient and reliable means of verifying operation of Salisbury Voltage Detectors. The tester features instant push-button operation and requires a standard 9-volt battery (included). It's portable and lightweight. To operate, push the button and move the tester toward the voltage detector being verified. The tester generates an electric field that activates the detector verify-  
ing the audible and visual signals are operational.

Test Procedures		WARNING	
<p><b>Test Procedures</b></p> <p>To assure unit is in operable condition switch tester into "Test-240V" position. The tester may now be tested in several different ways.</p> <ol style="list-style-type: none"> <li>1. Place head as marked against live wire outlet or equivalent above 110V A.C.</li> <li>2. Rub the head as marked on cloth or clothing to obtain static charge. Unit will only indicate intermittently.</li> </ol>		<p><b>Do not assume conductors are dead or will remain de-energized. Always install proper grounding devices before working.</b></p>	
Cat. No.	Dimensions in. ( mm )	Settings phase to phase	Weight ea. lbs. ( kgs )
4244	11 x 3.5 ( 279.4 x 89 )	Off / 240V / 4.2kV / 15kV/25kV/35kV/69kV/115kV/230kV	15oz. (.43)
4344	11 x 3.5 ( 279.4 x 89 )	Off / 240V / 4.2kV /35kV/69kV/115kV/230kV/345kV/500kV	15oz. (.43)
4444	11 x 3.5 ( 279.4 x 89 )	Off / Test-240V / Battery / URD:15kV/25kV/35kV Overhead: 4.2kV / 15kV/25kV/35kV/46kV/69kV	15oz. (.43)
<b>COMPLETE KIT</b>			
4356	1-4244 Tester 240V to 230kV, 1-4315 Case, 1-2500 Shotgun Adapter		2 ( .91 )
4367	1-4344 Tester 240V to 500kV, 1-4315 Case, 1-2500 Shotgun Adapter		2 ( .91 )
4469	1-4444 Tester 240V to 69kV, 1-4315 Case, 1-2500 Shotgun Adapter		2 ( .91 )
4445	Voltage Detector Tester		1 ( .45 )
4315	12 x 8 x 4.5 ( 305 x 203 x 114 )	Storage Case	1 ( .45 )
2500	Shotgun Adapter		.4 ( .2 )

**HOT STICKS & TOOLS**





## FIBERGLASS HOT STICKS

### Standard Specifications

There are a variety of Fiberglass Reinforced Plastic (FRP) constructions used for hot sticks. Included are foam filled tubular sticks used for all products requiring solid construction. All Salisbury fiberglass sticks meet ASTM F711 Standard Specifications for FRP and tube used in live line tools and IEC 855.

Foam filled hot sticks are manufactured using the pultrusion process. This method incorporate fiberglass reinforcement in a resin matrix which creates a moisture resistant laminate with excellent electrical and mechanical properties.

Hot stick production is 100% electrically proof tested. Hot Stick blanks must conform with ASTM F711 requirements.



Foam Filled Hot Stick

Live Line Work Minimum Approach Distance		
Nominal Voltage kV	Exposure Distance ft.-in ( m )	
	Phase to Ground	Phase to Phase
.05 to 1	avoid contact	avoid contact
1.1 to 15	2-1 ( .64 )	2-2 ( .66 )
15.1 to 36	2-4 ( .72 )	2-7 ( .77 )
36.1 to 46	2-7 ( .77 )	2-10 ( .85 )
46.1 to 72.5	3-0 ( .9 )	3-6 ( 1.05 )
72.6 to 121	3-2 ( .95 )	4-3 ( 1.29 )
138 to 145	3-7 ( 1.09 )	4-11 ( 1.5 )
161 to 169	4-0 ( 1.22 )	5-8 ( 1.71 )
230 to 242	5-3 ( 1.59 )	7-6 ( 2.27 )
345 to 362	8-6 ( 2.59 )	12-6 ( 3.8 )
500 to 550	11-3 ( 3.42 )	18-1 ( 5.5 )
765 to 800	14-11 ( 4.53 )	26-0 ( 7.91 )

- These distances take into consideration the highest switch surge an employee will be exposed to on any system with air as the insulating medium and the maximum voltage shown.  
-The clear live-line total distances shall equal or exceed the values for the indicated voltage ranges.

## FRP CLAMPSTICKS

**Tough Thermoplastic head ferrule.**  
**EZ Grip plastic hand grip.**  
**Wide opening 15/16" ( 23.8mm)**  
**stainless steel hook.**  
**Heavy duty rubber end cap.**

**External Rod Clampsticks** are constructed of closed cell foam-filled tubular fiberglass in accordance with ASTM standard F711. The hook's operating rod, made of solid 3/8" ( 9.5mm) dia. fiberglass, is mounted on the exterior of the tool so that it can be easily wiped down prior to use.

These Clampsticks meet ASTM F1825 Standards.

Cat. No.	Length		Weight ea.	
	Feet	Meters	lbs.	kgs
<b>EXTERNAL ROD CLAMPSTICK</b>				
4007	4' 8"	1.32	4.2	1.9
4008	5' 8"	1.62	4.6	2.1
4009	6' 8"	1.93	5.2	2.4
4010	8' 8"	2.54	6.2	2.8
4011	10' 8"	3.15	7.0	3.2
4012	12' 8"	3.76	7.7	3.5
4013	14' 8"	4.37	9.4	4.3

Add a "9864" suffix for a Switch Stick Head or a "9840" suffix for a Splined Universal Head. Clamp sticks may be ordered with these fittings attached to the end by adding the appropriate suffix to the catalog number.



Side Opening Hook



9840 Splined Universal Head



External Rod Clampstick

## UNIVERSAL SWITCH STICKS

One, two, and three section hot sticks have a standard splined universal head. 1.25" dia. switch sticks are supplied with a #9971 Prong. A Heavy Duty Disconnect Prong #9969 is supplied on all others.



9969 Prong



9971 Prong

Cat. No.	Dimensions: Dia. x Length				Weight ea.			
	in x ft.		mm x m		lbs.	kgs		
<b>ONE SECTION</b>								
4213	1.25 x 4		31.7 x 1.2		2.6	1.2		
4214	1.25 x 6		31.7 x 1.8		3.4	1.5		
4215	1.25 x 8		31.7 x 2.4		4.1	1.9		
4216	1.25 x 10		31.7 x 3		4.9	2.2		
4217	1.25 x 12		31.7 x 3.6		5.6	2.5		
4218	1.25 x 14		31.7 x 4.3		6.4	2.9		
4219	1.5 x 8		38.1 x 2.4		5.4	2.5		
4220	1.5 x 10		38.1 x 3		6.5	3		
4221	1.5 x 12		38.1 x 3.6		7.5	3.4		
4222	1.5 x 14		38.1 x 4.3		8.6	3.9		
4223	1.5 x 16		38.1 x 4.9		9.8	4.3		
4225	1.5 x 20		38.1 x 6		11.7	5.3		
<b>TWO SECTIONS</b>								
	OAL Length		Top		Bottom		lbs.	kgs
	ft.	m	in. x ft.	mm x m	in. x ft.	mm x m		
4036	8	2.4	1.25 x 4	31.7 x 1.2	1.25 x 4	31.7 x 1.2	4.2	1.9
4037	10	3	1.25 x 5	31.7 x 1.5	1.25 x 5	31.7 x 1.5	5.2	2.2
4038	12	3.6	1.25 x 6	31.7 x 1.8	1.5 x 6	38.1 x 1.8	6.9	3.1
4039	14	4.3	1.25 x 6	31.7 x 1.8	1.5 x 8	38.1 x 2.4	7.9	3.1
4040	16	4.9	1.25 x 8	31.7 x 2.4	1.5 x 8	38.1 x 2.4	8.6	3.9
4041	18	5.5	1.25 x 8	31.7 x 2.4	1.5 x 10	38.1 x 3	9.6	4.4
4042	20	6	1.25 x 10	31.7 x 3	1.5 x 10	38.1 x 3	10.4	4.7
<b>THREE SECTION</b>								
	OAL Length		Top		Middle/Bottom		lbs.	kgs
	ft.	m	in x ft.	mm x m	in. x ft.	mm x m		
4043	12	3.6	1.25 x 4	31.7 x 1.2	1.5 x 4	38.1 x 1.2	7.7	3.5
4044	15	4.6	1.25 x 5	31.7 x 1.5	1.5 x 5	38.1 x 1.5	9.1	4.1
4045	18	5.5	1.25 x 6	31.7 x 1.8	1.5 x 6	38.1 x 1.8	10.5	4.7
4046	20	6	1.25 x 8	31.7 x 2.4	1.5 x 6	38.1 x 1.8	16.5	7.5
<b>HEAD ONLY</b>								
9840			1.25	31.7	Universal Head		0.2	0.1
9841			1.5	38.1	Universal Head		0.3	0.1



Universal Switch Stick



FRP Splices with Button

## FIBERGLASS HOT SWITCH STICKS

**Switch Sticks** use closed cell foam filled tubular fiberglass made in accordance with ASTM Standard F711. Both the standard head and the heavy duty prong disconnect are made of durable high strength aluminum bronze alloy.



Standard Prong



Heavy Duty Prong



Fiberglass Hot Switch Stick

Cat. No.		Dimensions: Dia. x Length						Weight ea.		
HD	Std	Prong	in. x ft.		mm x m		lbs.	kgs		
<b>ONE SECTION</b>										
9950	9933		1.25 x 4		31.7 x 1.2		2.1	1		
9951	9934		1.25 x 6		31.7 x 1.8		2.9	1.3		
9952	9935		1.25 x 8		31.7 x 2.4		3.6	1.6		
9953	9936		1.25 x 10		31.7 x 3		4.4	2		
9954	9937		1.25 x 12		31.7 x 3.6		5.1	2.3		
9955	9938		1.25 x 14		31.7 x 4.3		5.9	2.7		
9956	9939		1.5 x 8		38.1 x 2.4		5	2.3		
9957	9940		1.5 x 10		38.1 x 3		6	2.7		
9958	9941		1.5 x 12		38.1 x 3.6		7	3.2		
9959	9942		1.5 x 14		38.1 x 4.3		8.1	3.7		
9960	9943		1.5 x 16		38.1 x 4.9		9.1	4.1		
9961	9944		1.5 x 18		38.1 x 5.5		10.2	4.6		
9962	9945		1.5 x 20		38.1 x 6		11.2	5.1		
<b>TWO SECTION</b>										
			OAL Length		Top		Bottom			
			ft.	m	in. x ft.	mm x m	in. x ft.	mm x m	lbs.	kgs
4024	-		8	2.4	1.25 x 4	31.7 x 1.2	1.25 x 4	31.7 x 1.2	3.8	1.7
4025	-		10	3	1.25 x 5	31.7 x 1.5	1.25 x 5	31.7 x 1.5	4.6	2.1
4026	4016		12	3.6	1.25 x 6	31.7 x 1.8	1.25 x 6	31.7 x 1.8	5.3	2.4
-	4017		14	4.3	1.25 x 7	31.7 x 2.1	1.25 x 7	31.7 x 2.1	6.1	2.7
4028	4018		16	4.9	1.25 x 8	31.7 x 2.4	1.5 x 8	38.1 x 2.4	8	3.6
4029	-		18	5.5	1.25 x 8	31.7 x 2.4	1.5 x 10	38.1 x 3	9.5	4.3
4030	-		20	6	1.25 x 10	31.7 x 3	1.5 x 10	38.1 x 3	10.3	4.6
<b>THREE SECTION</b>										
			OAL Length		Top		Middle / Bottom			
			in.	mm	in. x ft.	mm x m	in. x ft.	mm x m	lbs.	kgs
4033	-		18	5.5	1.25 x 6	31.7 x 1.8	1.5 x 6	38.1 x 1.8	10.4	4.7
4034	4035		20	2	1.25 x 8	31.7 x 2.4	1.5 x 6	38.1 x 1.8	11.1	5
<b>HEAD ONLY</b>										
-	9864				1.25	31.7	Universal Head		0.4	0.2
9861	-				1.5	38.1	Universal Head		0.5	0.2

## UNIVERSAL SWITCH STICKS & ACCESSORIES

### Double Ended & Tie Heads



4182 Cap Splice Guard

**FRP Sleeve Splices** are fiberglass reinforced plastic with spring loaded push buttons. They sectionize long sticks for easy storage. For splice stick assemblies other than those listed in the catalog consult the factory for quotations.

**Splice Guards** reduce the damage to the end of spliced sticks when working with only the top sections.



FRP Splices with Button

Cat. No.	Dimensions		Weight ea.	
	in.	mm	lbs.	kgs
<b>FRP SLEEVE SPLICES</b>				
9898	1.25 to 1.25	31.7 to 31.7	0.4	0.2
9897	1.5 to 1.25	38.1 to 31.7	0.8	0.4
9899	1.5 to 1.5	38.1 to 38.1	0.9	0.4
<b>SPLICE GUARD CAP</b>				
4182	1.25 I.D.	31.7 I.D.	0.2	0.1

These foam filled FRP Hot Sticks are manufactured using a pultrusion process that results in a product with extremely high electrical and mechanical qualities.



4084 Rotary Prong



4088 Double Prong Head

Cat. No.		Dimensions: Dia. x Length		Weight ea.	
		in. x ft.	mm x m	lbs.	kgs
<b>DOUBLE ENDED UNIVERSAL</b>					
4230		1.25 x 6	31.7 x 1.8	3.3	1.5
4231		1.25 x 8	31.7 x 2.4	4	1.8
4232		1.25 x 10	31.7 x 3	4.8	2.2
4233		1.25 x 12	31.7 x 3.6	5.5	2.5
4234		1.25 x 14	31.7 x 4.3	6.3	2.8
<b>UNIVERSAL w/ Rotary Prong or Blade</b>					
4084	Rotary Prong	1.25 x 6	31.7 x 1.8	3.8	1.7
4085	Rotary Prong	1.25 x 8	31.7 x 2.4	4.5	2
<b>UNIVERSAL w/ Double Prong</b>					
4088		1.25 x 6	31.7 x 1.8	3.8	1.7
4089		1.25 x 8	31.7 x 2.4	4.5	2



Double Ended Universal Switch Stick

## RESCUE HOOK, STATIC DISCHARGE STICK

**Salisbury Insulated Rescue Hook** is an invaluable tool for any workplace used to withdraw an injured worker out of a hazardous area. Confined spaces, in vaults, or just near electrical cabinets and switch gear are some of the places where this tool is a must. Featuring a foam filled, fiberglass reinforced handle for superior electrical insulation and a coated heat treated body hook with an 18” opening. The stick is available in the standard lengths of 6 and 8-foot lengths. Other lengths are available as a special order. Contact us with your requirements.

**The Static Discharge Stick** is designed to safely remove the static charge after de-energizing. This tool is pre-assembled and includes a copper “U” hook, 4’ closed cell foam filled tubular fiberglass stick and 6’ of copper grounding cable attached to a Salisbury 1814 bronze flat jaw serrated grade 3 clamp. Also available in a 1’ length stick.



Insulated Rescue Hook



Static Discharge Stick  
w/ Universal Attachment



Static Discharge Stick

Cat. No.	Dimensions		Weight ea.	
	in.	mm	lbs.	kgs
<b>INSULATED RESCUE HOOK</b>				
24400	Rescue Hook 3' (0.9 m) length		3.4	(1.5)
24401	Rescue Hook 6' (1.8 m) length		4.5	(2)
24403	Rescue Hook 8' (2.4 m) length		5.5	(2.5)
<b>STATIC DISCHARGE STICK</b>				
20817	Static Discharge Stick 4' (1.2m) length		8	(3.6)
22629	Static Discharge Stick w/ Universal Attachment 1' (0.3m) length		.38	(0.17)

## STORAGE FOR HOT STICKS & TOOLS

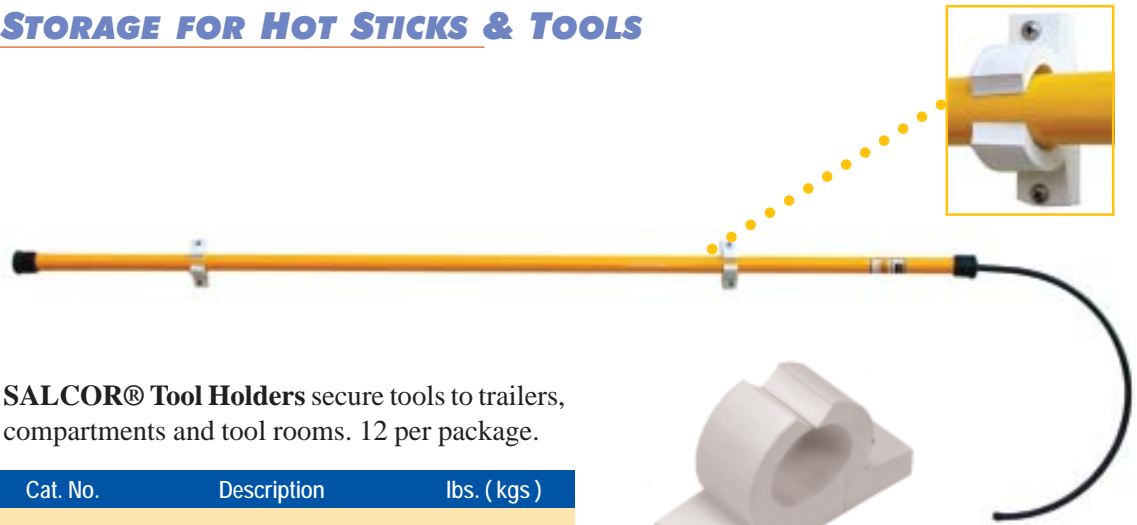

**SALCOR® Tool Holders** secure tools to trailers, compartments and tool rooms. 12 per package.

Cat. No.	Description	lbs. (kgs)
1192	1.25 (32mm) I.D. Tool Holder	3.5 (1.6)

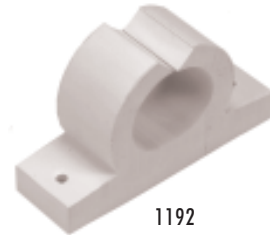

1192

### Tubular PVC Storage Containers

provide weather tight storage. Kit includes two mounting brackets and four steel bolts with each 6" (152mm) I.D. or 4.1" (104mm) tube. Sized for tools 12" (305mm) shorter than tube. Four mounting bolts 3/8" x 1.5" (9.5 x 38mm) are supplied with each container.

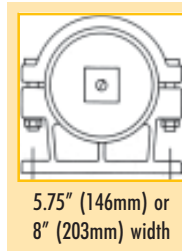

5.75" (146mm) or  
8" (203mm) width

Kit may be ordered without tubing, or with mounting brackets only.

Cat. No.	Description/Dimensions in. (mm)	lbs. (kgs)
9822	Kit for 6" (152) I.D. 6.6" (168) O.D. tube	8 (3.5)
9823	Kit for 4.1" (104) I.D. 4.5" (114) O.D. tube	6 (2.7)



4155

**Hot Stick Bags** are constructed of heavy vinyl with double stitched seams. Flaps snap closed. 6" (152mm) wide and designed to hold sticks up to 4" (102mm) shorter than bag length shown on chart.



Hot Stick Bag

Cat. No.	Feet	Length meters	Weight ea. lbs. (kgs)
<b>HOT STICK BAGS</b>			
4297	5	1.5	.7 (.3)
4298	6	1.8	.8 (.3)
4299	6' 4"	1.9	.9 (.4)
4300	7	2	1 (.4)
4301	8' 4"	2.5	1.1 (.5)
4302	9	2.7	1.2 (.5)
4303	10' 4"	3	1.4 (.6)
<b>4" I.D. TUBULAR PVC STORAGE KIT</b>			
4155	7	2.13	17 (7.7)
4156	9	2.74	20 (9)
<b>6" I.D. TUBULAR PVC STORAGE KIT</b>			
4167	6	1.82	20 (9)
4168	7	2.13	22 (10)
4169	9	2.74	26 (11.7)

## UNIVERSAL FITTINGS

*Universal Fittings, constructed of bronze or aluminum, can be installed on universal sticks or clamp sticks by using the 2500 shotgun adapter.*



2500 Shotgun Adapter  
.4 lbs (.2 kgs)



4236 Tree / Wire Hook  
.36 lbs (.2kgs)



9878 Pig Tail Disconnect  
.4 lbs (.2 kgs)



9838 Chuck Blank  
Inside Depth: 1/2" x 1 1/2" ( 13 x 38mm )  
.4 lbs (.2 kgs)



9971 Light Duty Cutout Prong  
.4 lbs (.2 kgs)



9969 Heavy Duty Disconnect Head  
.6 lbs (.3 kgs)



9970 Prong Disconnect  
.4 lbs (.2 kgs)



4099 Rotary Prong Tie Head  
.6 lbs (.27 kgs)



4100 Rotary Blade Tie Head  
.7 lbs (.3 kgs)



9839 Pointed Disconnect  
.4 lbs (.2 kgs)



4101 Double Prong Tie Head  
.5 lbs (.22 kgs)



4102 Fixed Blade Tie Head  
.5 lbs (.22 kgs)



## UNIVERSAL FITTINGS



4108 Tubular Line Cleaner  
1.3 lbs (.6 kgs)  
4109 Replacement Brush  
.5 lbs (.22 kgs)



4111 "V" Line Cleaner  
1.3 lbs (.6 kgs)  
4113 Replacement Brushes  
Carton of ten  
3 lbs (1.4 kgs)



4106 Curved Blade Skinning Knife  
.4 lbs (.2 kgs)  
4107 Replacement Blade  
.1 lbs (.05 kgs)



4105 Tree Pruner  
Mounted on 12' (3.6m) fiberglass pole,  
complete with 25' (7.62m) of line  
.4 lbs (.2 kgs)



4103 Handle for pruning saw  
.5 lbs (.22 kgs)



4104 Pruning Saw w/ 18"(457mm) blade  
.5 lbs (.22 kgs)



9834 Clamp Stick Head  
1.4 lbs (.6 kgs)



UST Universal System Tool  
Blanket Pin  
1 lb. (.45 kgs)



4114 Flex Head Socket Wrench  
1.2 lbs (.5 kgs)



4115 Ratchet Wrench  
1/2" (12.7 mm) sq. drive  
.5 lbs (.22 kgs)

## HYDRAULIC CABLE SPIKE

The **Hydraulic Cable Spike** is designed to verify underground cable, up to 1000MCM, is de-energized before cutting, repairing, splicing or replacing.

The cable spike, a solid brass body with a stainless steel piercing tip, is fitted to hydraulic compression tools so that the cable can be accurately spiked from a safe distance. An anodized aluminum insert is included to position the cable precisely.



**Improves Control,  
Accuracy and Safety  
Saves Time  
Remote Controlled**

**WARNING: ELECTRIC  
SHOCK HAZARD**  
This tool is not insulated. Use only certified, non-conductive hoses and proper personal protective equipment when using this unit. Failure to do so could result in severe injury or death.

**Adapter fits the following tools:**

Huskie EP610H  
Burndy Y46  
Brock 13-H.

Cat. No.	Cable Length ft ( m )	Description	Weight ea. lbs. ( kgs )
24320	6 ( 1.8 )	Spiking Tool & Grounding Assembly: Cable Spiking Tool & Insert	9.5 ( 4.3 )
24321	8 ( 2.4 )	4388 C Clamp 2139 4/0 Cu Cable	11.2 ( 5.1 )
24322	10 ( 3 )	2025 4/0 Cu Ferrules (Pair) 616 Bag US Patent # 544 7450	12.9 ( 5.86 )
RPT1		Replacement Piercing Tip	1 oz ( 28 g )

# FIBERGLASS HOT CLAMPSTICKS REPAIR PARTS LIST

## External Rod

Ref. No.	Cat. No.	Description
1	20178	Guide Assembly
2	20260	Roll Pin .125" Dia. x .5" Lg. ( 3.2 x 13mm )
3	20174	Ferrule
4*	20265-1	Operating Rod
5*	20381	Operating Rod Guide
6	20250	Handguard Sleeve
7	20114	Hot Stick Blank 1.25" Dia. (32mm)
8	20262	Roll Pin .125 Dia. x .56 Lg. ( 3.2 x 14mm )
9	20251	Operating Rod Connector
10	20258	Hex Socket Set Screw .375-16 x 1.25
11	20257	Flat Head Screw 10-32 x 1.125 Lg. ( 254-813 x 29 )
12	20253	Adjustment Block
13	20254	Compression Spring
14	20139	Button
15	20263	Roll Pin .125 Dia. x .75 Lg. ( 3.2 x 19 )
16	20445	10-32 Hex Jam Nut
17	20443	Hex Head Machine Screw 10-32 x 1.25
18	20140	Trigger
19	20255	Torsion Spring
20	20141	Handgrip
21	20142	Rack for Handgrip
22	20257	Flat Head Screw 10-32 x 1.125 Lg. ( 254-813 x 29 )
23	20252	Handgrip Sleeve
24	1959	End Cap
25	20176	Jaw Hook
26	20332	Roll Pin .25 Dia. x .47 Lg. ( 6 x 12 )
27	20470	Hook Spring
28	20177	Hook Holder

Assembly No.	Description	Consist of Parts
4317	Hook Assembly	28, 29, 30, 31

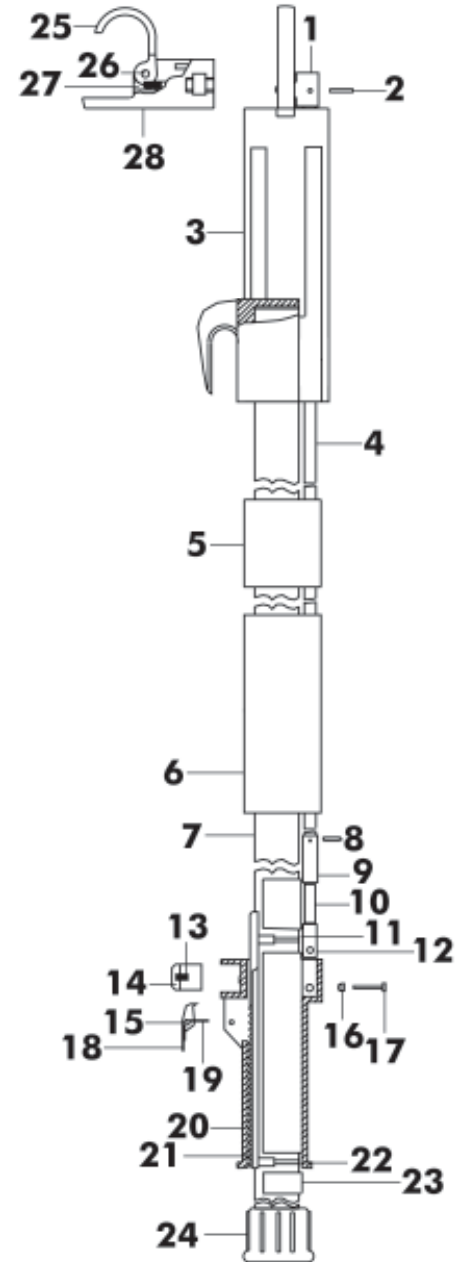

# INSULATORS

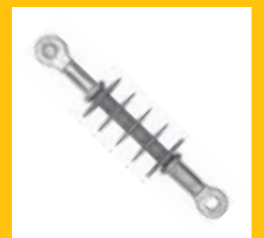
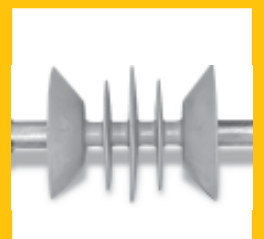

**Salisbury Composite Insulators** combine the technologies of fiberglass reinforced rod, metal fittings and our extensive knowledge of elastomeric insulation to produce a high quality composite insulator. Since 1980 thousands of Salisbury Insulators have been installed by utilities worldwide in a variety of environments. Continued outstanding performance is proof of their superior quality and design.

**Design:** Unibody Design insulators are one-piece injection molded directly to the rod and sealed to the end fittings with a bead of silicone to give the insulator high dielectric strength and protect it from all environmental conditions. This design is used for standard distribution dead end/suspension insulators.

**Fiberglass Rod:** A high quality, corrosion resistant, fiberglass reinforced rod is the core of every insulator with ultimate mechanical strength at least twice the maximum working load.

**End Fittings:** Standard distribution dead/end suspension units are supplied with clevis and tongue fittings meeting ANSI C29-2 specifications. Ball, socket, and eye fittings are also available. All are made of hot dipped galvanized high strength carbon steel (stainless steel available upon request) and have an ultimate tensile strength rating of 15,000 pounds. All end fittings on dead/end suspension insulators are attached by compression. *Every* insulator is proof tested to verify the crimp.

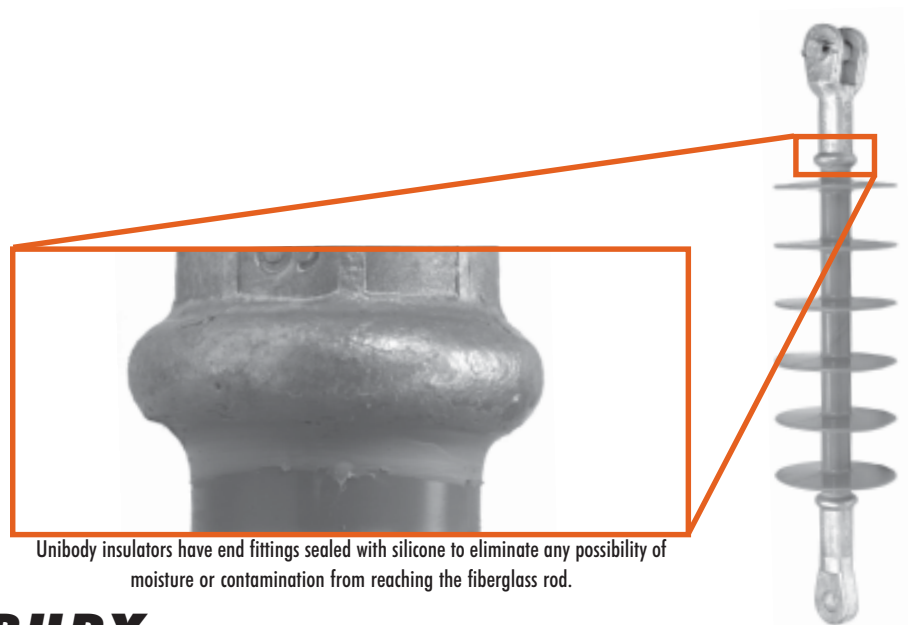

Unibody insulators have end fittings sealed with silicone to eliminate any possibility of moisture or contamination from reaching the fiberglass rod.

# SI SERIES SILICONE INSULATOR

15kV to 46kV

Dead End/Suspension, Tongue & Clevis

The SI Series of Silicone Insulators features a silicone formulated weathershed material. Salisbury combined the excellent hydrophobic and electrical qualities of silicone with an optimum weathershed design and corrosion resistant fiberglass rod to produce a state-of-the-art insulator which meets or exceeds industry requirements. The insulators were tested in accordance with ANSI C29 and IEC1109. End fittings are hot dipped galvanized high strength carbon steel, providing a 15,000 pound ultimate tensile strength. 100% proof testing ensures trouble-free installation.

RUS Accepted.



Unibody insulators have end fittings sealed with silicone to eliminate any possibility of moisture or contamination from reaching the fiberglass rod.

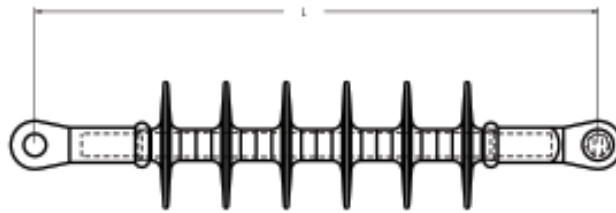

		9501U-SI	9502U-SI	9503U-SI
Class		DS-15	DS-28	DS-35, DS-46
No. of Weathersheds		4	6	8
Length—in (m)		13.5 (.34)	17.5 (.45)	21.3 (.54)
Dia. of Weathersheds—in (mm)		3.8 (97)	3.8 (97)	3.8 (97)
Leakage Distance—in (m)		17.1 (.44)	26 (.66)	35.1 (.89)
Electrical	Critical Impulse	173	217	258
Ratings	Dry, 60 Hz	97	145	340
kV	Wet, 60Hz	67	115	168
Radio	Test--kV Ground	15	25	25
Influence	Max RIV—1000kHz μV	<10	<10	<10
Typ. Appl—kV, Ø-Ø		15	27	35
Net Weight ea.—lbs. (kgs)		2.6 (1.20)	3.1 (1.39)	3.5 (1.57)

## THE 9502L-EP SILICONE INSULATOR

27kV

The 9502L-EP Silicone Insulator combines two essential characteristics:

**PERFORMANCE** - The 9502L-EP is the only composite insulator manufactured as a replacement for two 10" (254mm) porcelain disks. Installation is limited to horizontal dead-end applications only.

**INNOVATION** - Unlike any other insulator on the market, the unique shed design of the 9502L-EP minimizes the material content without compromising electrical or dimensional requirements.

End fittings are hot dipped galvanized high strength carbon steel.

Must be used as a dead end insulator only.

**RUS Accepted.**

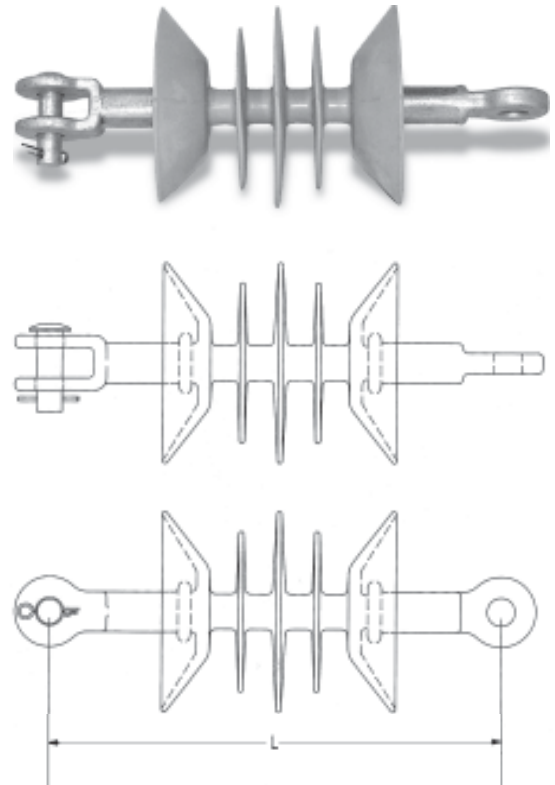

		9502L-EP
No. of Weathersheds		5
Length—in (m)		11.5 (.29)
Dia. of Weathersheds—in (mm)		5 (127)
Leakage Distance—in (m)		22 (.56)
Electrical	Critical Impulse	189
Ratings	Dry, 60 Hz	116
kV	Wet, 60 Hz	92
Radio	Test--kV Ground	20
Influence	Max RIV--1000Hz $\mu$ V	1
Typ. Appl--kV, $\emptyset$ - $\emptyset$		27
Ultimate Strength--SML-- lbs / kN		15000 / 70
Net Weight ea. --lbs ( kgs )		2.8 ( 1.3 )

## ACCESSORIES





## CANVAS BUCKETS AND BAGS



**Salisbury Tool Buckets** are constructed of extra-heavy-duty canvas duck and reinforced with a one-piece formed leather bottom with a 3" (76mm) cuff for rugged service and long life. The standard tool buckets, 30 and 40, are both collapsible for easy storage and feature a poly braid rope handle. The oval tool bucket, 50, designed to attach to aerial baskets, features 6 inner tool pockets and two plastic hanging hooks.

**Salisbury Tool Bags** are useful for carrying and storing all sorts of equipment and tools. Constructed for long life and rugged service from one piece of #8 white canvas fastened to a steel frame. The synthetic leather bottom is cemented and double stitched to the bag and protected with steel studs and a reinforcing 3.5" (89mm) cuff. Handles and straps are made of top grain harness leather.

**Line Hose and Blanket Bags** are convenient for raising and lowering bulky items up and down a pole, as well as for storage. Constructed of #6 duck, sewn with nylon thread, and reinforced with a weatherproof leather with a 3" (76mm) cuff for added strength. Features a cyclac top ring to hold the bag open and a strong 1/2" (12.7mm) poly braid rope handle, reinforced with leather. 7" (178mm) diameter bags are used for conventional style line hose, while the 12" (305mm) diameter bags were designed for Class 4 extended lip line hose.

Cat. No.	Dimensions in. ( mm )	Weight ea. lbs. ( kgs )
<b>STANDARD TOOL BUCKETS</b>		
30*	12 x 16 ( 305 x 406 )	3.2 ( 1.45 )
40*	8 x 14 ( 203 x 356 )	2 ( .91 )
<b>OVAL TOOL BUCKET</b>		
50*	7x14x10 ( 1715x356x254 )	2.5 ( 1.14 )
PH55	yellow vinyl hooks for #50	.5 ( .23 )
<b>STANDARD Tool Bags- 5.5" (140mm) wide</b>		
616	16 x 13.5 ( 406 x 343 )	3.3 ( 1.5 )
618	18 x 15.5 ( 457 x 394 )	3.8 ( 1.73 )
620	20 x 15.5 ( 508 x 394 )	4.2 ( 1.91 )
622	22 x 15.5 ( 559 x 394 )	4.3 ( 1.95 )
624	24 x 15.5 ( 610 x 394 )	4.5 ( 2.04 )
<b>EXTRA WIDE Tool Bags-9.5" (241mm) wide</b>		
2419B	24 x 19 ( 610 x 483 )	4.1 ( 1.86 )
<b>LINE HOSE BAGS</b>		
48*	7 x 48 ( 178 x 1219 )	2.8 ( 1.27 )
60*	7 x 60 ( 178 x 1524 )	3.0 ( 1.36 )
66*	7 x 66 ( 178 x 1676 )	3.3 ( 1.5 )
72*	7 x 72 ( 178 x 1829 )	3.5 ( 1.59 )
1248*	12 x 48 ( 305 x 1219 )	3.8 ( 1.73 )
1266*	12 x 66 ( 305 x 1676 )	5.3 ( 2.41 )
<b>BLANKET BAG</b>		
1230	12 x 30 ( 305 x 762 )	3.2 ( 1.45 )

\*add suffix "S" if optional iron swivel snap is desired

**SALISBURY**

Setting industry standards since 1855. 7520 N Long Ave Skokie IL 60077 Toll Free 877.406.4501 Fax 847.679.2401

X-3

**Compound Pots** are made of hard rubber that is nonconductive and breakage resistant. The applicator brush and compound are held in one unit that can be hung from aerial devices or fit into cross arm holes. Offered in single and double compartment styles.

**Cable Bandages** provide temporary insulation for bare conductors and splices. A single thickness of the orange SALCOR® Bandage can withstand 15kV on puncture test. The black neoprene bandage is intended to provide fast and complete temporary cover for cable splicers.

**Insulating Saddles** are ideal for temporary or emergency line work such as stringing light conductors over short spans. The large 3” (76mm) upper saddle opening will hold bare or insulated conductors in either an upright or inverted position. Molded of hard rubber and furnished with two nylon holding pins supplied with steel loops for easy hot-stick application. A 12” (305mm) orange plastic shoe is affixed to the crossarm opening to help prevent flashover during inclement weather. Designed to fit crossarms with dimensions up to 3.75” x 5” (95mm x 127 mm).



Cat. No.	Description	in. ( mm )	Weight ea. lbs. ( kgs )
<b>COMPOUND POT SINGLE COMPARTMENT</b>			
PJB1	1pt. w/ bristle brush	4.5" x 3.5" ( 114 x 89 )	1.5 ( .681 )
PJB2	1 pt. w/ wire brush	4.5" x 3.5 ( 114 x 114 )	1.5 ( .681 )
<b>CABLE BANDAGES</b>			
440S	Orange SALCOR	4' ( 1.2m ) w/ strap	1 ( .5 )
414PG	Pure Gum Rubber	14' ( 4.3m ) w/o strap	1 ( .5 )
414BN	Black Neoprene	14' ( 4.3m ) w/o strap	1 ( .5 )
<b>INSULATING SADDLE</b>			
IS10		11.25 x 4.75 ( 286 x 121 )	4 ( 1.8 )
ISP	Replacement Pin		.25 ( .1 )

## SPECIAL EQUIPMENT

**BELT HOOK/BREAK-AWAY** is nonconductive yellow nylon hand-line belt hook that will bend or break if suddenly pulled.



H7

**Climber Guards** are manufactured by the dipping process using the same formulation of rubber as our lineman's insulating gloves and sleeves. Climber Guards are furnished un-slit to accommodate any length, regular or adjustable climbers. Sold in pairs only.



21187



Cat. No.	Description / Dimensions in. ( mm )	Weight ea. lbs. ( kgs )
<b>BELT HOOK / BREAK-AWAY</b>		
<b>H7</b>	Break-Away Belt Hook	1 oz. ( .03 )
<b>CLIMBER GUARDS</b>		
<b>21187</b>	sold in pairs	.5 ( .23 )

## **ARC FLASH PROTECTION &**

## **SALISBURY INSULATED PRODUCTS (S.I.P.) INSULATED TOOLS**

**Salisbury offers an entire line of Arc Flash Protective Clothing and Equipment ranging from 8 cal/cm<sup>2</sup> to 100 cal/cm<sup>2</sup>.**

Ask your local Salisbury representative for a copy of our Arc Flash Protection Catalog or download it from our website at [whsalisbury.com](http://whsalisbury.com).

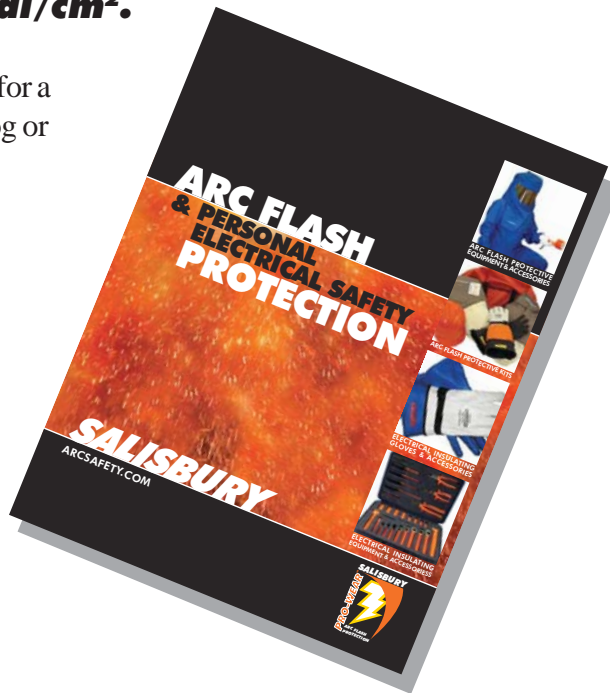

**Salisbury also offers Salisbury Insulated Products (S.I.P.) PRO-TOOL™ Insulated Tools and Tool Kits.**

PRO-TOOLS are all tested to 10,000 VAC for use up to 1,000 VAC. These tools meet or exceed ASTM F1505-01 and IEC 900 Standards for Insulated Hand Tools and will help you to be compliant with OSHA 1910.333 (c)(2), and NFPA 70E 2000.

Ask your local Salisbury representative for a copy of our S.I.P. PRO-TOOL Catalog or download it from our website at [whsalisbury.com](http://whsalisbury.com).

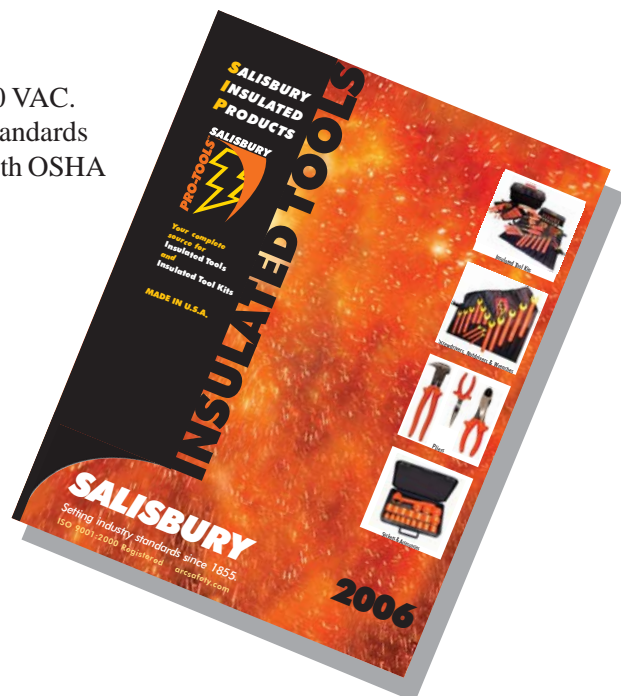



## North Safety Products

2000 Plainfield Pike Cranston, RI 02921 ph:(800)430-4110 fax:(800)572-6364 www.northsafety.com

## North Safety Products Ltd.

10550 Parkway Blvd. Anjou (Quebec) H1J 2K4 ph:(514)351-7233 fax:(514)355-7233 1-888-212-7233 www.northsafety.ca

## North Safety Products B.V.

Noordmonsterweg 1 4332 SC Middelburg The Netherlands ph: +31 (0) 118 656400 fax: +31 (0) 118 627535 www.northsafety.nl

### HEAD PROTECTION

Hardhats  
Bumpcaps  
Winter Liners

### EYE & FACE PROTECTION

Safety Glasses  
Goggles  
Faceshields

### HEARING PROTECTION

Disposable and  
Reusable Earplugs  
Earmuffs

### RESPIRATORY PROTECTION

Air-Purifying  
Airline  
SCBA

### HAND PROTECTION

General Purpose  
Chemical Resistant

### PROTECTIVE CLOTHING

General/Fire Retardant  
Rainwear/Chemical Suits  
Sleeves/Aprons

### TRAFFIC SAFETY PRODUCTS

Vests/Clothing  
Cones  
Barricade Tape  
Signs

### FIRST AID PRODUCTS

Kits/Cabinets/Refills  
BBP/CPR Products  
Dermatologicals  
Eyewash Stations

### FALL PROTECTION

Belts/Harnesses/Lanyards  
Retractable Lifelines  
Confined Space Systems  
Engineered Systems

### CONTROLLED ENVIRONMENT

Cleanroom Gloves  
Drybox Gloves  
Finger Cots

### SAFETY SIGNS

OSHA/CSA/Photo-luminescent  
Pipe Markers  
Numerals/Letters/Barricade Tape

### PROTECTIVE FOOTWEAR

Industrial/Construction  
Chemical and  
Slip Resistant

### ELECTRICAL SAFETY PRODUCTS

Electrical Gloves  
Jumper Cables  
Power Line Hose

### LOCKOUTS/TAGOUTS

Valve Lockouts and Tags  
Electrical Lockouts and Tags

### CONSUMER PRODUCTS

Point of Purchase Packaging



## Norcross Safety Products

1136 Second Street Rock Island, IL 61201 ph:(800)777-9021 fax:(309)786-6923 (800)267-6809

### RUBBER PROTECTIVE FOOTWEAR

Ranger™ Mining & Heavy Industrial  
Servus™ General Industrial & Outdoor Work

### MOLDED PROTECTIVE FOOTWEAR

Servus Processing Petrochemical and HazMat  
Servus General Industrial & Outdoor Work

### DIPPED NEOPRENE PROTECTIVE FOOTWEAR

Servus Processing and Petrochemical

### SERVICE SLIP RESISTANT FOOTWEAR ACCESSORIES

Insoles  
Insulating Liners  
Repair Kits

### COLD WEATHER PAC BOOTS

Servus Steel Toe Pacs  
Ranger Outdoor Pacs



## Total Fire Group

#1 Innovation Court Dayton, OH 45414 ph:(800)688-6148 fax:(937)264-2677 www.totalfiregroup.com

### MORNING PRIDE® PROTECTIVE CLOTHING, HELMETS, GLOVES, HOODS AND AUXILIARIES

RANGER™ FIREFIGHTER FOOTWEAR  
Shoe Fit  
Combat LB

### SERVUS® FIREFIGHTER FOOTWEAR

Fighting Weight Boot  
Unishield Technology Design  
Protekshin Shock Absorbing System  
Accu Fit Sizing

### WARRINGTON PRO® FIREFIGHTER FOOTWEAR

Metro Style Leather Firefighting Boots  
Station Shoes

### NORTH FIRE SERVICE PRODUCTS

Heat Stress Rehab Packs  
Kevlar Knit Gloves  
Safety Goggles  
Safety Spectacles DeciGuard AB® Earplugs with Microban®  
Bump Caps  
Harnesses  
Tripods  
Winches  
Self-Retracting Lifelines  
Technical Rescue Systems

### SALISBURY FIRE SERVICE PRODUCTS

Hot Switch Sticks  
Hot Clamp Sticks  
Rubber Electrical Insulating Gloves  
Leather Protectors  
Storage Bags



ISO 9001:2000 Registered

**SALISBURY**  
Setting industry standards since 1855.

**W.H. SALISBURY & Co.**

7520 North Long Avenue  
Skokie IL 60077-3226 USA  
toll free ph. 877.406.4501  
toll free fax 866.824.4922  
847.679.6700

**whsalisbury.com**

**AUTHORIZED DISTRIBUTOR**